

Common Terminal Block (rising clamp type)

Features

- Rising clamp type connection for simple and easy connection
- No jumper bars required due to built-in common PCB
- For use as power supply expansion terminals
- Slim and compact design with 5mm terminal pitch
- 2 mounting methods (DIN rail, screw mount)

 Please read "Safety Considerations" in instruction manual before using.

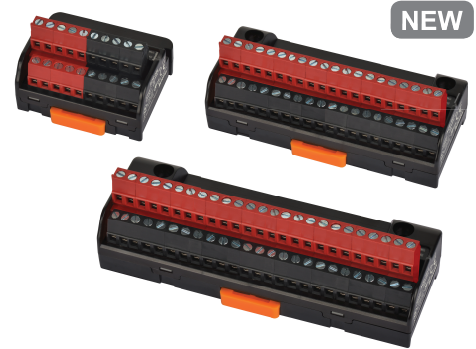

Ordering Information

Model	Item	Terminal type	The number of terminal	Common type
ACR-20L	Common terminal block	Rising clamp	20	Left-Right common
ACR-20T				Up-Down common
ACR-40L			40	Left-Right common
ACR-40T				Up-Down common
ACR-50L			50	Left-Right common
ACR-50T				Up-Down common

Crimp Terminal Specifications

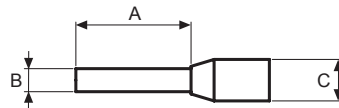

(unit: mm)

	A	B	C	Applicable wire
End Sleeve (ferrule terminal) crimp terminal	10 to 12.0	≤ 2.0	≤ 4.1	AWG22-16 (0.30 to 1.25mm ²)

※ Use the UL certified crimp terminal.

Specifications

Model	ACR-20L	ACR-40L	ACR-50L	ACR-20T	ACR-40T	ACR-50T
Rated voltage ^{※1}	250VDC=, 250VAC~ 50/60Hz					
Rated current	≤10A					
Common type	Left +COM / Right -COM			Top +COM / Bottom -COM		
Terminal type	Rising clamp					
The number of terminal	20	40	50	20	40	50
Terminal pitch	5.0mm					
Tightening torque	0.4 to 0.6N·m					
Applicable wires	Solid wire: Ø0.6 to Ø1.25mm (60°C only)					
	Stranded wire: UL: AWG22-16 (0.30 to 1.25mm ²) (60°C only)					
Stripped wire length	8 to 10mm					
Insulation resistance	≥1,000MΩ (at 500VDC megger)					
Dielectric strength	3,000VAC 50/60Hz for 1 minute (between open terminals)					
Vibration	Mechanical: 0.75mm amplitude at frequency of 10 to 55Hz (for 1 min) in each X, Y, Z direction for 2 hours					
	Malfunction: 0.75mm amplitude at frequency of 10 to 55Hz (for 1 min) in each X, Y, Z direction for 10 minutes					
Shock	Mechanical: 1,000m/s ² (approx. 100G) in each X, Y, Z direction for 3 times					
	Malfunction: 100m/s ² (approx. 10G) in each X, Y, Z direction for 3 times					
Environment	Ambient temp.: -15 to 55°C, storage: -25 to 65°C					
	Ambient humi.: 35 to 85%RH, storage: 35 to 85%RH					
Material	Terminal: polyamide 66, conductive plate: copper, tin plated, case: polycarbonate, base: polycarbonate					
Protection structure	IP20 (IEC standard)					
Approval						
Weight ^{※2}	Approx. 84g (approx. 55g)	Approx. 172g (approx. 105g)	Approx. 197g (approx. 130g)	Approx. 84g (approx. 55g)	Approx. 172g (approx. 105g)	Approx. 197g (approx. 130g)

※1: UL approved rated voltage of ACR- L Series is 30VDC, 30VAC other than at fi eld wiring.

※2: The weight includes packaging. The weight in parenthesis is for unit only.

※Environment resistance is rated at no freezing or condensation.

Common Terminal Block

(unit: mm)

Dimensions

ACR-20L(T)

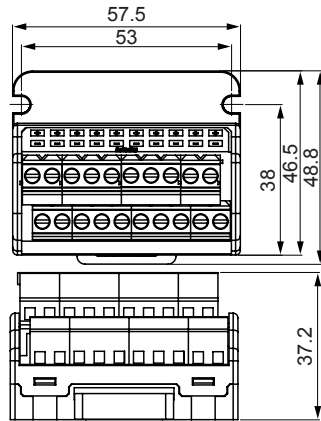

ACR-40L(T) / ACR-50L(T)

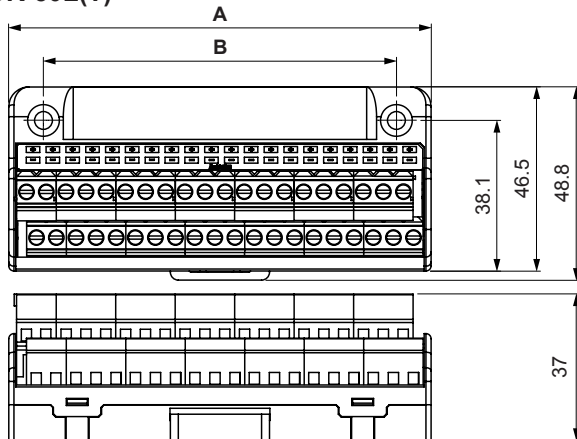

model	A	B
ACR-40L(T)	106.5	89
ACR-50L(T)	131.5	102

(unit: mm)

I/O Terminal Blocks

Interface Terminal Blocks

Common Terminal Blocks

Sensor Connector Terminal Blocks

Relay Terminal Blocks

I/O Cables

Remote I/O

Others

ACS Series

ACL Series

ACR Series

Connections

ACR-20L

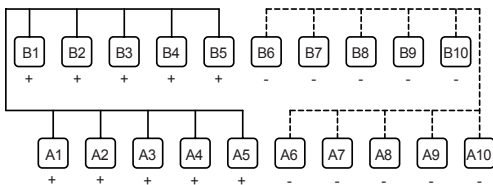

ACR-20T

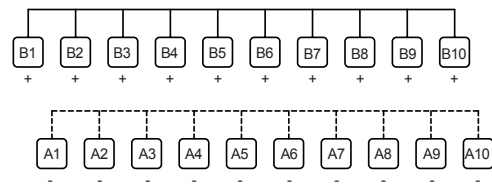

ACR-40L

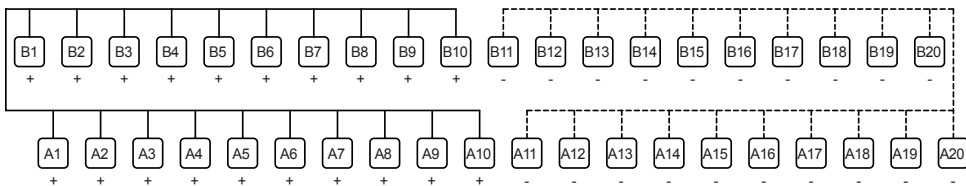

ACR-50L

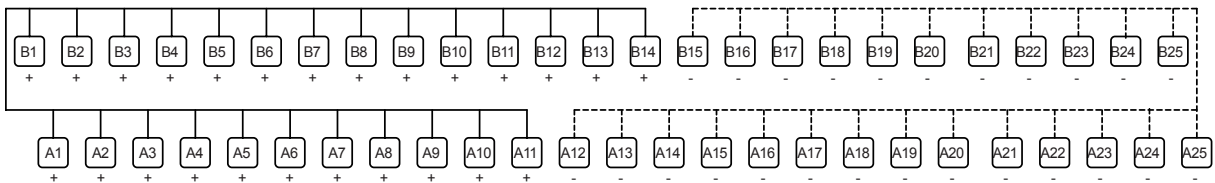

ACR-40T / ACR-50T

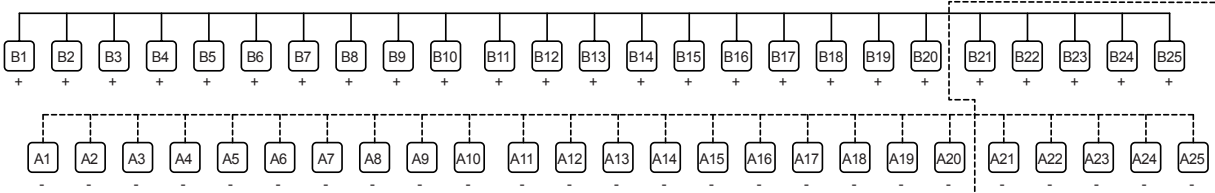

※Dot line part is only for ACR-50T model.

■ Installation

○ Mounting and Removing from DIN rail

● Mounting

- 1) Pull the rail lock towards direction ①.
- 2) Attach the DIN rail connection part onto the DIN rail.
- 3) Push the unit towards direction ②, then push the rail lock into to lock into position.

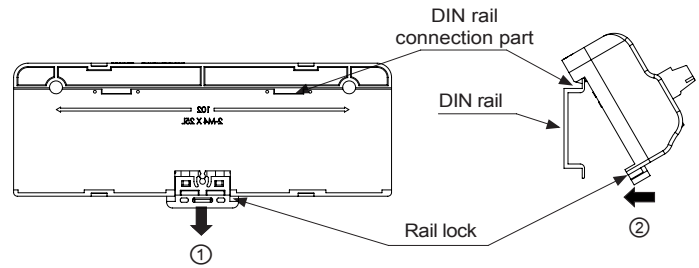

● Removal

- 1) Insert a screwdriver into the rail lock hole and pull it towards direction ③.
- 2) Remove the unit by pulling the unit towards direction ④.

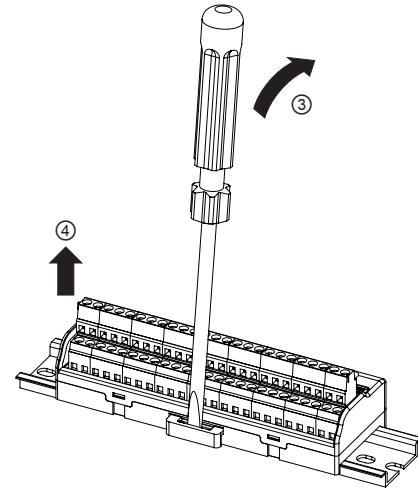

○ Mounting with screws

- 1) The unit can be mounted on panels using the mounting holes next to the Hirose connector.
- 2) M4×25mm spring washer screws are recommended for installation. When using flat washers, use Ø8mm diameter washers. The tightening torque should be from 0.7 to 1.0N·m.

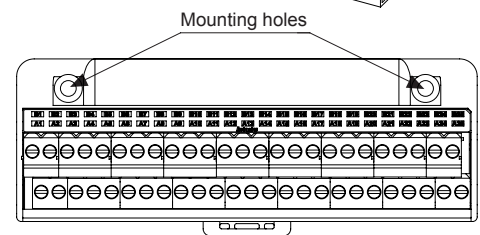

■ Connecting Crimp Terminals

○ Connecting and removing end sleeve (ferrule terminal) crimp terminal at rising clamp type terminal block

● Connecting

- 1) Insert a flat-head screw driver into the hole above the terminal. Rotate the screw in direction ① (CCW).
- 2) Push the end sleeve (ferrule) crimp terminal towards direction ②.
- 3) Insert a flat-head screw driver into the hole above the terminal. Rotate the screw in direction ③ (CW).
The tightening torque should be between 0.4 to 0.6N·m.

● Removing

- 1) Insert a flat-head screw driver into the hole above the terminal. Rotate the screw in direction ① (CCW).
- 2) Remove the end sleeve (ferrule crimp terminal) towards direction ④.

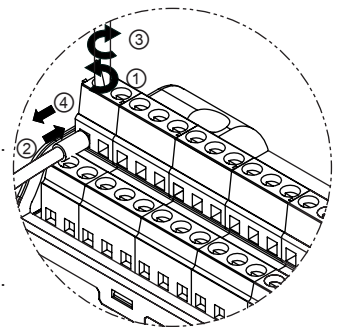

■ Cautions during Use

1. Follow instructions in 'Cautions during Use'. Otherwise, it may cause unexpected accidents.
2. Keep away from high voltage lines or power lines to prevent inductive noise.
In case installing power line and input signal line closely, use line filter or varistor at power line and shielded wire at input signal line. Do not use near the equipment which generates strong magnetic force or high frequency noise.
3. This unit may be used in the following environments.
 - ① Indoors (in the environment condition rated in 'Specifications')
 - ② Altitude max. 2,000m
 - ③ Pollution degree 2
 - ④ Installation category II

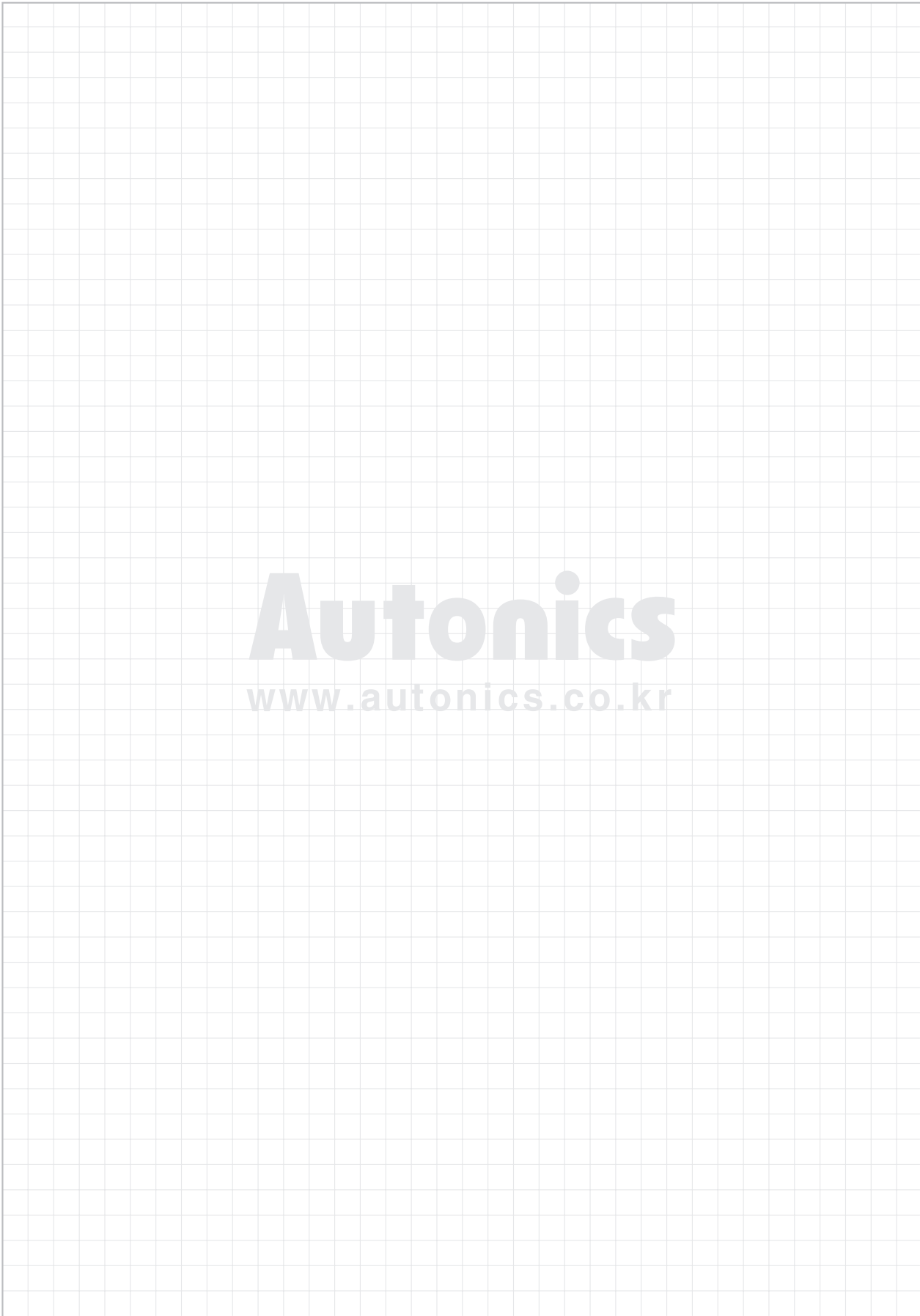

I/O Terminal Blocks

Interface Terminal Blocks

Common Terminal Blocks

Sensor Connector Terminal Blocks

Relay Terminal Blocks

I/O Cables

Remote I/O

Others

ACS Series

ACL Series

ACR Series