

AiS-D Series

2-Phase Closed-Loop Stepper Motor Driver

NEW

■ Features

- Realized the closed loop with competitive price compared to the servo motor system and rapid response which is advantageous for the short distance continuous operation
- Able to implement Low frequency operation in low speed area and high torque in high speed area
- Easy to use as much as unskilled people can use with tuning unnecessary method (Gain setting with the switch)
- Applicable to the precision equipment such as optical inspection equipment with the features of maintaining torque in stop and having no micro vibration (hunting)
- Various resolutions
: 500, 1000, 1600, 2000, 3200, 3600, 5000, 6400, 7200, 10000 (10 steps)
- Various alarms out
: overcurrent, over speed, motor connection error, encoder connection error, and etc., overall 12 types
- Frame size 42mm, 56mm, 60mm supported



⚠ Please read "Safety Considerations" in operation manual before using.



■ Applications

- Filed requiring preciseness such as semiconductor equipment, 3D printer, Optical inspection equipment, chip mounter, cartesian robot, conveying equipment, and alignment stage.

■ Ordering Information

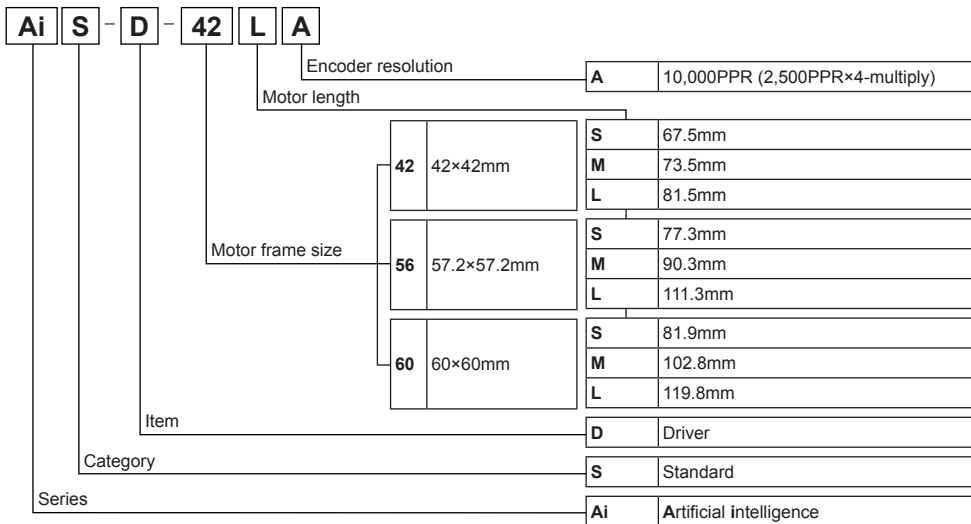

Set	Driver	Motor
AiS-42SA	AiS-D-42SA	Ai-M-42SA
AiS-42MA	AiS-D-42MA	Ai-M-42MA
AiS-42LA	AiS-D-42LA	Ai-M-42LA
AiS-56SA	AiS-D-56SA	Ai-M-56SA
AiS-56MA	AiS-D-56MA	Ai-M-56MA
AiS-56LA	AiS-D-56LA	Ai-M-56LA
AiS-60SA	AiS-D-60SA	Ai-M-60SA
AiS-60MA	AiS-D-60MA	Ai-M-60MA
AiS-60LA	AiS-D-60LA	Ai-M-60LA

2-Phase Closed-Loop Stepper Motor Driver

■ Specifications

Model	AiS-D-42SA	AiS-D-42MA	AiS-D-42LA	AiS-D-56SA	AiS-D-56MA	AiS-D-56LA	AiS-D-60SA	AiS-D-60MA	AiS-D-60LA	
Power supply	24VDC≒									
Allowable voltage range	90 to 110% of the rated voltage									
Current consumption	STOP ^{※1}	Max. 7W	Max. 7.5W	Max. 8W	Max. 9.5W	Max. 10W	Max. 11W	Max. 12W	Max. 13W	Max. 14W
	Max. during operation ^{※2}	Max. 60W			Max. 120W			Max. 240W		
Max. RUN current ^{※3}	1.7A/Phase			3.5A/Phase						
STOP current	25% or 50% of max. RUN current (set by SW4 switch)									
Rotation speed	0 to 3000rpm									
Resolution	500, 1000, 1600, 2000, 3200, 3600, 5000, 6400, 7200, 10000PPR (set by SW2 switch)									
Motor drive response	0 to F (set by SW1 switch)									
Position control gain	0 to F (set by SW3 switch)									
In-Position	0 to F (set by SW3 switch)									
Pulse input method	1-pulse or 2-pulse input method (set by SW4 switch)									
Motor rotation direction	CW, CCW (set by SW4 switch)									
Status indicator	<ul style="list-style-type: none"> ● Power/Warning indicator: green LED ● In-position indicator: yellow LED ● Alarm indicator: red LED ● Servo On/Off indicator: orange LED 									
Input signal	RUN pulse, servo On/Off, alarm reset (photocoupler input)									
Output signal	In-position, alarm output (photocoupler output), encoder signal (A, \bar{A} , B, \bar{B} , Z, \bar{Z} phase, corresponding to 26C31) (line driver output)									
Input pulse specifications	Pulse width	CW, CCW: input pulse frequency duty 50%, servo On/Off: min. 1ms, alarm reset: min. 20ms								
	Rising/Falling time	CW, CCW: max. 0.5 μ s								
	Pulse input voltage	CW, CCW - [H]: 4-8VDC≒, [L]: 0-0.5VDC Servo On/Off, alarm reset - [H]: 24VDC≒, [L]: 0-0.5VDC								
	Max. input pulse freq. ^{※4}	CW, CCW: 500kHz								
Input resistance	220 Ω (CW, CCW), 10k Ω (servo On/Off, alarm reset)									
Insulation voltage	Over 100M Ω (at 500VDC megger)									
Dielectric strength	1,000VAC 60Hz for 1 min									
Vibration	1.5mm amplitude at frequency 10 to 55Hz (for 1 min) in each X, Y, Z direction for 2 hours									
Shock	300m/s ² (approx. 30G) in each X, Y, Z direction for 3 times									
Environment	Ambient temp.	0 to 50°C, storage: -10 to 60°C								
	Ambient humi.	35 to 85%RH, storage: 10 to 90%RH								
Approval	CE									
Protection structure	IP20 (IEC standard)									
Weight ^{※5}	Approx. 400g (approx. 290g)									

※1: Based on the ambient temperature 25°C, ambient humidity 55%RH, and STOP current 50%.

※2: Max. power consumption during operation. When changing the load rapidly, instantaneous peak current may increase. The capacity of power supply should be over 1.5 to 2 times of max. power consumption.

※3: RUN current varies depending on the input RUN frequency and max. RUN current at the moment varies also.

※4: Max. input pulse frequency is max. frequency to be input and does not same as max. pull-out frequency or max. slewing frequency.

※5: The weight includes packaging. The weight in parenthesis is for unit only.

※Environment resistance is rated at no freezing or condensation.

(A) Photoelectric Sensors

(B) Fiber Optic Sensors

(C) Door/Area Sensors

(D) Proximity Sensors

(E) Pressure Sensors

(F) Rotary Encoders

(G) Connectors/ Connector Cables/ Sensor Distribution Boxes/Sockets

(H) Temperature Controllers

(I) SSRs / Power Controllers

(J) Counters

(K) Timers

(L) Panel Meters

(M) Tacho / Speed / Pulse Meters

(N) Display Units

(O) Sensor Controllers

(P) Switching Mode Power Supplies

(Q) Stepper Motors & Drivers & Controllers

(R) Graphic/ Logic Panels

(S) Field Network Devices

(T) Software

AiS-D Series

■ Dimensions

(unit: mm)

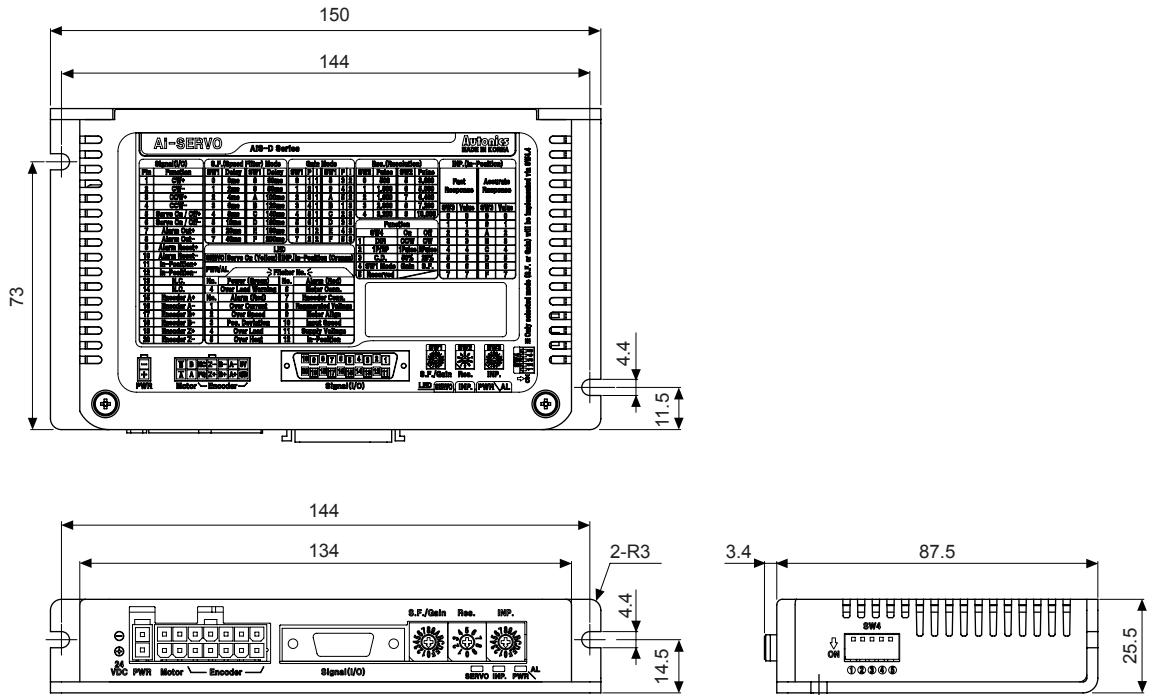

■ Driver Unit Descriptions

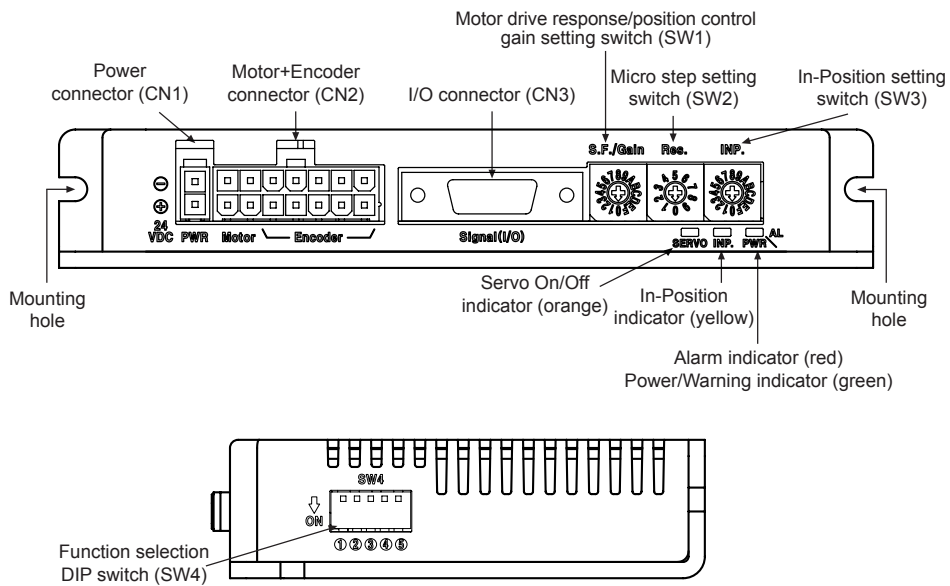

2-Phase Closed-Loop Stepper Motor Driver

■ Driver Status Indicators

Status indicator	LED color	Function	Descriptions
PWR	Green	Power indicator	Turns ON when the unit operates normally after supplying power
		Warning indicator	Flashes when over load status is maintained
AL	Red	Alarm indicator	When alarm occurs, it flashes in various ways depending on the situation. Refer to '■ Control Input/Output → ◎Output → 2. Alarm/Warning'
INP.	Yellow	In-Position indicator	Turns ON when motor is placed at command position after positioning input.
SERVO	Orange	Servo On/Off indicator	Turns ON when servo is operating, turns OFF when servo is not operating.

■ Driver Setting

◎ SW1: Motor drive response setting switch (speed filter) or position control gain setting switch

-SW1 shifts its mode between motor drive response setting or position control gain setting, depending on 4th pin in SW4 as follows.

-Modified setting values are not applied in the running status, and the values will be applied after motor stopped.

4th pin in SW4	Setting
OFF	Motor drive response
ON	Position control gain

● Motor drive response setting

-Set motor drive response for input pulse.

-Set the delay time between the position of input pulse and the position of motor to prevent load changing or disturbance with soft operation function.

※If the setting value is too high, the synchronous response by command is decreased.

Setting switch	Setting	Delay time
 S.F./Gain	0	Not used
	1	2ms
	2	4ms
	3	6ms
	4	8ms
	5	10ms
	6	20ms
	7	40ms
	8 (factory default)	60ms
	9	80ms
	A	100ms
	B	120ms
	C	140ms
	D	160ms
	E	180ms
	F	200ms

<Graph for input speed and motor response>

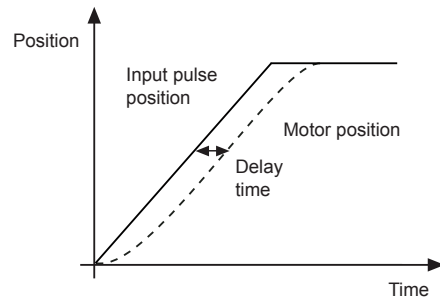

● Position control gain setting

-Position control gain decides responsiveness of motor to position command.

-Gain setting in motor stationary state, depending on load of motor, realizes rapid positioning and stabilized performance.

-P_Gain: Adjust vibration in running status.

-I_Gain: Adjust vibration in accelerating/decelerating status.

Setting switch	Setting	Gain		Setting	Gain	
		P	I		P	I
 S.F./Gain	0	1	1	8 (factory default)	3	2
	1	2	1	9	4	2
	2	3	1	A	5	2
	3	4	1	B	1	3
	4	5	1	C	2	3
	5	6	1	D	3	3
	6	1	2	E	4	3
	7	2	2	F	5	3

(A) Photoelectric Sensors

(B) Fiber Optic Sensors

(C) Door/Area Sensors

(D) Proximity Sensors

(E) Pressure Sensors

(F) Rotary Encoders

(G) Connectors/ Connector Cables/ Sensor Distribution Boxes/Sockets

(H) Temperature Controllers

(I) SSRs / Power Controllers

(J) Counters

(K) Timers

(L) Panel Meters

(M) Tacho / Speed / Pulse Meters

(N) Display Units

(O) Sensor Controllers

(P) Switching Mode Power Supplies

(Q) Stepper Motors & Drivers & Controllers

(R) Graphic/ Logic Panels

(S) Field Network Devices

(T) Software

AiS-D Series

© SW2: Micro step setting switch (resolution)

-Set the micro step resolution of driver.

-The number of pulses per 1 rotation by resolution is each 500, 1000, 1600, 2000, 3200, 3600, 5000, 6400, 7200, 10000.

-Modified setting values are not applied in the running status, and the values will be applied after motor stopped.

Setting switch	Setting	Pulse/Revolution	Resolution
 RES.	0 (factory default)	500	2.5
	1	1000	5
	2	1600	8
	3	2000	10
	4	3200	16
	5	3600	18
	6	5000	25
	7	6400	32
	8	7200	36
	9	10000	50

© SW3: In-Position setting switch

-After position command pulse has finished, if the gap between target position and real position is under In-Position setting value, positioning completion pulse is output.

-Modified setting values are not applied in the running status, and the values will be applied after motor stopped.

Setting switch	Setting	Value	Setting	Value
	Fast response		Accurate response	
 INP.	0 (factory default)	0	8	0
	1	1	9	1
	2	2	A	2
	3	3	B	3
	4	4	C	4
	5	5	D	5
	6	6	E	6
	7	7	F	7

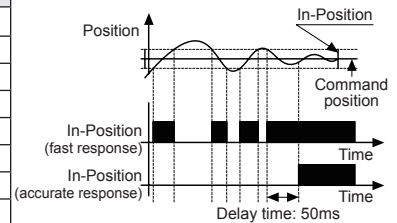

© SW4: Function selection DIP switch

-Set rotation direction, pulse input method, STOP current, SW1 setting, and test mode.

Setting switch	No.	Name	Function	Switch position	
				ON	OFF (factory default)
	1 ^{※1}	DIR	Rotation direction	CCW	CW
	2 ^{※1}	1P/2P	Pulse input method	1-pulse input method	2-pulse input method
	3 ^{※2}	C.D.	STOP current	25% of max. RUN current	50% of max. RUN current
	4 ^{※2}	SW1 Mode	SW1 setting	Position control gain	Motor drive response
	5 ^{※3}	Reserved	Test mode	Test mode	Normal mode

※1: When motor runs or stops, modified setting values will be applied immediately.

※2: Modified setting values are not applied in the running status, and the values will be applied after motor stopped.

※3: Set to OFF when using the device. It is only for operation test in manufacturing process.

• Pulse input method

※1-pulse method

CW: rotation operation signal input

CCW: rotation direction signal input

([H]: forward rotation, [L]: reverse rotation)

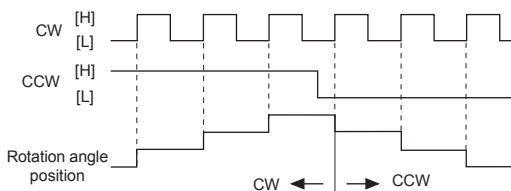

※2-pulse method

CW: forward rotation signal input

CCW: reverse rotation signal input

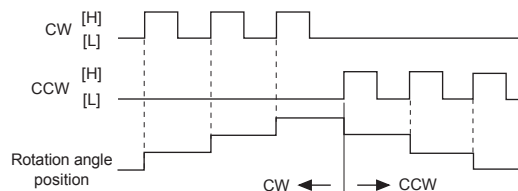

※[H]: photocoupler ON (voltage of both ends 4-8VDC) [L]: photocoupler OFF (voltage of both ends 0-0.5VDC)

• STOP current

-When it stops (if there is no input during twice of the last input pulse width), set the stop current supplied at the motor phase to decrease motor heat and current consumption.

2-Phase Closed-Loop Stepper Motor Driver

■ Control Input/Output

Inner signal of all input/output consists of photocoupler.
ON, [H]: photocoupler power ON / OFF, [L]: photocoupler power OFF.

◎ Input

1. Position command pulse

- Pulse input is selectable from 1-pulse input method and 2-pulse input method. (Refer to '◎SW4: Function selection DIP switch'.)
- When using extending cable, it is recommended to connect Common mode choke coil (2mH) to the CW, CCW terminal in series connection.

2. Servo On/Off

- This signal is for rotating axis of motor using external force or used for manual positioning.
- Servo On/Off signal maintains over 1ms as [H]: Regarded as Servo Off signal. Phase current is cut to release torque. The Servo ON indicator, the In-Position output and indicator turns OFF.
- Servo On/Off signal maintains over 1ms as [L]: Regarded as Servo On signal. Phase current is supplied to gain torque. The Servo ON indicator, the In-Position output and indicator turns ON.

- ※ Stop the motor for using this signal.
- ※ Refer to example of input circuit connection.

3. Alarm Reset

- This signal is for clearing the alarm.
- When alarm reset signal maintains over 20ms as [H], alarm is cleared. The alarm LED and alarm output turns OFF and the driver returns to normal status.
- ※ If the alarm causes are not removed clearly and using alarm reset, driver may not be returned at the normal status.
- ※ Refer to example of input circuit connection.

4. Example of input circuit connection

● Input pulse (CW, CCW)

- It is recommended to use 5VDC at V_{CC} and short the R_L .
- In case V_{CC} is over 5VDC, calculate R_L value using following formula and use V_{CC} below 30VDC
- In case V_{CC} is 12, 24VDC, refer to table on the right for R_L .

$$\times R_L = \frac{V_{CC} - 2.17V}{0.011A} - 220\Omega$$

V_{CC}	R_L
12VDC	680Ω (min. 0.25W)
24VDC	1.8kΩ (min. 0.5W)

(A)	Photoelectric Sensors
(B)	Fiber Optic Sensors
(C)	Door/Area Sensors
(D)	Proximity Sensors
(E)	Pressure Sensors
(F)	Rotary Encoders
(G)	Connectors/ Connector Cables/ Sensor Distribution Boxes/Sockets
(H)	Temperature Controllers
(I)	SSRs / Power Controllers
(J)	Counters
(K)	Timers
(L)	Panel Meters
(M)	Tacho / Speed / Pulse Meters
(N)	Display Units
(O)	Sensor Controllers
(P)	Switching Mode Power Supplies
(Q)	Stepper Motors & Drivers & Controllers
(R)	Graphic/ Logic Panels
(S)	Field Network Devices
(T)	Software

A. Pull-Up

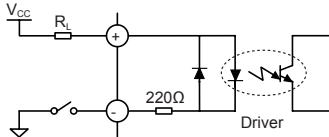

B. Pull-Down

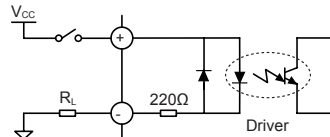

C. Circuit with NPN (not-reversed)

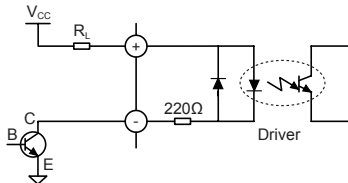

D. Circuit with PNP (reversed)

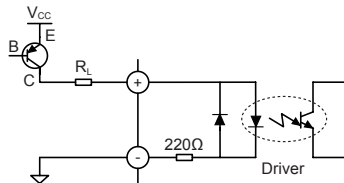

● External input (Servo On/Off, Alarm Reset)

A. Pull-Up

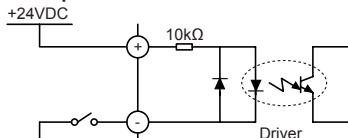

B. Pull-Down

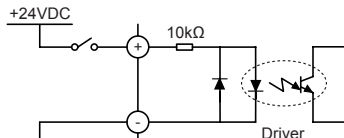

C. Circuit with NPN (not-reversed)

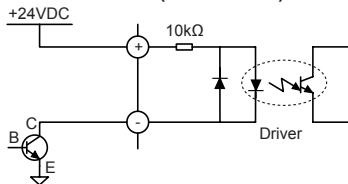

D. Circuit with PNP (reversed)

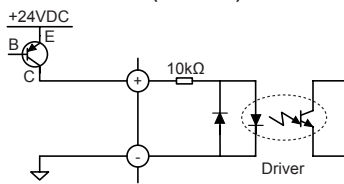

◎ Output

1. In-Position

- In-Position output represents output condition of positioning completion signal.
- If the gap between target position and real position is under In-Position setting value after position command pulse has finished, In-Position output turns to [H] and In-Position indicator turns ON.
- In reverse, when the gap is over In-Position setting value, In-Position output turns to [L] and In-Position indicator turns OFF.
- For accurate drive, check the In-Position output again and execute the next drive.
- ※ Refer to example of output circuit connection.

AiS-D Series

2. Alarm/Warning

• Alarm

- This function stops motor to protect driver, depending on the error status such as over current or over speed.
- In case of normal status, output is [H], and in case of alarming status, output is [L].
- When supplying alarm reset, driver returns to the normal status.

※Refer to example of output circuit connection.

• Warning

- This function notices dangers with the alarm indicator prior to over load alarm.
- When turning out from the alarming condition, driver returns to the normal status automatically.

Alarm indicator	No. of flashing	Alarm type	Descriptions	Motor stop	Maintain torque
AL (red)	1	Over current error	When over current flows at motor RUN element	O	x
	2	Over speed error	When motor speed is over 4,000rpm		
	3	Position tracking error	When the gap between position command value and current position value is over 90°		
	4	Over load error	When applying load over the rated load for over 1 sec		
	5	Over heat error	When driver inner temperature is over 80°C		
	6	Motor connection error	When motor cable connection error occurs at driver		
	7	Encoder connection error	When encoder cable connection error occurs at driver		
	8	Regenerative voltage error	When regenerative voltage is over 78V		
	9	Motor misalignment	When motor is in misalignment		
	10	Command pulse error	When Input pulse is over 3,500rpm		
	11	Input voltage error	When Input voltage is out of 24VDC±10%		
	12	In-Position error	When position error (over 1) is kept over 3 sec, after motor stopped.		
Warning indicator	No. of flashing	Warning type	Descriptions	Motor stop	Maintain torque
PWR (green)	4	Over load warning	When maximum load is kept connected over 10 sec. (motor or driver can be overheated)	x	O

※Although the driver normally operates in alarming status, the driver can be damaged.

Please operate the driver, avoiding alarming situation.

※Depending on alarm/warning type, indicators flash with interval of 0.4 sec and turn OFF with interval of 0.8 sec.

< E.g. case of alarm 3 >

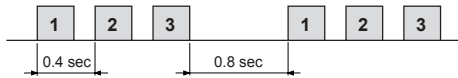

3. Example of output circuit connection

- It is recommended to use below 50VDC at VCC. Use the R_L for I_C (collector current of secondary detector) of photo coupler inside the driver to be within 25mA following the below formula.

$$\text{※A: } R_L = \frac{V_{CC} - 0.3V - V_F}{0.025A} - 10\Omega \quad \text{※B, C: } R_L = \frac{V_{CC} - 0.3V}{0.025A} - 10\Omega$$

(V_F is LED forward voltage of primary photocoupler.)

A. Circuit with photocoupler

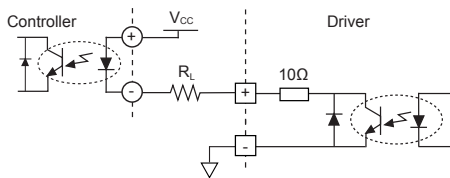

B. Circuit with pull up (reversed)

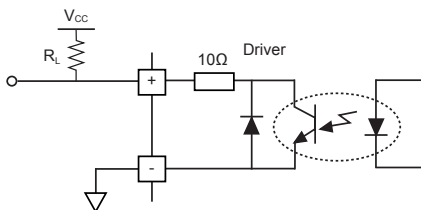

C. Circuit with pull down (not-reversed)

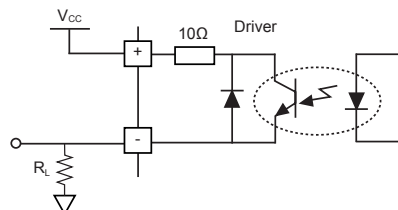

2-Phase Closed-Loop Stepper Motor Driver

4. Encoder output waveforms

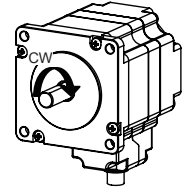
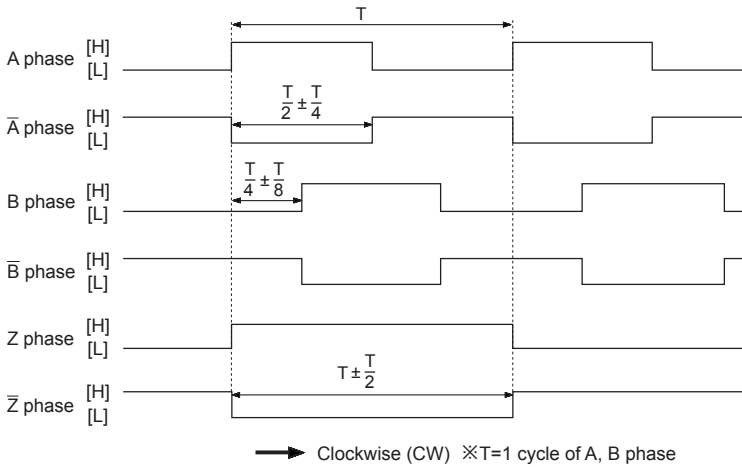

※It is recommended to use Line driver output (corresponding to 26C32) at RECEIVER end of encoder output and terminating resistors (100-150Ω) in parallel at both ends of each phase (A, \bar{A} , B, \bar{B} , Z, \bar{Z} , corresponding to 26C31).

■ Connection Connectors of Driver

◎ Connector function

● Power connector (CN1)

Pin arrangement	Pin no.	Function
	2	GND
	1	24VDC

● Motor+Encoder Connector (CN2)

Pin arrangement	Pin no.	Function	Pin no.	Function
	1	GND	8	+5VDC
	2	Encoder A	9	Encoder \bar{A}
	3	Encoder B	10	Encoder \bar{B}
	4	Encoder Z	11	Encoder \bar{Z}
	5	F.G.	12	N-C
	6	Motor A	13	Motor B
	7	Motor \bar{A}	14	Motor \bar{B}

● I/O connector (CN3)

Pin arrangement	Pin no.	Input/Output	Function	Pin no.	Input/Output	Function
	1	Input	CW+	11	Output	In-Position+
	2	Input	CW-	12	Output	In-Position-
	3	Input	CCW+	13	—	N-C
	4	Input	CCW-	14	—	N-C
	5	Input	Servo On/Off+	15	Output	Encoder A
	6	Input	Servo On/Off-	16	Output	Encoder \bar{A}
	7	Output	Alarm out+	17	Output	Encoder B
	8	Output	Alarm out-	18	Output	Encoder \bar{B}
	9	Input	Alarm reset+	19	Output	Encoder Z
	10	Input	Alarm reset-	20	Output	Encoder \bar{Z}

(A) Photoelectric Sensors

(B) Fiber Optic Sensors

(C) Door/Area Sensors

(D) Proximity Sensors

(E) Pressure Sensors

(F) Rotary Encoders

(G) Connectors/ Connector Cables/ Sensor Distribution Boxes/Sockets

(H) Temperature Controllers

(I) SSRs / Power Controllers

(J) Counters

(K) Timers

(L) Panel Meters

(M) Tacho / Speed / Pulse Meters

(N) Display Units

(O) Sensor Controllers

(P) Switching Mode Power Supplies

(Q) Stepper Motors & Drivers & Controllers

(R) Graphic/ Logic Panels

(S) Field Network Devices

(T) Software

AiS-D Series

◎ Connector specifications

Type		Specifications			Manufacture
		Connector	Connector terminal	Housing	
CN1	Driver	0039301020	—	—	Molex
	Power	CHD1140-02	CTD1140	—	HANLIM
CN2	Driver	35318-1420	—	—	Molex
	Motor+Encoder	5557-14R	5556T	—	Molex
CN3	Driver	10220-52A2 PL	—	—	3M
		10120-3000PE	—	10320-52F0-008	3M
	I/O connector	CJ-MP20-HP□ (sold separately)	—	—	Autonics

※Above connectors are suitable for AiS Series. You can use equivalent or substitute connectors.

◎ Cable (sold separately)

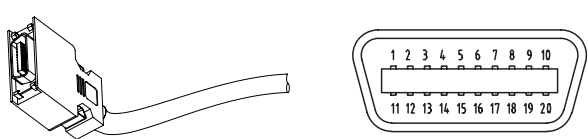
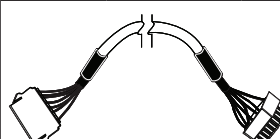
Type	Model					
I/O cable	CJ-MP20-HP□ (sold separately) ^{※1}					
						
	Pin no.	Cable color	Dot line color-numbers	Pin no.	Cable color	Dot line color-numbers
	1	Yellow	Black-1	11	White	Black-1
	2		Red-1	12		Red-1
	3		Black-2	13		Black-2
	4		Red-2	14		Red-2
	5		Black-3	15		Black-3
	6		Red-3	16		Red-3
	7		Black-4	17		Black-4
	8		Red-4	18		Red-4
9	Black-5		19	Black-5		
10	Red-5		20	Red-5		
Motor+Encoder cable						
	Normal	C1D14M-□ ^{※2}				
	Moving	C1DF14M-□ ^{※2}				

※1: □ indicates cable length (010, 020, 030, 050, 070, 100)
E.g.) CJ-MP20-HP070: 7m I/O cable

※2: □ indicates cable length (1, 2, 3, 5, 7, 10)

E.g.) C1DF14M-10: 10m moving type motor+encoder cable.

2-Phase Closed-Loop Stepper Motor Driver

■ Connection for Motor and Driver

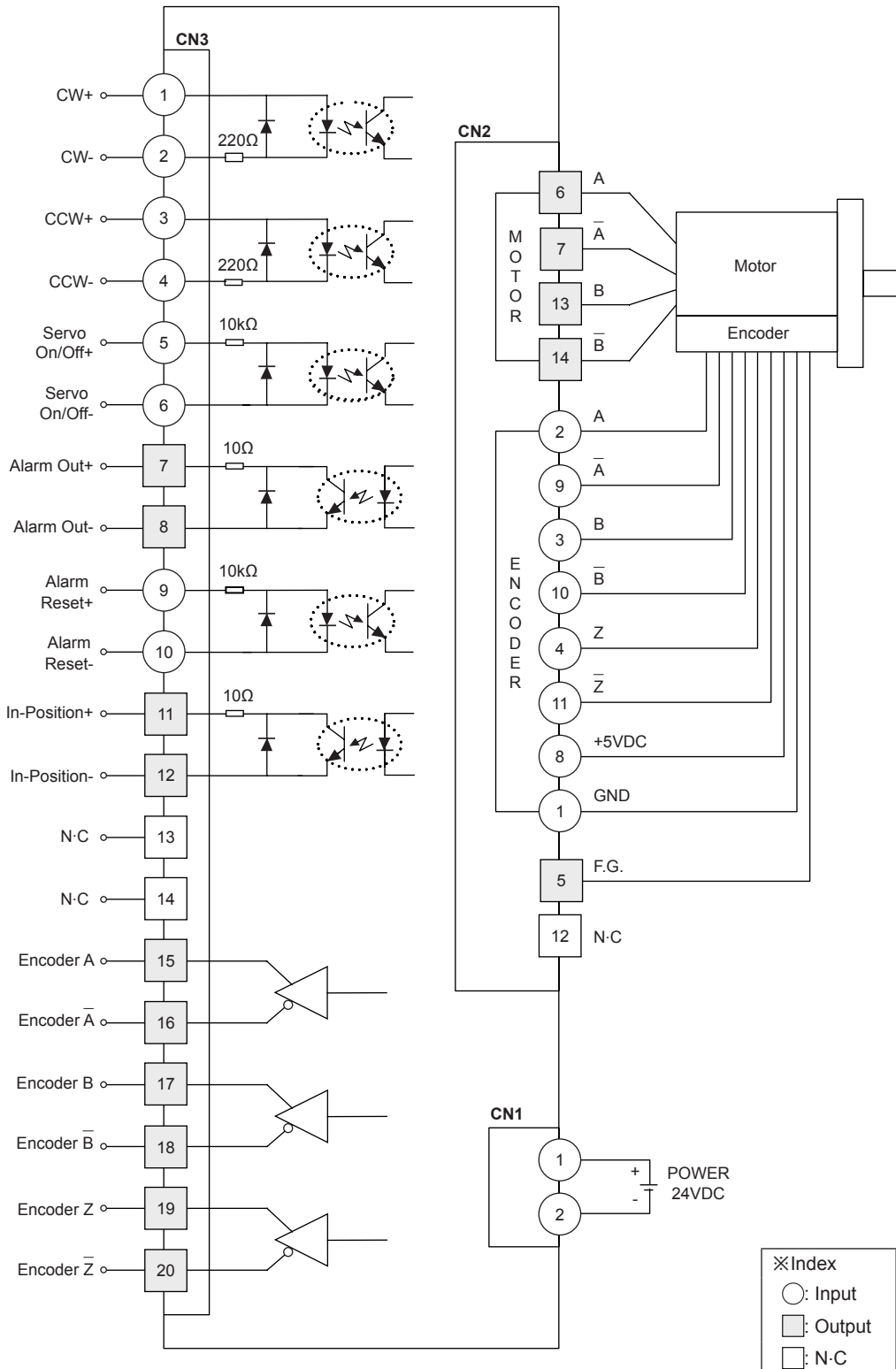

(A)	Photoelectric Sensors
(B)	Fiber Optic Sensors
(C)	Door/Area Sensors
(D)	Proximity Sensors
(E)	Pressure Sensors
(F)	Rotary Encoders
(G)	Connectors/ Connector Cables/ Sensor Distribution Boxes/Sockets
(H)	Temperature Controllers
(I)	SSRs / Power Controllers
(J)	Counters
(K)	Timers
(L)	Panel Meters
(M)	Tacho / Speed / Pulse Meters
(N)	Display Units
(O)	Sensor Controllers
(P)	Switching Mode Power Supplies
(Q)	Stepper Motors & Drivers & Controllers
(R)	Graphic/ Logic Panels
(S)	Field Network Devices
(T)	Software

■ Troubleshooting

1. When motor does not rotate

- ① Check the connection status between controller and driver, and pulse input specifications (voltage, width).
- ② Check the pulse and direction signal are connected correctly.

2. When motor rotates to the opposite direction of the designated direction

- ① When RUN mode is 1-pulse input method, CCW input [H] is for forward, [L] is for backward.
- ② When RUN mode is 2-pulse input method, check CW and CCW pulse input are changed or not.

3. When motor drive is unstable

- ① Check that driver and motor are connected correctly.
 - ② Check the driver pulse input specifications (voltage, width).
-

■ Proper Usage

1. 24VDC power supply should be insulated and limited voltage/current or Class 2, SELV power supply device.

2. Caution for signal input

If the signal input supply is higher than rated supply in the specification, connect the additional resistance to external part.

3. Caution for wiring (※Autonics cable are recommended)

- ① Use twisted pair shield wire (min. 0.2mm²) for signal line.
- ② The thickness of cable should be same or thicker than the motor cable's when extending the motor cable.
- ③ Must separate between the signal cable and the power cable over 10cm.

4. Caution for installation

For heat radiation when installing this unit, contact this driver base tightly with the metal surface.

When using this unit, over heat error occur, install a fan for heat radiation or change the installation placement.

5. Caution for re-supplying power

Re-supply power after min. 1 sec from disconnected power.

6. Motor vibration and noise can occur in specific frequency period

- ① Motor vibration and noise can be lowered by change motor installation or attach damper.
- ② Use the unit in a range without vibration and noise range by RUN speed adjustment.

7. Using at low temperature

Using motors at low temperature may cause reducing maximum starting / driving characteristics of the motor due to decreased ball bearing's grease consistency. Start the motor in a steady manner since motor's torque is not to be influenced.

8. Temperature rise

The surface temperature of motor shall be under 100°C and it can be significantly increased by operation conditions (ambient temperature, drive speed, drive duty ratio, etc). In this case, use the cooling fan to lower the temperature forcibly. It may cause for motor power cable to be damaged by fire, for inner ball-bearing of motor to be shortening the life cycle or for the unit to malfunction.

9. Insulation resistance measurement, Dielectric strength test

When executing insulation resistance measurement or dielectric strength test when motor and driver are connected, it may cause damage to the unit.

10. Encoder wire connection

- ① Do not draw the wire with over strength 30N after wiring.
- ② If wire encoder cable with high voltage line or power cable in the same conduit, it may cause a malfunction or mechanical problem.
Please wire it separately or use separated conduit.
- ③ Check the cable type and response frequency before using the unit. The cable length should be as short as possible.
If not, it may cause increase cable resistance, residual voltage, and output waveform noise
- ④ Must connect the shield cable to the F.G. terminal.

11. Maintenance, Inspection

For using motor, it is recommended to maintenance and inspection regularly.

If motor has error, do not use the motor. Take maintenance and inspection before using it.

Maintenance and inspection items are as below.

- ① Unwinding bolt and connection parts for the unit installation and load connection
- ② Strange sound from ball bearing of the unit
- ③ Damage and stress of lead cable of the unit
- ④ Connection error with driver
- ⑤ Inconsistency between the axis of motor output and the center, concentric (eccentric, declination) of the load, etc.

12. This product may be used in the following environments

- ① Indoors
- ② Altitude max. 2,000m
- ③ Pollution degree 2
- ④ Installation category II