

# Ai-M-B Series

NEW

## Built-in Brake Type 2-Phase Closed-Loop Stepper Motor

### ■ Features

- Brake force is released when applying power on brake wire
- Minimal heat generating, high torque motor (control voltage 55V)
- Higher cost-efficiency compared to servo motors
- Frame size 42mm, 56mm, 60mm supported
- Applied driver: AiS-D-B series

⚠ Please read "Safety Considerations" in operation manual before using.



[Frame size 42mm]



[Frame size 56mm]



[Frame size 60mm]

### ■ Ordering Information

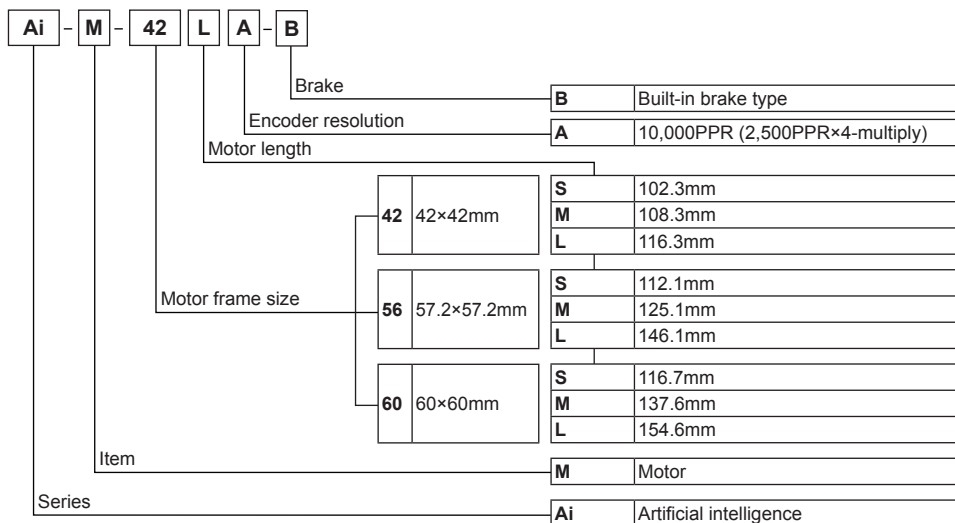

### ○ AiS-B Series

Set	Driver	Motor
AiS-42SA-B	AiS-D-42SA-B	Ai-M-42SA-B
AiS-42MA-B	AiS-D-42MA-B	Ai-M-42MA-B
AiS-42LA-B	AiS-D-42LA-B	Ai-M-42LA-B
AiS-56SA-B	AiS-D-56SA-B	Ai-M-56SA-B
AiS-56MA-B	AiS-D-56MA-B	Ai-M-56MA-B
AiS-56LA-B	AiS-D-56LA-B	Ai-M-56LA-B
AiS-60SA-B	AiS-D-60SA-B	Ai-M-60SA-B
AiS-60MA-B	AiS-D-60MA-B	Ai-M-60MA-B
AiS-60LA-B	AiS-D-60LA-B	Ai-M-60LA-B

# Built-in Brake Type 2-Phase Closed-Loop Stepper Motor

## ■ Specifications

### ◎ Motor

#### ● Frame size 42mm

Model	Ai-M-42SA-B	Ai-M-42MA-B	Ai-M-42LA-B
Max. holding torque <sup>*1</sup>	2.55kgf·cm (0.25N·m)	4.08kgf·cm (0.4N·m)	4.89kgf·cm (0.48N·m)
Rotor moment of inertia	35g·cm <sup>2</sup> (35×10 <sup>-7</sup> kg·m <sup>2</sup> )	54g·cm <sup>2</sup> (54×10 <sup>-7</sup> kg·m <sup>2</sup> )	77g·cm <sup>2</sup> (77×10 <sup>-7</sup> kg·m <sup>2</sup> )
Rated current	1.7A/Phase		
Resistance	1.7Ω/Phase ±10%	1.85Ω/Phase ±10%	2.1Ω/Phase ±10%
Inductance	1.9mH/Phase ±20%	3.5mH/Phase ±20%	4.4mH/Phase ±20%
Weight <sup>*2</sup>	Approx. 0.77kg (approx. 0.67kg)	Approx. 0.83kg (approx. 0.73kg)	Approx. 0.90kg (approx. 0.80kg)

#### ● Frame size 56mm

Model	Ai-M-56SA-B	Ai-M-56MA-B	Ai-M-56LA-B
Max. holding torque <sup>*1</sup>	6.12kgf·cm (0.6N·m)	12.24kgf·cm (1.2N·m)	20.39kgf·cm (2.0N·m)
Rotor moment of inertia	140g·cm <sup>2</sup> (140×10 <sup>-7</sup> kg·m <sup>2</sup> )	280g·cm <sup>2</sup> (280×10 <sup>-7</sup> kg·m <sup>2</sup> )	480g·cm <sup>2</sup> (480×10 <sup>-7</sup> kg·m <sup>2</sup> )
Rated current	3.5A/Phase		
Resistance	0.55Ω/Phase ±10%	0.57Ω/Phase ±10%	0.93Ω/Phase ±10%
Inductance	1.05mH/Phase ±20%	1.8mH/Phase ±20%	3.7mH/Phase ±20%
Weight <sup>*2</sup>	Approx. 1.30kg (approx. 1.15kg)	Approx. 1.52kg (approx. 1.38kg)	Approx. 1.90kg (approx. 1.75kg)

#### ● Frame size 60mm

Model	Ai-M-60SA-B	Ai-M-60MA-B	Ai-M-60LA-B
Max. holding torque <sup>*1</sup>	11.22kgf·cm (1.1N·m)	22.43kgf·cm (2.2N·m)	29.57kgf·cm (2.9N·m)
Rotor moment of inertia	240g·cm <sup>2</sup> (240×10 <sup>-7</sup> kg·m <sup>2</sup> )	490g·cm <sup>2</sup> (490×10 <sup>-7</sup> kg·m <sup>2</sup> )	690g·cm <sup>2</sup> (690×10 <sup>-7</sup> kg·m <sup>2</sup> )
Rated current	3.5A/Phase		
Resistance	1.0Ω/Phase ±10%	1.23Ω/Phase ±10%	1.3Ω/Phase ±10%
Inductance	1.5mH/Phase ±20%	2.6mH/Phase ±20%	3.8mH/Phase ±20%
Weight <sup>*2</sup>	Approx. 1.53kg (approx. 1.36kg)	Approx. 1.90kg (approx. 1.74kg)	Approx. 2.23kg (approx. 2.07kg)

※1: Max. holding torque is maintenance torque of stopping the motor when supplying the rated current (2-phase excitation) and is the standard for comparing the performance of motors.

※2: The weight includes packaging. The weight in parenthesis is for unit only.

#### ● Common specifications

Standard step angle	1.8°/0.9° (Full/Half step)	
Motor phase	2-phase	
Run method	Bipolar	
Insulation class	B type (130°C)	
Insulation resistance	Over 100MΩ (at 500VDC megger), between motor coil-case	
Dielectric strength	500VAC 50/60Hz for 1 min between motor coil-case	
Vibration	1.5mm amplitude at frequency 10 to 55Hz (for 1 min) in each X, Y, Z direction for 2 hours	
Shock	Approx. max. 50G	
Environment	Ambient temperature	0 to 50°C, storage: -20 to 70°C
	Ambient humidity	20 to 85%RH, storage: 15 to 90%RH
Approval	CE	
Protection structure	IP30 (IEC34-5 standard)	
Stop angle error <sup>*1</sup>	±0.09°	
Shaft vibration <sup>*2</sup>	0.03mm T.I.R.	
Radial Movement <sup>*3</sup>	Max. 0.025mm (load 25N)	
Axial Movement <sup>*4</sup>	Max. 0.01mm (load 50N)	
Concentricity for shaft of setup in-low	0.05mm T.I.R.	
Perpendicularity of set-up plate shaft	0.075mm T.I.R.	

※1: Specifications are for full-step angle, without load. (values may vary by load size)

※2: T.I.R. (Total Indicator Reading)

- Indicates total quantity of dial gauge in case of 1 rotation of measuring part around the reference point.

※3: Amount of radial shaft displacement when adding a radial load (25N) to the tip of the motor shaft.

※4: Amount of axial shaft displacement when adding a axial load (50N) to the shaft.

※Environment resistance is rated at no freezing or condensation.

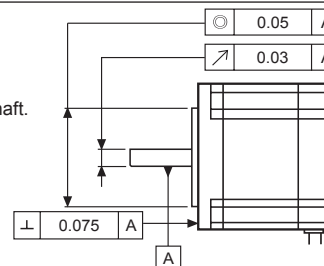

(A) Photoelectric Sensors

(B) Fiber Optic Sensors

(C) Door/Area Sensors

(D) Proximity Sensors

(E) Pressure Sensors

(F) Rotary Encoders

(G) Connectors/ Connector Cables/ Sensor Distribution Boxes/Sockets

(H) Temperature Controllers

(I) SSRs / Power Controllers

(J) Counters

(K) Timers

(L) Panel Meters

(M) Tacho / Speed / Pulse Meters

(N) Display Units

(O) Sensor Controllers

(P) Switching Mode Power Supplies

(Q) Stepper Motors & Drivers & Controllers

(R) Graphic/ Logic Panels

(S) Field Network Devices

(T) Software

# Ai-M-B Series

## Specifications

### Brake

	Frame size 42mm	Frame size 56mm	Frame size 60mm
Rated excitation voltage*1	24VDC $\pm$ 10%		
Rated excitation current	0.208A	0.275A	
Static friction torque	Min. 1.8kgf·cm	Min. 8.0kgf·cm	
Rotation part inertia	6g·cm <sup>2</sup>	19g·cm <sup>2</sup>	
Insulation class	B type (130 °C)		
B type brake	Power on: brake is released, power off: brake is operating		
Operating time	Max. 25ms	Max. 30ms	
Releasing time	Max. 10ms	Max. 20ms	

\*1: Driver reduces power voltage from 24VDC to 11.5VDC and control the motor to reduce heat generation in the brake which is connected with the motor.

### Encoder

Item	Incremental rotary encoder		
Resolution	10,000PPR (2,500PPR×4-multiply)		
Electrical specification	Output phase	A, $\bar{A}$ , B, $\bar{B}$ , Z, $\bar{Z}$ phase	
	Output duty rate	$\frac{T}{2} \pm \frac{T}{4}$ (T=1 cycle of A phase)	
	Phase difference of output	Output between A and B phase: $\frac{T}{4} \pm \frac{T}{8}$ (T=1 cycle of A phase)	
	Control output	Line driver output	<ul style="list-style-type: none"> <li>• [Low] - Load current: max. 20mA, residual voltage: max. 0.5VDC</li> <li>• [High] - Load current: max. -20mA, output voltage: min. 2.5VDC</li> </ul>
	Response time (rise, fall)	Max. 0.5 $\mu$ s (cable length: 2m, I sink = 20mA)	
	Max. response frequency	300kHz	
	Power supply	5VDC $\pm$ 5% (ripple P-P: max. 5%)	
	Current consumption	Max. 50mA (disconnection of the load)	

## Encoder Control Output Diagram

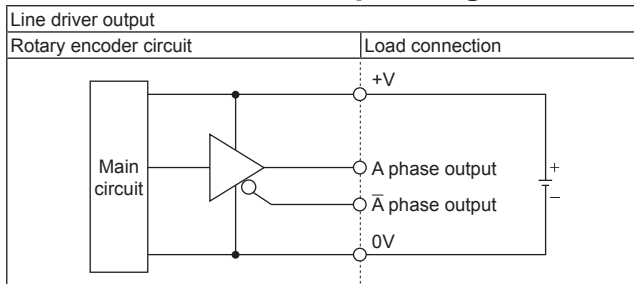

\*All output circuits of A,  $\bar{A}$ , B,  $\bar{B}$ , Z,  $\bar{Z}$  phase are the same.

## Encoder Output Waveforms

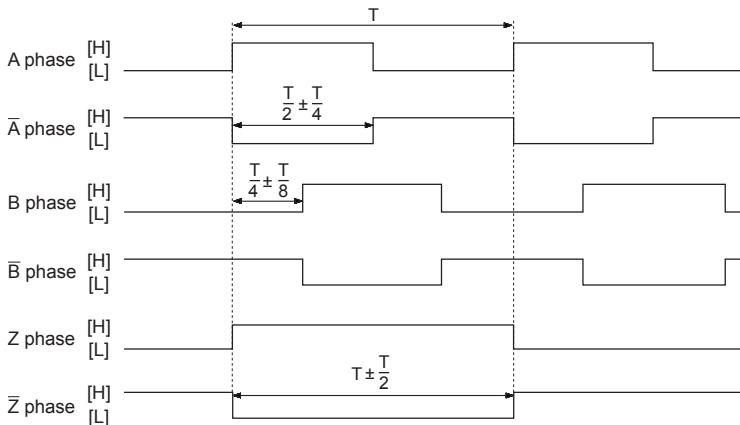

→ Clockwise (CW) \*T=1 cycle of A, B phase

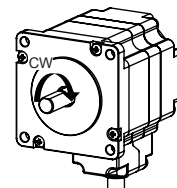

# Built-in Brake Type 2-Phase Closed-Loop Stepper Motor

## ■ Dimensions

### ○ Frame size 42mm

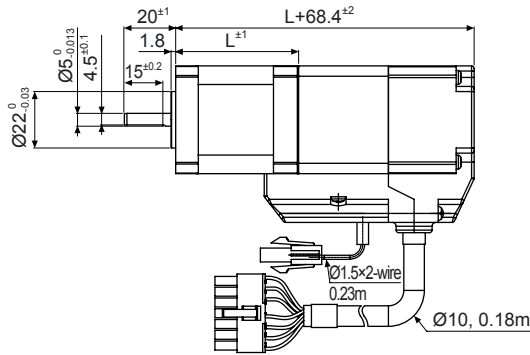
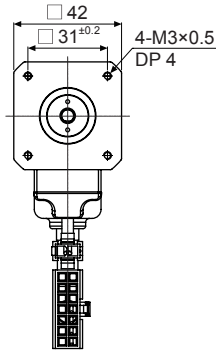

Model	L
Ai-M-42SA-B	33.9
Ai-M-42MA-B	39.9
Ai-M-42LA-B	47.9

### ○ Frame size 56mm

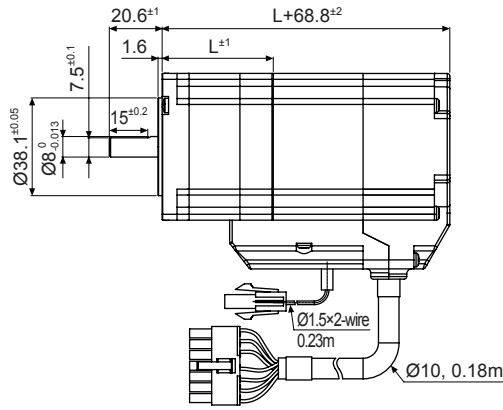
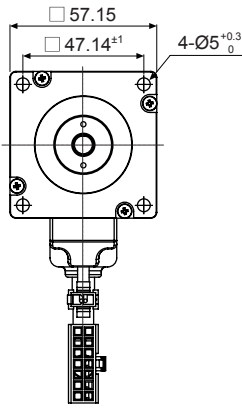

Model	L
Ai-M-56SA-B	43.3
Ai-M-56MA-B	56.3
Ai-M-56LA-B	77.3

### ○ Frame size 60mm

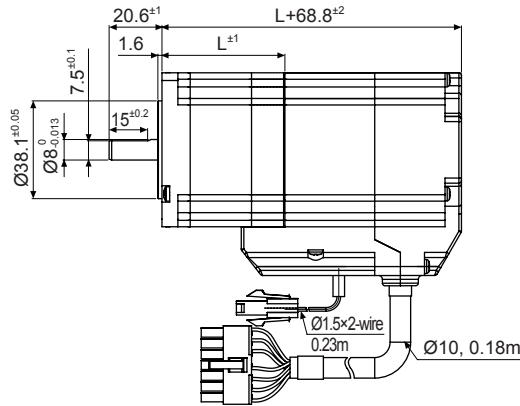
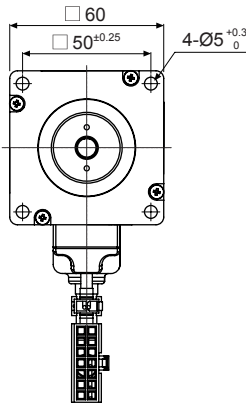

Model	L
Ai-M-60SA-B	47.9
Ai-M-60MA-B	68.8
Ai-M-60LA-B	85.8

## ■ Connection Diagram

Autonics 2-phase closed-loop stepper motors take bipolar wiring methods. The wiring colors for each phase and lead-wire are as the followings:

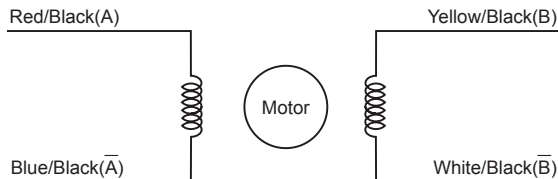

(unit: mm)

(A) Photoelectric Sensors

(B) Fiber Optic Sensors

(C) Door/Area Sensors

(D) Proximity Sensors

(E) Pressure Sensors

(F) Rotary Encoders

(G) Connectors/ Connector Cables/ Sensor Distribution Boxes/Sockets

(H) Temperature Controllers

(I) SSRs / Power Controllers

(J) Counters

(K) Timers

(L) Panel Meters

(M) Tacho / Speed / Pulse Meters

(N) Display Units

(O) Sensor Controllers

(P) Switching Mode Power Supplies

(Q) Stepper Motors & Drivers & Controllers

(R) Graphic/ Logic Panels

(S) Field Network Devices

(T) Software

# Ai-M-B Series

## Motor Characteristics

### Frame size 42mm

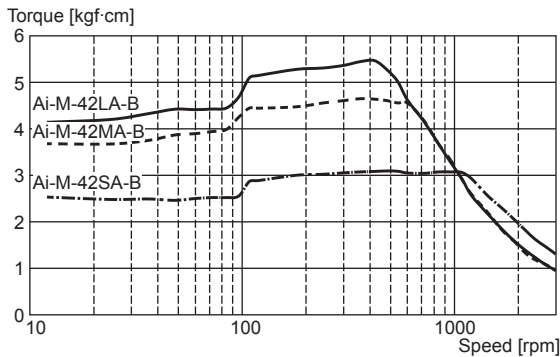

### Frame size 56mm

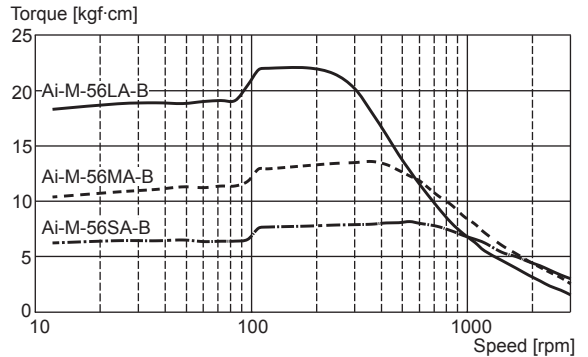

### Frame size 60mm

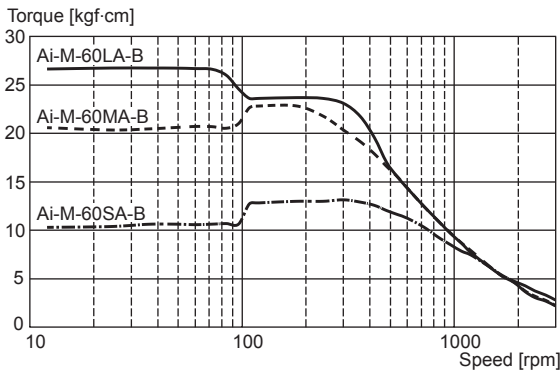

## Connection Connectors of Motor

### CN1: Power connector

Pin arrangement	Pin No.	Function
	1	24VDC
	2	GND

### CN2: Motor+Encoder connector

Pin arrangement	Pin No.	Function	Pin No.	Function
	1	GND	8	+5VDC
	2	Encoder A	9	Encoder $\bar{A}$
	3	Encoder B	10	Encoder $\bar{B}$
	4	Encoder Z	11	Encoder $\bar{Z}$
	5	F.G.	12	N-C
	6	Motor A	13	Motor B
	7	Motor $\bar{A}$	14	Motor $\bar{B}$

Type	Specifications			Manufacture
	Connector	Connector terminal	Housing	
CN1 Power	5559-02P	5558T	—	Molex
CN2 Motor+Encoder	5557-14R	5556T	—	Molex

※Above connectors are suitable for Ai-M-B Series.  
You can use equivalent or substitute connectors.

### Cable (sold separately)

Type	Model	
	Normal	Moving
	C1D14M-□*1	C1DF14M-□*1

※1: □ indicates cable length (1, 2, 3, 5, 7, 10).  
E.g.) C1DF14M-10: 10m moving type motor+encoder cable.

# Built-in Brake Type 2-Phase Closed-Loop Stepper Motor

## Motor Installation

### 1. Mounting direction

Motor can be mounted in any directions-facing up, facing down and side ways.  
No matter which direction motors to be mounted, make sure not to apply overhung or thrust load on the shaft.  
Refer to the table below for allowable shaft overhung load / thrust load.

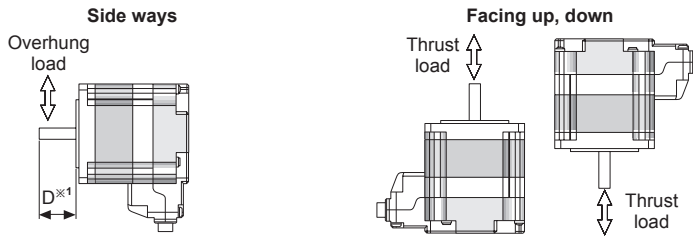

※1: The distance from the shaft in front (mm)

Motor size	The distance from the shaft in front (mm), Allowable overhung load [kgf (N)]				Allowable thrust load
	D=0	D=5	D=10	D=15	
Frame size 42mm	2 (20)	2.6 (25)	3.5 (34)	5.3 (52)	Under the load of motor
Frame size 56mm	5.5 (54)	6.8 (67)	9.1 (89)	13.3 (130)	
Frame size 60mm					

Do not apply excessive force to motor cable when mounting motors.  
Do not forcibly pull or insert the cable. It may cause poor connection or disconnection of the cable by force.  
In case of frequent cable movement required application, proper safety countermeasures must be ensured.

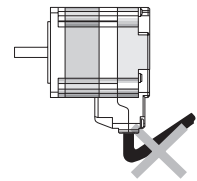

### 2. Mounting method

#### ○ Frame size 42mm

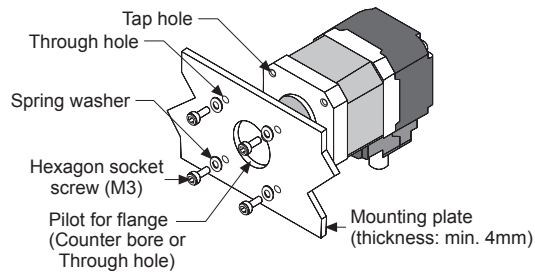
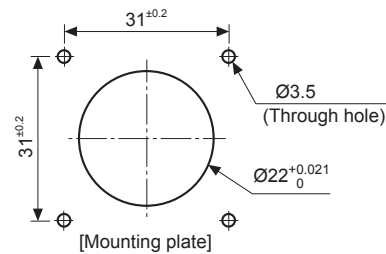

#### ○ Frame size 56mm/60mm

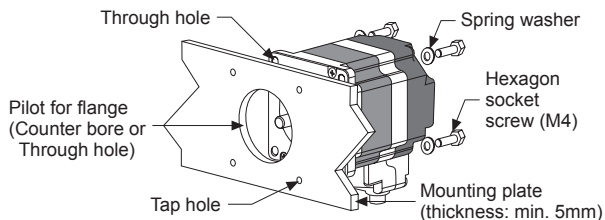
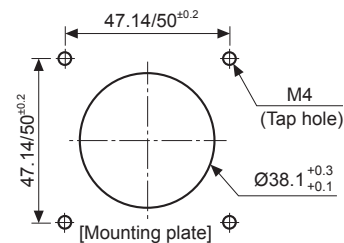
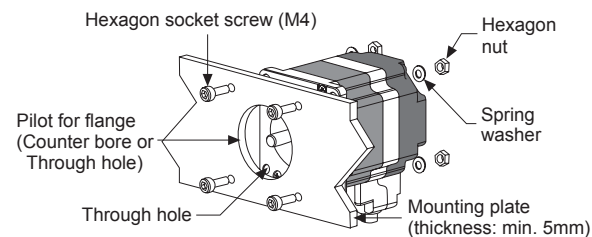
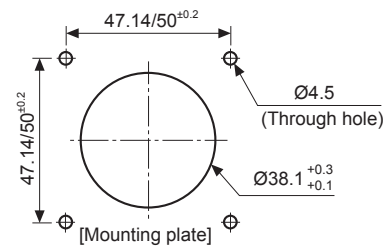

With considering heat radiation and vibration isolation, mount the motor as tight as possible against a metal panel having high thermal conductivity such as iron or aluminum.

When mounting motors, use hexagon socket screws, hexagon nuts, spring washers and flat washers.

Refer to the table below for allowable thickness of mounting plate and using bolt.

Do not draw the wire with over strength 30N after wiring the encoder.

- (A) Photoelectric Sensors
- (B) Fiber Optic Sensors
- (C) Door/Area Sensors
- (D) Proximity Sensors
- (E) Pressure Sensors
- (F) Rotary Encoders
- (G) Connectors/ Connector Cables/ Sensor Distribution Boxes/Sockets
- (H) Temperature Controllers
- (I) SSRs / Power Controllers
- (J) Counters
- (K) Timers
- (L) Panel Meters
- (M) Tacho / Speed / Pulse Meters
- (N) Display Units
- (O) Sensor Controllers
- (P) Switching Mode Power Supplies
- (Q) Stepper Motors & Drivers & Controllers
- (R) Graphic/ Logic Panels
- (S) Field Network Devices
- (T) Software

# Ai-M-B Series

## 3. Connection with load

When connecting the load, be sure of the center, tension of the belt, and parallel of the pulley.

When connecting the load such as a pulley, a belt, be sure of the allowable thrust load, radial load, and shock.

Tighten the screw for a coupling or a pulley not to be unscrewed.

When connecting a coupling or a pulley on the motor shaft, be sure of damage of the motor shaft and the motor shaft bearing.

Do not disassemble or modify the motor shaft to connect with the load.

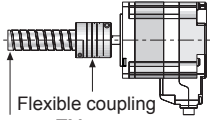
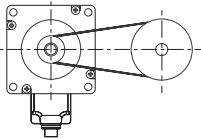
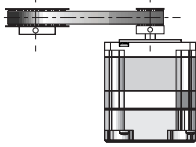
Direct load connection with coupling	Load connection with pulley, belt, and wire	Load connection with gear
 <p>Flexible coupling Ball screw or TM screw ※Use Autonics flexible coupling (ERB Series).</p>		
<p>When connecting the load directly (ball screw, TM screw, etc) to the motor shaft, use a flexible coupling as shown in the above figure. If the center of the load is not aligned with that of shaft, it may cause severe vibration, shaft damage or shorten life cycle of the shaft bearing.</p>	<p>The motor shaft and the load shaft should be parallel. Connect the motor shaft and the line which connects the center of two pulleys to a right angle.</p>	<p>The motor shaft and the load shaft should be parallel. Connect the motor shaft to the center of gear teeth side to be interlocked.</p>

## 4. Installation condition

Install the motor in a place that meets certain conditions specified below.

It may cause product damage if it is used out of following conditions.

- ① Inside of the housing which is installed indoors  
(This unit is manufactured for the purpose of attaching to equipment. Install a ventilation device.)
- ② Within 0 to 50°C (at non-freezing status) of ambient temperature
- ③ Within 20 to 85%RH (at non-dew status) of ambient humidity
- ④ The place without explosive, flammable and corrosive gas
- ⑤ The place without direct ray of light
- ⑥ The place where dust or metal scrap does not enter into the unit
- ⑦ The place without contact with water, oil, or other liquid
- ⑧ The place without contact with strong alkali or acidity
- ⑨ The place where easy heat dissipation could be made
- ⑩ The place without continuous vibration or severe shock
- ⑪ The place with less salt content
- ⑫ The place with less electronic noise occurs by welding machine, motor, etc.
- ⑬ The place where no radioactive substances and magnetic fields exist. It shall be no vacuum status as well.

## ■ Troubleshooting

### 1. When motor does not rotate

- ① Check the connection status between controller and driver, and pulse input specifications (voltage, width).
- ② Check the pulse and direction signal are connected correctly.

### 2. When motor rotates to the opposite direction of the designated direction

- ① When RUN mode is 1-pulse input method, CCW input [H] is for forward, [L] is for backward.
- ② When RUN mode is 2-pulse input method, check CW and CCW pulse input are changed or not.

### 3. When motor drive is unstable

- ① Check that driver and motor are connected correctly.
- ② Check the driver pulse input specifications (voltage, width).

# Built-in Brake Type 2-Phase Closed-Loop Stepper Motor

## ■ Proper Usage

- Follow instructions in 'Proper Usage'.  
Otherwise, it may cause unexpected accidents.
- Using motors at low temperature may cause reducing ball bearing's grease consistency and friction torque is increased.  
Start the motor in a steady manner since motor's torque is not to be influenced.
- When power is supplied or not to the brake, the unit may occur clack sound.
- When drive the motor, supply power to electro-magnetic brake for releasing the brake.  
When the brake pad is worn out, the product life cycle is shorten, the rated static friction torque is reduced.
- If wiring encoder cable, separate it from high voltage line or power cable for preventing surge and inductive noise. The cable length should be as short as possible.  
Failure to follow this instruction may result in raised cable resistance, residual voltage, and output waveform noise.
- Must connect the encoder shield cable to the F.G. terminal.
- For using motor, it is recommended to maintenance and inspection regularly.
  - ① Unwinding bolts and connection parts for the unit installation and load connection
  - ② Strange sound from ball bearing of the unit
  - ③ Damage and stress of lead cable of the unit
  - ④ Connection error with driver
  - ⑤ Inconsistency between the axis of motor output and the center, concentric (eccentric, declination) of the load, etc.
- This unit may be used in the following environments.
  - ① Indoors (in the environment condition rated in 'Specifications')
  - ② Altitude max. 2,000m
  - ③ Pollution degree 2
  - ④ Installation category II

(A)	Photoelectric Sensors
(B)	Fiber Optic Sensors
(C)	Door/Area Sensors
(D)	Proximity Sensors
(E)	Pressure Sensors
(F)	Rotary Encoders
(G)	Connectors/ Connector Cables/ Sensor Distribution Boxes/Sockets
(H)	Temperature Controllers
(I)	SSRs / Power Controllers
(J)	Counters
(K)	Timers
(L)	Panel Meters
(M)	Tacho / Speed / Pulse Meters
(N)	Display Units
(O)	Sensor Controllers
(P)	Switching Mode Power Supplies
(Q)	<b>Stepper Motors &amp; Drivers &amp; Controllers</b>
(R)	Graphic/ Logic Panels
(S)	Field Network Devices
(T)	Software