

User Manual for Communication

HMI

**GP/LP Series
(Autonics)**

Thank you for purchasing an Autonics product.
This user manual contains information about the product and its proper use,
and should be kept in a place where it will be easy to access.

Preface

Thank you for purchasing Autonics product.





Please familiarize yourself with the information contained in the Safety Considerations section before using this product.

This user manual contains information about the product and its proper use, and should be kept in a place where it will be easy to access.

User Manual Guide

- Please familiarize yourself with the information in this manual before using the product.
- This manual provides detailed information on the product's features. It does not offer any guarantee concerning matters beyond the scope of this manual.
- This manual may not be edited or reproduced in either part or whole without permission.
- A user manual is not provided as part of the product package. Please visit our website (www.autonics.com) to download a copy.
- The manual's content may vary depending on changes to the product's software and other unforeseen developments within Autonics, and is subject to change without prior notice. Upgrade notice is provided through our website.
- We contrived to describe this manual more easily and correctly. However, if there are any corrections or questions, please notify us these on our website.
- Inner device of this user manual for communication is based on GP.
If you use LP, refer to "LP user manual" for inner device of LP.

User Manual Symbols

| Symbol | Description |
|--|--|
|  Note | Supplementary information for a particular feature. |
|  Warning | Failure to follow instructions can result in serious injury or death. |
|  Caution | Failure to follow instructions can lead to a minor injury or product damage. |
|  Ex. | An example of the concerned feature's use. |
| ※1 | Annotation mark. |

Reference Manual for Each Configuration

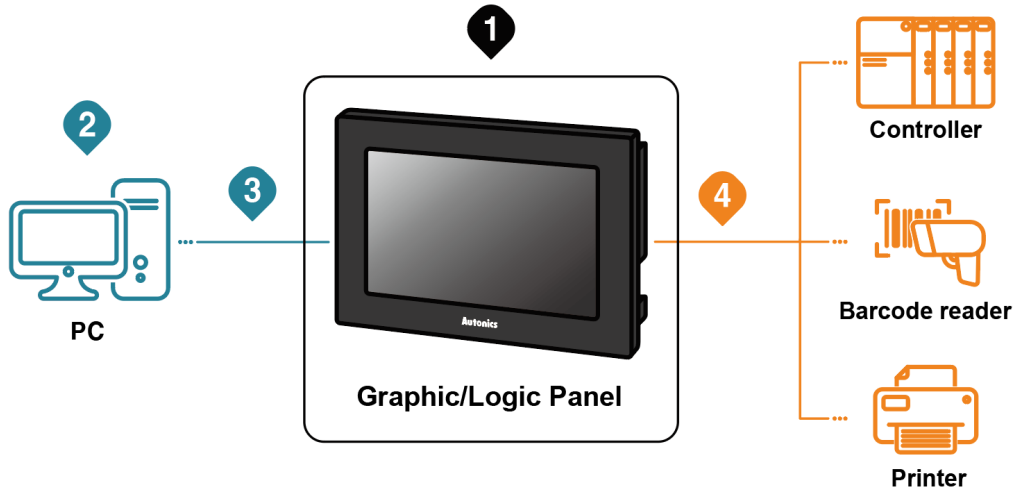

1 Graphic/Logic panel device specification, installation, maintenance, management, firmware update and system configuration

| | | |
|-----------------|----------|--|
| Hardware Manual | A Series | GP-A Series User Manual, LP-A Series User Manual |
| | S Series | GP-S070 User Manual, GP-S044/057 User Manual, LP-S070 User Manual, LP-S044 User Manual |

2 Project drawing, programming

| | | |
|-----------------|-------------|---|
| Software Manual | Drawing | atDesigner User Manual, GP Editor User Manual |
| | Programming | atLogic User Manual, atLogic Programming Manual |

3 Project Upload/Download

| | | |
|-----------------|----------|--|
| Hardware Manual | A Series | GP-A Series User Manual, LP-A Series User Manual |
| | S Series | GP-S070 User Manual, GP-S044/057 User Manual, LP-S070 User Manual, LP-S044 User Manual |

4 Connected device setting, communication setting

| | | |
|-----------------|-------------|--|
| Software Manual | Drawing | atDesigner User Manual, GP Editor User Manual |
| | Programming | atLogic User Manual, atLogic Programming Manual |
| Hardware Manual | A Series | GP-A Series User Manual, LP-A Series User Manual |
| | S Series | GP-S070 User Manual, GP-S044/057 User Manual, LP-S070 User Manual, LP-S044 User Manual |

4 Check connectable device, connection cable model name and protocol

| | |
|----------------------|----------------------------|
| Communication Manual | GP/LP Communication Manual |
|----------------------|----------------------------|

Table of Contents

| | |
|--|-----------|
| Preface | 3 |
| User Manual Guide | 4 |
| User Manual Symbols | 5 |
| Reference Manual for Each Configuration..... | 6 |
| Table of Contents | 7 |
| 1 System Organization | 9 |
| 1.1 1:1 Communication..... | 10 |
| 1.2 1:N Communication of Same Controllers..... | 11 |
| 1.3 1:N Communication of Different Controllers..... | 13 |
| 1.3.1 1:1:1 Communication | 13 |
| 1.3.2 1:1:N Communication..... | 14 |
| 1.3.3 N:1:N Communication | 16 |
| 1.4 Barcode Reader, Printer Communication..... | 17 |
| 1.4.1 Communication Configuration..... | 17 |
| 2 Communication Configuration by Devices..... | 21 |
| 2.1 Autonics Product..... | 21 |
| 2.1.1 Connection Support Products | 21 |
| 2.1.2 Connectable GP/LP Model..... | 21 |
| 2.1.3 System Organization..... | 22 |
| 2.1.4 Communication Cable | 23 |
| 2.1.5 Available Device..... | 24 |
| 2.1.6 Monitorable Device in GP/LP | 31 |
| 2.2 Connection to Autonics LP Series | 33 |
| 2.2.1 Connection Support Products | 33 |
| 2.2.2 Connectable GP/LP Model..... | 33 |
| 2.2.3 System Organization..... | 33 |
| 2.2.4 Communication Cable | 34 |
| 2.2.5 Available Device..... | 35 |
| 2.2.6 Monitorable Device in GP/LP | 37 |

1 System Organization

GP/LP can be connected with various controller, barcode reader and printer via RS232C, RS422, Ethernet, CAN and USB HOST port.

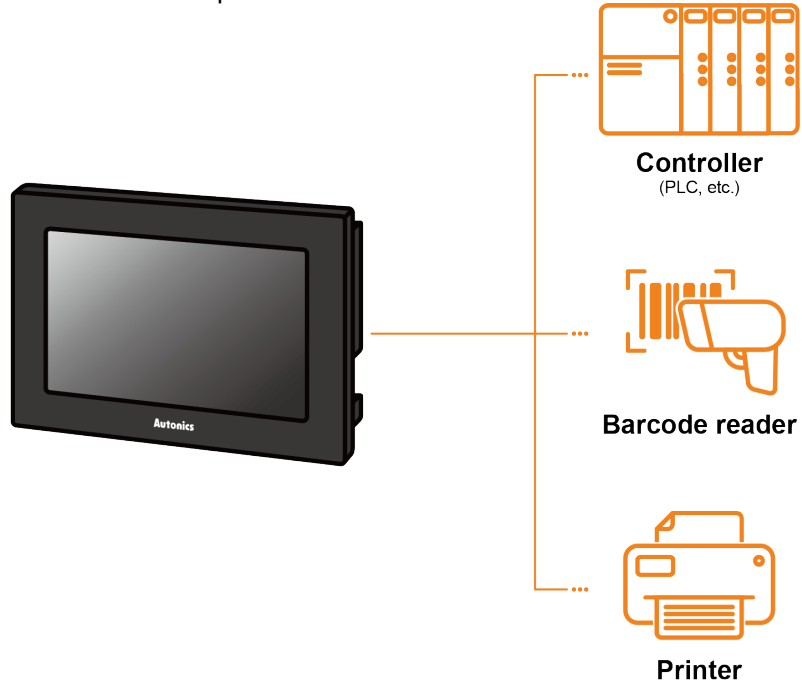

1.1 1:1 Communication

A GP/LP can communicate with a single controller A.

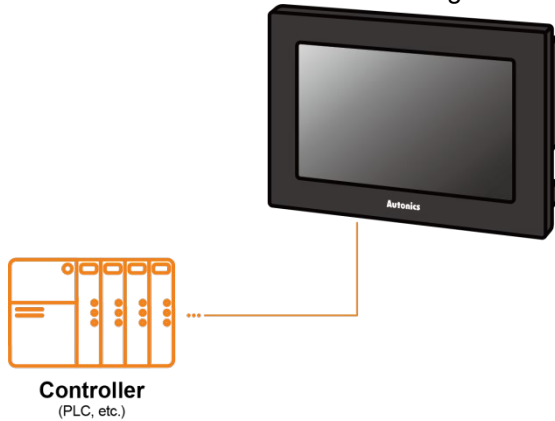

(1) Communication configuration by GP/LP model

The communication configuration by GP/LP model is listed below.

For detailed information about the communication configuration, please refer to 'GP/LP User Manual'.

- GP/LP-S Series

| Series | Chanel | Connecting port | Description |
|------------------------|--------|-----------------|---|
| GP/LP-S044, GP-S057 | CH1 | RS232C/RS422 | Direct communication available |
| | CH2 | RS422/RS485 | Link device ^{※1} communication available |
| GP/LP-S070 | CH1 | RS232C/RS422 | Direct communication available Link device ^{※1} communication available |
| | CH2 | RS422/RS485 | Direct communication available Link device ^{※1} communication available |

- GP/LP-A Series

| Series | Connecting port | Description |
|------------|--|---|
| GP/LP-A070 | RS422 or RS232C-A port, RS232C or RS232C-B port, Ethernet port | Direct communication available Link device ^{※1} communication available |
| GP/LP-A104 | RS422 or RS232C-A port, RS232C or RS232C-B port, Ethernet port, CAN ^{※2} port | Direct communication available Link device ^{※1} communication available |

※1: Please refer to 'GP Editor User Manual' for Link device instruction.

※2: Only Autonics' ARD Series can be connected to CAN port.

1.2 1:N Communication of Same Controllers

1:N communication stands for one LP communicating with multiple of controllers. The GP/LP observes the connected controllers or relays data between controllers. A GP/LP can communicate with the multiple of controller As. The controller has to be able to set address of each device, and the address should not be duplicated.

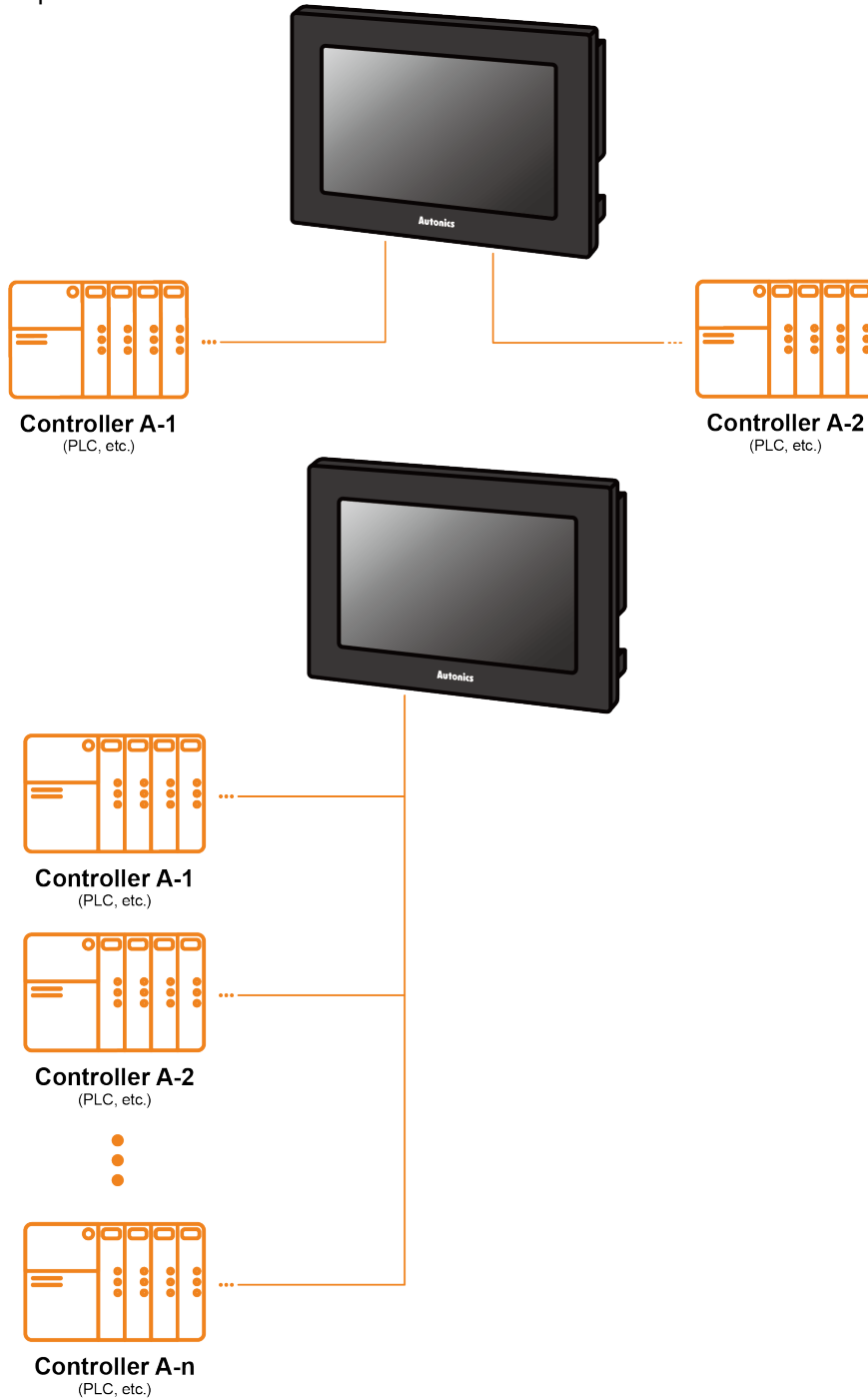

(1) Communication configuration by GP/LP model

The communication configuration by GP/LP model is listed below. For detailed information about the communication configuration, please refer to 'GP/LP User Manual'.

- GP/LP-S Series

| Series | Chanel | Connecting port | Description |
|------------------------|---------------|-----------------|---|
| GP/LP-S044, GP-S057 | CH1 | - | Multiple connection unavailable |
| | CH2 | RS422 | Link device ^{※1} communication available |
| GP/LP-S070 | CH1 or CH2 | RS422 | Direct communication available Link device ^{※1} communication available |

- GP/LP-A Series

| Series | Connecting port | Description |
|------------|--|---|
| GP/LP-A070 | RS422 or RS232C-A port, RS232C or RS232C-B port, Ethernet port | Direct communication available Link device ^{※1} communication available |
| GP/LP-A104 | RS422 or RS232C-A port, RS232C or RS232C-B port, Ethernet port, CAN ^{※2} port | Direct communication available Link device ^{※1} communication available |

※1: Please refer to 'GP Editor User Manual' for Link device instruction.

※2: Only Autonics' ARD Series can be connected to CAN port.

(2) RS422 communication connection diagram

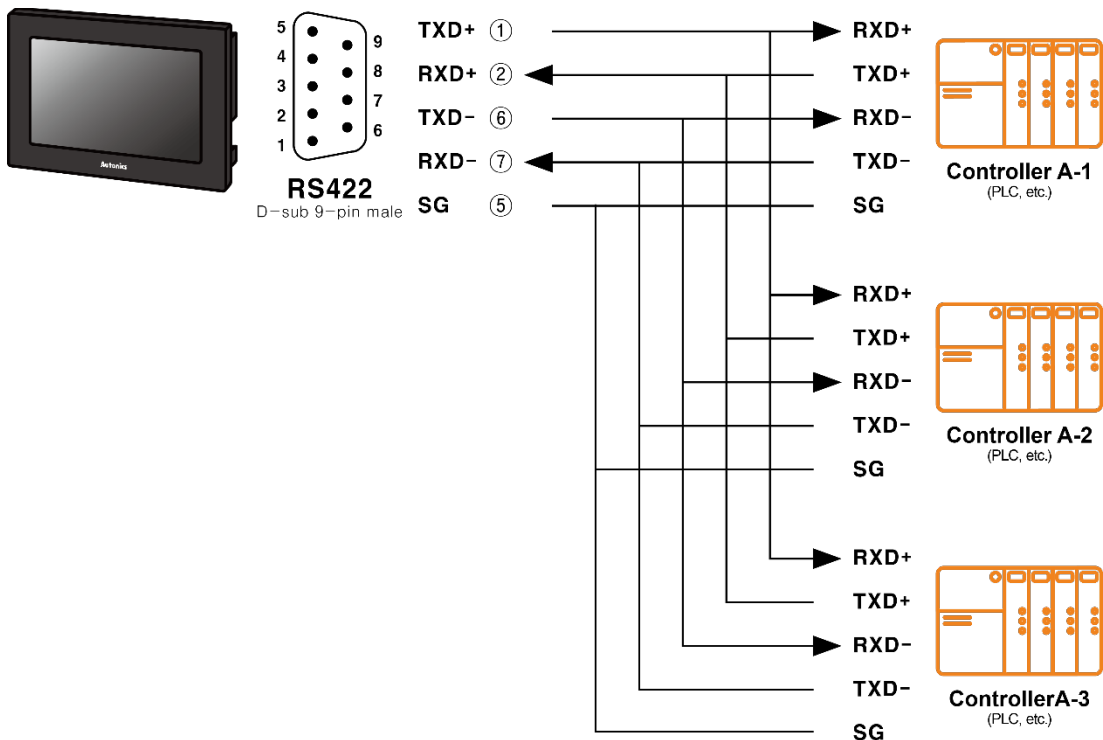

1.3 1:N Communication of Different Controllers

1:N communication stands for one GP/LP communicating with multiple of controllers. The GP/LP observes the connected controllers or relays data between controllers. The GP/LP can communicate with the multiple of different controllers.

1.3.1 1:1:1 Communication

A GP/LP can communicate with a single controller A and a single controller B. The GP/LP relays communications between the controller A and B.



(1) Communication configuration by GP/LP model

The communication configuration by GP/LP model is listed below.

For detailed information about the communication configuration, please refer to 'GP/LP User Manual'.

- GP/LP-S Series

| Series | Chanel | Connecting port | Description |
|------------------------|------------------|-----------------|---|
| GP/LP-S044, GP-S057 | CH1 | RS232C/RS422 | Direct communication available |
| | CH2 | RS422/RS485 | Link device*1 communication available |
| GP/LP-S070 | CH1 or CH2 | RS422/RS485 | Direct communication available Link device*1 communication available |

- GP/LP-A Series

| Series | Connecting port | Description |
|------------|--|---|
| GP/LP-A070 | RS422 or RS232C-A port, RS232C or RS232C-B port, Ethernet port | Direct communication available Link device*1 communication available |
| GP/LP-A104 | RS422 or RS232C-A port, RS232C or RS232C-B port, Ethernet port, CAN*2 port | Direct communication available Link device*1 communication available |

※1: Please refer to 'GP Editor User Manual' for Link device instruction.

※2: Only Autonics' ARD Series can be connected to CAN*2 port.

1.3.2 1:1:N Communication

A GP/LP can communicate with a single controller A and the multiple of controller Bs..
 The GP/LP relays communication between the controller A and B.
 The controller has to be able to set address of each device, and the address should not be duplicated.

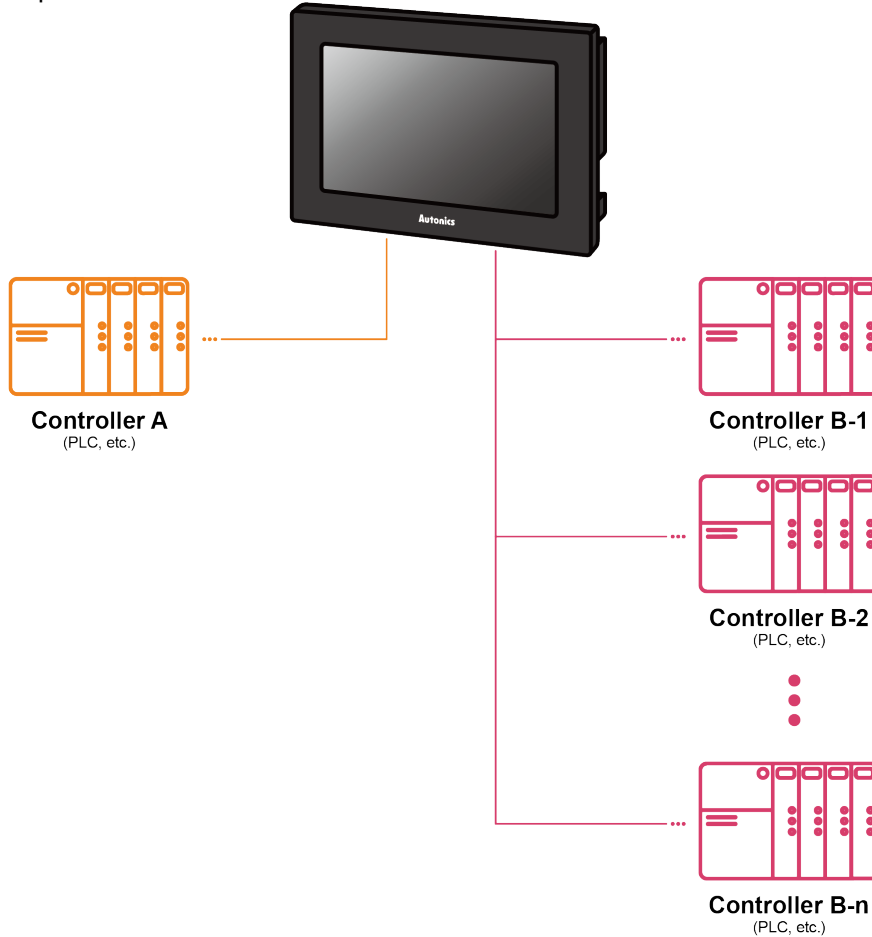

(1) Communication configuration by GP/LP model

The communication configuration by GP/LP model is listed below.
 For detailed information about the communication configuration, please refer to 'GP/LP User Manual'.

- GP/LP-S Series

| Series | Chanel | Connecting port | Description |
|------------------------|---------------|-----------------|---|
| GP/LP-S044, GP-S057 | CH1 | RS232C | Single direct communication available |
| | CH2 | RS422/RS485 | Link device ^{※1} multiple communication available |
| GP/LP-S070 | CH1 or CH2 | RS232C | Single direct communication available Link device ^{※1} single communication available |
| | | RS422/RS485 | Multiple direct communication available Link device ^{※1} multiple communication available |

- GP/LP-A Series

| Series | Connecting port | Description |
|------------|--|---|
| GP/LP-A070 | RS422 or RS232C-A port, RS232C or RS232C-B port, Ethernet port | Direct communication available Link device*1 communication available |
| GP/LP-A104 | RS422 or RS232C-A port, RS232C or RS232C-B port, Ethernet port, CAN*2 port | Direct communication available Link device*1 communication available |

※1: Please refer to 'GP Editor User Manual' for Link device instruction.

※2: Only Autonics' ARD Series can be connected to CAN port.

(2) RS422 communication connection diagram

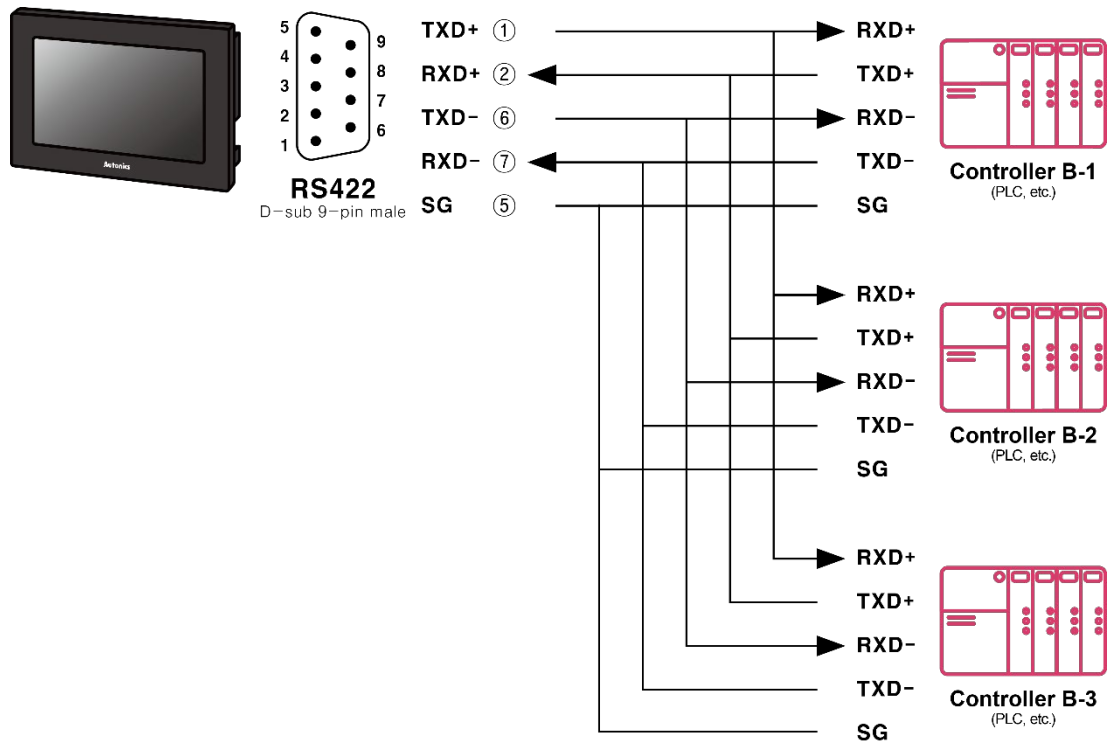

1.3.3 N:1:N Communication

A GP/LP can communicate with the multiple of controller As and Bs. The LP relays communication between the controller A and B.

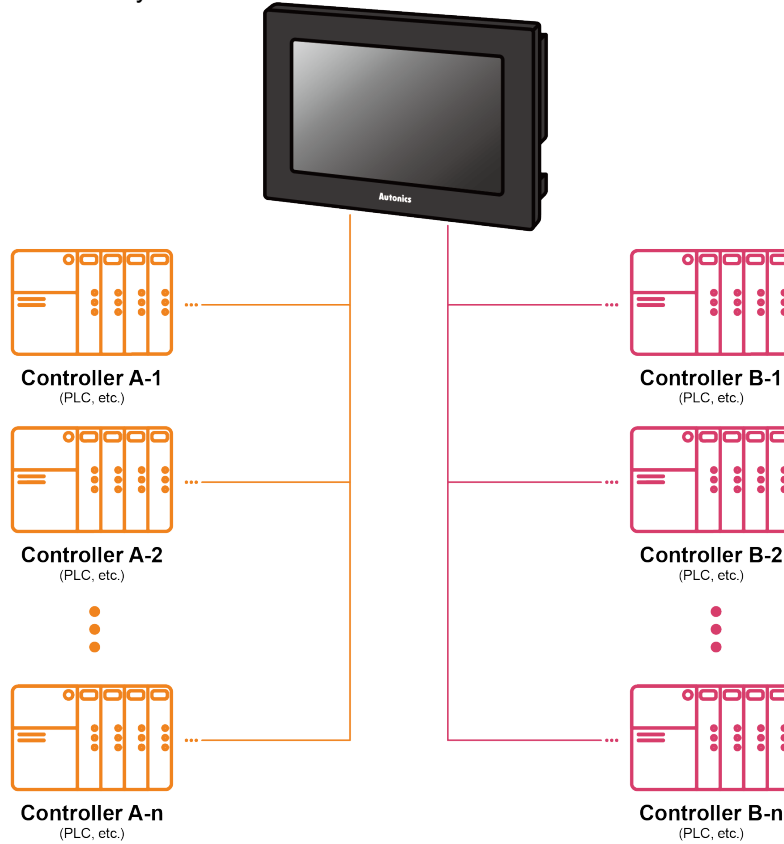

(1) Communication configuration by GP/LP model

The communication configuration by GP/LP model is listed below. For detailed information about the communication configuration, please refer to 'GP/LP User Manual'.

- GP/LP-S Series

| Series | Chanel | Connecting port | Description |
|------------|------------|-----------------|---|
| GP/LP-S070 | CH1 or CH2 | RS232C/RS422 | Multiple direct communication available Link device ^{※1} multiple communication available |

- GP/LP-A Series

| Series | Connecting port | Description |
|------------|--|---|
| GP/LP-A070 | RS422 or RS232C-A port, RS232C or RS232C-B port, Ethernet port | Direct communication available Link device ^{※1} communication available |
| GP/LP-A104 | RS422 or RS232C-A port, RS232C or RS232C-B port, Ethernet port, CAN ^{※2} port | Direct communication available Link device ^{※1} communication available |

※1: Please refer to 'GP Editor User Manual' for Link device instruction.

※2: Only Autonics' ARD Series can be connected to CAN port.

1.4 Barcode Reader, Printer Communication

A GP/LP can communicate with the barcode reader and printer.
 Connect the barcode reader to utilize the barcode data.
 Connect the printer to print the alarm log or the screen.

- GP/LP-S Series: printing alarm log
- GP/LP-A Series: print alarm log and screen

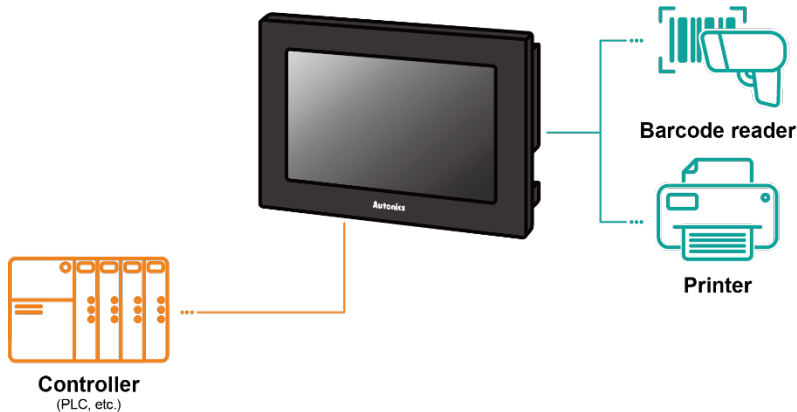

1.4.1 Communication Configuration

1.4.1.1 Barcode Reader

(1) Connected communication port

- GP/LP-S Series

| Series | Connected device | Communication port | | |
|------------------------|------------------|--------------------|--------|----------|
| | | RS232C* | RS422* | USB Host |
| GP/LP-S044, GP-S057 | Controller | ○ | ○ | - |
| | Barcode reader | ○ | ○ | - |
| GP/LP-S070 | Controller | ○ | ○ | - |
| | Barcode reader | ○ | ○ | - |

- GP/LP-A Series

| Series | Connected device | Communication port | | |
|--------------------------|------------------|--------------------|--------|----------|
| | | RS232C* | RS422* | USB Host |
| GP/LP-A070 GP/LP-A104 | Controller | ○ | ○ | - |
| | Barcode reader | ○ | ○ | ○ |

※RS232C/422 converter allows to opposite communication.

(2) Configuration method

1st Set the items related to the use of bar codes in the project in the drawing program, GP Editor/atDesigner.

| Series | Description | Drawing program menu |
|---------|---|--|
| GP/LP-S | Device setting for data storage | Common > Barcode |
| | System device setting for action control | Common > System Information > System Signal 1 |
| GP/LP-A | Device setting for connection port/data storage | Project > Project Property > Special Device Setting |

※For detailed information about system device setting, please refer to 'GP Editor/atDesigner User Manual'.

2nd Download the set project in the drawing program , GP Editor/atDesigner, to GP/LP device.

3rd Make communication settings for each port in the GP/LP system menu.

※For detailed information about communication setting, please refer to 'GP/LP User Manual'.

(3) Communication specification

| Item | Specification |
|--------------|--|
| Baud rate | 300, 600, 1200, 3200, 4800, 9600, 19200, 38400, 57600, 115200bps |
| Data length | 7, 8 bit |
| Parity | None, Odd, Even |
| Stop bit | 1, 2 bit |
| Flow control | DSR/DTR, XON/XOFF |

1.4.1.2 Printer**(1) Connected communication port**

- GP/LP-S Series

| Series | Connected device | Communication port | | |
|------------------------|------------------|--------------------|--------|----------|
| | | RS232C※ | RS422※ | USB Host |
| GP/LP-S044, GP-S057 | Controller | ○ | ○ | - |
| | Printer | ○ | ○ | - |
| GP/LP-S070 | Controller | ○ | ○ | - |
| | Printer | ○ | ○ | - |

- GP/LP-A Series

| Series | Connected device | Communication port | | |
|---------------------------|------------------|--------------------|--------|----------|
| | | RS232C※ | RS422※ | USB Host |
| GP/LP-A070, GP/LP-A104 | Controller | ○ | ○ | - |
| | Printer | - | - | ○ |

(2) Configuration method

1st Set screen printing/alarm log printing device and touch key/switch in drawing program, GP Editor/atDesigner.

| Series | Description | Drawing program menu |
|---------|--|---|
| GP/LP-S | System device setting for action control | Common > System Information > System Signal |
| GP/LP-A | Device setting for screen print control | Project window > Right-click menu of the screen to print > Screen Printer Setting |
| | Device setting for alarm log print | Project window > Alarm History > Use Print |

2nd Download the set project in the drawing program , GP Editor/atDesigner, to GP/LP device.

3rd Make communication settings for each port in the GP/LP system menu.

※ For detailed information about communication setting, please refer to 'GP/LP User Manual'.

(3) Communication specification

| Item | Specification |
|--------------|---|
| Baud rate | 300, 600, 1200, 3200, 4800, 9600, 19200, 38400, 57600 bps |
| Data length | 7, 8 bit |
| Parity | None, Odd, Even |
| Stop bit | 1, 2 bit |
| Flow control | DSR/DTR, XON/XOFF |

2 Communication Configuration by Devices

2.1 Autonics Product

GP/LP can be communicated with Autonics's products such as Multi Temperature Controllers (TK/TM/TMH/TZ Series), Temperature/Humidity Transducer (THD-RT Series), Counter/Timer (CT Series), Panel Meter (MT Series), Pulse Meter (MP Series), Display Unit (DS/DA Series), Digital Remote I/O (ARM/ARD Series).

2.1.1 Connection Support Products

| PLC type | | Communication method | Default baud rate (bps) |
|----------------|-----------------------|-----------------------------|-------------------------|
| Autonics | TK(MODBUS) | RS485/422 | 9600 |
| | TM(MODBUS) | | |
| | TMH2/4/C_22LE(MODBUS) | | |
| | TZ | | |
| | THD-RT(MODBUS) | | |
| | CT(MODBUS) | | |
| | MT | | |
| | MT(MODBUS) | | |
| | MP | | |
| | DS/DA(MODBUS) | | |
| | ARM(MODBUS) | | |
| ARD(DeviceNet) | DeviceNet | Automatically set as Master | |

2.1.2 Connectable GP/LP Model

| Connected devices | Connection method | GP/LP Model | | | | | | | | |
|-------------------|-------------------|-----------------------|----------------------|---------|------------|------------|--------------|-----------------|-----------------|----------------|
| | | GP-2480 (under V2.70) | GP-2480 (over V3.00) | GP-S057 | GP/LP-S044 | GP/LP-S070 | GP-S057 (V2) | GP/LP-S044 (V2) | GP/LP-S070 (V2) | GP/LP-A Series |
| TK Series | Modbus | x | ○ | ○ | ○ | x | x | x | x | x |
| | Modbus (TYPE A) | x | x | ○ | ○ | ○ | ○ | ○ | ○ | ○ |
| TM Series | Modbus | x | ○ | ○ | ○ | x | x | x | x | x |
| | Modbus (TYPE A) | x | x | ○ | ○ | ○ | ○ | ○ | ○ | ○ |
| TMH Series | Modbus (TYPE A) | x | x | x | x | x | ○ | ○ | ○ | ○ |
| TZ Series | Dedicated comm. | ○ | ○ | ○ | ○ | ○ | ○ | ○ | ○ | ○ |
| THD Series | Modbus | ○ | ○ | ○ | ○ | x | x | x | x | x |
| | Modbus (TYPE A) | x | x | ○ | ○ | ○ | ○ | ○ | ○ | ○ |
| CT Series | Modbus | x | ○ | ○ | ○ | x | x | x | x | x |
| | Modbus (TYPE A) | x | x | ○ | ○ | ○ | ○ | ○ | ○ | ○ |
| MT Series | Dedicated comm. | ○ | ○ | ○ | ○ | ○ | ○ | ○ | ○ | ○ |
| | Modbus | x | ○ | ○ | ○ | x | x | x | x | x |

| Connected devices | Connection method | GP/LP Model | | | | | | | | |
|-------------------|-------------------|-----------------------|----------------------|---------|------------|------------|--------------|-----------------|-----------------|----------------|
| | | GP-2480 (under V2.70) | GP-2480 (over V3.00) | GP-S057 | GP/LP-S044 | GP/LP-S070 | GP-S057 (V2) | GP/LP-S044 (V2) | GP/LP-S070 (V2) | GP/LP-A Series |
| | Modbus (TYPE A) | x | x | ○ | ○ | ○ | ○ | ○ | ○ | ○ |
| MP Series | Dedicated comm. | ○ | ○ | ○ | ○ | ○ | ○ | ○ | ○ | ○ |
| DS/DA Series | Modbus (TYPE A) | x | x | ○ | ○ | ○ | ○ | ○ | ○ | ○ |
| ARM Series | Modbus (TYPE A) | x | x | ○ | ○ | ○ | ○ | ○ | ○ | ○ |
| ARD Series | DeviceNet | x | x | x | x | x | x | x | x | ○* |

※ Only Autonics' ARD Series can be connected to CAN port.

2.1.3 System Organization

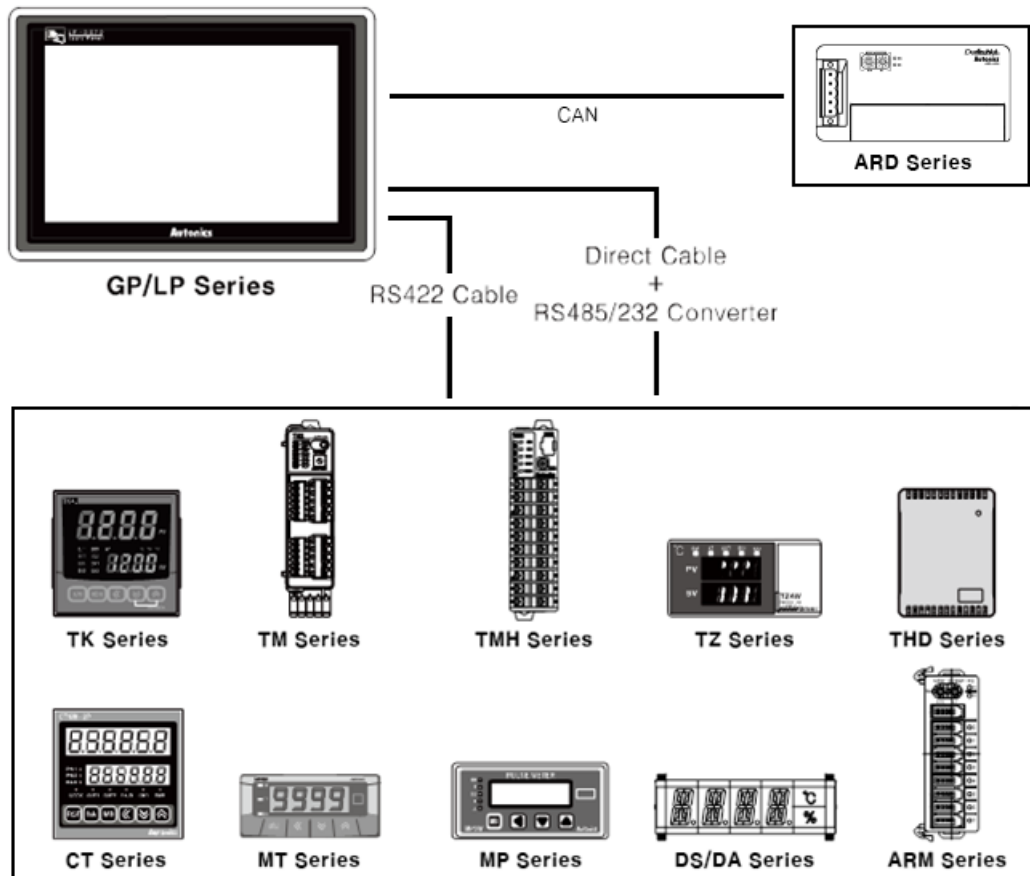

Autonics's TK, TM, TMH, TZ, THD-RT, CT, MT, MP, DS/DA, ARM products communicate RS485 as default during cable connection as follows;

Also RS232C communication is available by using RS485/232 converter.

ARD Series can be connected with GP/LP-A104 with CAN communication.



Note

Autonics controller's communication speed, address, and GP/LP's communication speed, address must be set the same. For the detailed informations about communication and address setting for each product, please refer to user manual for corresponding products.
 Since Autonics controllers are classified as Read/Write devices, so take care during use. Especially using as CH2, please refer to '1 System Organization'.

2.1.4 Communication Cable

(1) RS485

- Applied cable: C3M5P03-D9M0-W4*0

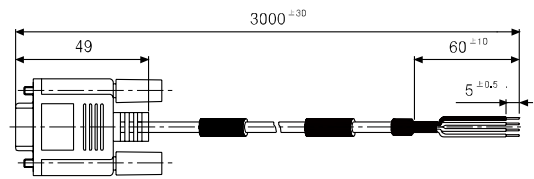
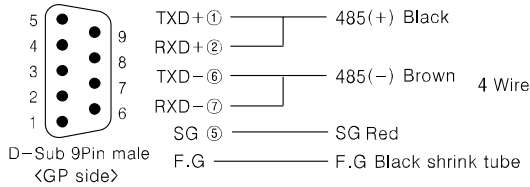

- Applied cable: C3M5P03-D9M0-T4Y0

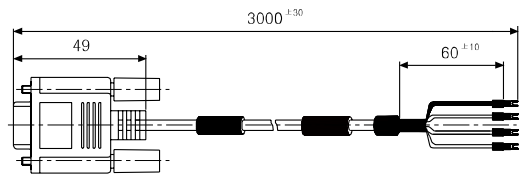

(2) RS422

- Applied cable: C3M5P04-D9M0-T6Y0

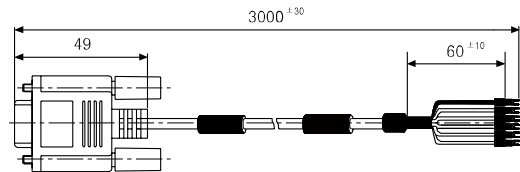
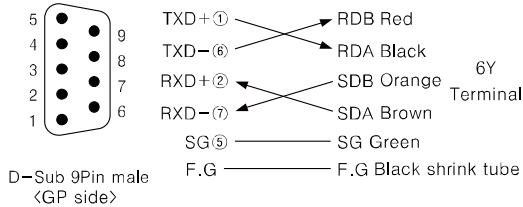

(3) CAN

Please wire as follows.

| No. | Color | Use | Arrangement |
|-----|-------|----------|-------------|
| 1 | Black | 24VDC(-) | |
| 2 | Blue | CAN_L | |
| 3 | None | SHIELD | |
| 4 | White | CAN_H | |
| 5 | Red | 24VDC(+) | |

2.1.5 Available Device

2.1.5.1 TK

Please refer to 'TK communication manual' for Autonics TK's available devices

(1) Modbus (TK_Mod)

| Type | Device | Mark | Range | |
|------|------------------|------|--------------------------|-----|
| | | | Start | End |
| Bit | Bit device area | TK | Refer to TK device table | |
| Word | Word device area | TK | Refer to TK device table | |

(2) Modbus TYPE A (TK_Mod_A)

| Type | Device | Name | Range | |
|------|------------------|------|--------------------------|-----|
| | | | Start | End |
| Bit | Bit device area | 0 | Refer to TK device table | |
| | Bit device area | 1 | Refer to TK device table | |
| Word | Word device area | 3 | Refer to TK device table | |
| | Word device area | 4 | Refer to TK device table | |

2.1.5.2 TM

Please refer to 'TM communication manual' for Autonics TM's available devices

(1) Modbus (TM_Mod)

| Type | Device | Name | Range | |
|------|------------------|------|--------------------------|-----|
| | | | Start | End |
| Bit | Bit device area | TM | Refer to TM device table | |
| Word | Word device area | TM | Refer to TM device table | |

(2) Modbus TYPE A(TM_Mod_A)

| Type | Device | Name | Range | |
|------|------------------|------|--------------------------|-----|
| | | | Start | End |
| Bit | Bit device area | 0 | Refer to TM device table | |
| | Bit device area | 1 | Refer to TM device table | |
| Word | Word device area | 3 | Refer to TM device table | |
| | Word device area | 4 | Refer to TM device table | |

2.1.5.3 TMH

Please refer to 'TMH communication manual' for Autonics TMH's available devices

(1) TMH2

| Type | Device | Name | Range | |
|--------|------------------|--------|------------------|------------------|
| | | | Start | End |
| Bit | Bit device area | 0 | 000001 | 000002 |
| | Bit device area | 1 | 100001 100005 | 100002 100008 |
| Word | Word device area | 3 | 300101 | 300114 |
| | | | 300118 | 300126 |
| | | | 301001 | 301002 |
| | | | 301005 | 301006 |
| | | | 301009 | 301010 |
| | | | 301013 | 301014 |
| | | | 301017 | 301018 |
| | 301021 | 301022 | | |
| | 301025 | 301031 | | |
| | Word device area | 4 | 400001 | 400004 |
| | | | 400051 | 400056 |
| | | | 400101 | 400132 |
| | | | 400151 | 400169 |
| | | | 400201 | 400206 |
| 400251 | | | 400303 | |
| 400351 | | | 400359 | |
| 400401 | 400410 | | | |

(2) TMH4

| Type | Device | Name | Range | |
|--------|------------------|------|------------------|------------------|
| | | | Start | End |
| Bit | Bit device area | 0 | 000001 | 000008 |
| | Bit device area | 1 | 100001 100011 | 100004 100026 |
| Word | Word device area | 3 | 300101 | 300114 |
| | | | 300118 | 300126 |
| | | | 301001 | 301031 |
| | Word device area | 4 | 400001 | 400004 |
| | | | 400051 | 400056 |
| | | | 400101 | 400132 |
| | | | 400151 | 400169 |
| | | | 400201 | 400206 |
| | | | 400251 | 400303 |
| | | | 400351 | 400359 |
| 400401 | 400410 | | | |

(3) TMHC-22LE

| Type | Device | Name | Range | |
|------|------------------|------|--------|--------|
| | | | Start | End |
| Word | Word device area | 3 | 300083 | 300088 |
| | | | 300101 | 300114 |
| | | | 300118 | 300126 |
| | Word device area | 4 | 400301 | 400311 |
| | | | 400401 | 400458 |

2.1.5.4 TZ

Autonics TZ's available devices and parameters can be represented as follows: Only TZ exists for the available device.

| Type | Device | Name | Range | |
|------|------------------|------|-------|-----|
| | | | Start | End |
| Word | Word device area | TZ | TZ0 | TZ1 |

| Device | Description | Read/Write |
|--------|---------------|------------|
| TZ0 | Current value | Read |
| TZ1 | Set value | Read/Write |

2.1.5.5 THD-RT(Modbus)

Autonics THD-RT's available devices and parameters can be represented as follows: Only TH exists for the available device. Modbus (THD-RT_Mod)

| Type | Device | Name | Range | |
|------|------------------|------|---------|---------|
| | | | Start | End |
| Word | Word device area | TH | TH30001 | TH30002 |
| | Word device area | TH | TH30101 | TH30125 |

| Device | Description | Read/Write |
|---------|---------------------------|------------|
| TH30001 | Temperature value | Read |
| TH30002 | Humidity value | Read |
| ... | Blank | - |
| TH30101 | Product number H | Read |
| TH30102 | Product number L | Read |
| TH30103 | Hardware version | Read |
| TH30104 | Software version | Read |
| TH30105 | Model name 1 | Read |
| TH30106 | Model name 2 | Read |
| TH30107 | Model name 3 | Read |
| TH30108 | Model name 4 | Read |
| TH30109 | Model name 5 | Read |
| TH30110 | Model name 6 | Read |
| TH30111 | Model name 7 | Read |
| TH30112 | Model name 8 | Read |
| TH30113 | Model name 9 | Read |
| TH30114 | Model name 10 | Read |
| TH30115 | Reserved area | Read |
| TH30116 | Reserved area | Read |
| TH30117 | Reserved area | Read |
| TH30118 | Coil start address | Read |
| TH30119 | Coil quantity | Read |
| TH30120 | Input start address | Read |
| TH30121 | Input quantity | Read |
| TH30122 | Holding REG start address | Read |

| Device | Description | Read/Write |
|---------|-------------------------|------------|
| TH30123 | Holding REG quantity | Read |
| TH30124 | Input REG start address | Read |
| TH30125 | Input REG quantity | Read |

(4) Modbus TYPE A(THD-RT_Mod_A)

| Type | Device | Name | Range | |
|------|------------------|------|--------|--------|
| | | | Start | End |
| Word | Word device area | 3 | 300001 | 300002 |
| | Word device area | 3 | 300101 | 300125 |

| Device | Description | Read/Write |
|--------|---------------------------|------------|
| 300001 | Temperature value | Read |
| 300002 | Humidity value | Read |
| ... | Blank | - |
| 300101 | Product number H | Read |
| 300102 | Product number L | Read |
| 300103 | Hardware version | Read |
| 300104 | Software version | Read |
| 300105 | Model name 1 | Read |
| 300106 | Model name 2 | Read |
| 300107 | Model name 3 | Read |
| 300108 | Model name 4 | Read |
| 300109 | Model name 5 | Read |
| 300110 | Model name 6 | Read |
| 300111 | Model name 7 | Read |
| 300112 | Model name 8 | Read |
| 300113 | Model name 9 | Read |
| 300114 | Model name 10 | Read |
| 300115 | Reserved area | Read |
| 300116 | Reserved area | Read |
| 300117 | Reserved area | Read |
| 300118 | Coil start address | Read |
| 300119 | Coil quantity | Read |
| 300120 | Input start address | Read |
| 300121 | Input quantity | Read |
| 300122 | Holding REG start address | Read |
| 300123 | Holding REG quantity | Read |
| 300124 | Input REG start address | Read |
| 300125 | Input REG quantity | Read |

2.1.5.6 CT

Please refer to 'CT communication manual' for Autonics CT's available devices

(1) Modbus (CT_Mod)

| Type | Device | Name | Range | |
|------|------------------|------|--------------------------|-----|
| | | | Start | End |
| Bit | Bit device area | CT | Refer to CT device table | |
| Word | Word device area | CT | Refer to CT device table | |

(2) Modbus TYPE A(CT_Mod_A)

| Type | Device | Name | Range | |
|------|------------------|------|--------------------------|-----|
| | | | Start | End |
| Bit | Bit device area | 0 | Refer to CT device table | |
| | Bit device area | 1 | Refer to CT device table | |
| Word | Word device area | 3 | Refer to CT device table | |
| | Word device area | 4 | Refer to CT device table | |

2.1.5.7 MT Series

Autonics MT's available devices and parameters can be represented as follows: Only MT exists for the available device.

(1) In case of MT Series, not ModBus communication type

| Type | Device | Name | Range | |
|------|------------------|------|-------|-----|
| | | | Start | End |
| Word | Word device area | MT | MT0 | MT0 |

| Device | Description | Read/Write |
|--------|---------------|------------|
| MT0 | Current value | Read |

(2) In case of MT Series with ModBus communication type (MT4N)

1) Modbus (MT4N_Mod)

| Type | Device | Name | Range | |
|------|------------------|------|---------|---------|
| | | | Start | End |
| Bit | Bit device area | MT | MT10001 | MT10001 |
| Word | Word device area | MT | MT30001 | MT30004 |
| | Word device area | MT | MT30101 | MT30109 |
| | Word device area | MT | MT30118 | MT30125 |

| Device | Description | Read/Write |
|---------|---------------------------|------------|
| MT30001 | Current value | Read |
| MT30002 | Dot setting value | Read |
| MT30003 | Max. signal input | Read |
| MT30004 | Min. signal input | Read |
| MT30101 | Product number H | Read |
| MT30102 | Product number L | Read |
| MT30103 | Hardware version | Read |
| MT30104 | Software version | Read |
| MT30105 | Model name 1 | Read |
| MT30106 | Model name 2 | Read |
| MT30107 | Model name 3 | Read |
| MT30108 | Model name 4 | Read |
| MT30109 | Model name 5 | Read |
| MT30118 | Coil start address | Read |
| MT30119 | Coil quantity | Read |
| MT30120 | Input start address | Read |
| MT30121 | Input quantity | Read |
| MT30122 | Holding REG start address | Read |
| MT30123 | Holding REG quantity | Read |
| MT30124 | Input REG start address | Read |
| MT30125 | Input REG quantity | Read |

2) Modbus TYPE A (MT4N_Mod_A)

| Type | Device | Name | Range | |
|------|------------------|------|--------|--------|
| | | | Start | End |
| Bit | Bit device area | 1 | 100001 | 100001 |
| Word | Word device area | 3 | 300001 | 300004 |
| | Word device area | 3 | 300101 | 300109 |
| | Word device area | 3 | 300118 | 300125 |

| Device | Description | Read/Write |
|--------|-------------------|------------|
| 300001 | Current value | Read |
| 300002 | Dot setting value | Read |
| 300003 | Max. signal input | Read |
| 300004 | Min. signal input | Read |
| 300101 | Product number H | Read |

| Device | Description | Read/Write |
|--------|---------------------------|------------|
| 300102 | Product number L | Read |
| 300103 | Hardware version | Read |
| 300104 | Software version | Read |
| 300105 | Model name 1 | Read |
| 300106 | Model name 2 | Read |
| 300107 | Model name 3 | Read |
| 300108 | Model name 4 | Read |
| 300109 | Model name 5 | Read |
| 300118 | Coil start address | Read |
| 300119 | Coil quantity | Read |
| 300120 | Input start address | Read |
| 300121 | Input quantity | Read |
| 300122 | Holding REG start address | Read |
| 300123 | Holding REG quantity | Read |
| 300124 | Input REG start address | Read |
| 300125 | Input REG quantity | Read |

(3) In case of MT Series with ModBus type (MT4W, MT4Y)

- 1) Modbus (MT4W_Mod, MT4Y_Mod)

| Type | Device | Name | Range | |
|------|------------------|------|---------|---------|
| | | | Start | End |
| Bit | Bit device area | MT | MT10001 | MT10001 |
| Word | Word device area | MT | MT30001 | MT30004 |

| Device | Description | Read/Write |
|---------|-------------------|------------|
| MT30001 | Current value | Read |
| MT30002 | Dot setting value | Read |
| MT30003 | Max. signal input | Read |
| MT30004 | Min. signal input | Read |

- 2) Modbus TYPE A (MT4W_Mod_A., MT4Y_Mod_A)

| Type | Device | Name | Range | |
|------|------------------|------|--------|--------|
| | | | Start | End |
| Bit | Bit device area | 1 | 100001 | 100001 |
| Word | Word device area | 3 | 300001 | 300004 |

| Device | Description | Read/Write |
|--------|-------------------|------------|
| 300001 | Current value | Read |
| 300002 | Dot setting value | Read |
| 300003 | Max. signal input | Read |
| 300004 | Min. signal input | Read |

2.1.5.8 MP

Autonics MP's available devices and parameters can be represented as follows: Only MP exists for the available device.

| Type | Device | Name | Range | |
|------|-------------------------|------|-------|------|
| | | | Start | End |
| Word | Word device area(32Bit) | MP | MP0 | MP11 |

| Device | Code | Description | Read/Write |
|--------|------|---------------------------|------------|
| MP0 | P0 | Current value | Read |
| MP1 | C0 | Compare setting value(HH) | Read/Write |
| MP2 | C1 | Compare setting value(H) | Read/Write |
| MP3 | C2 | Compare setting | Read/Write |

| Device | Code | Description | Read/Write |
|--------|------|---------------------------|------------|
| | | value(L) | |
| MP4 | C3 | Compare setting value(LL) | Read/Write |
| MP5 | K0 | Peak value (max) | Read |
| MP6 | K1 | Peak value (min) | Read |
| MP7 | X0 | Prescale value X.Ain | Read/Write |
| MP8 | X1 | Prescale value X.Bin | Read/Write |
| MP9 | Y0 | Prescale value Y.Ain | Read/Write |
| MP10 | Y1 | Prescale value Y.Bin | Read/Write |
| MP11 | R0 | Max/min value reset | Write |



Note

The MP device must be downloaded with the data format set to 32 bits in the setting of numerical display / numeric input / ASCII input / ASCII display of GP Editor, and accurate parameter value and read / write can be performed.

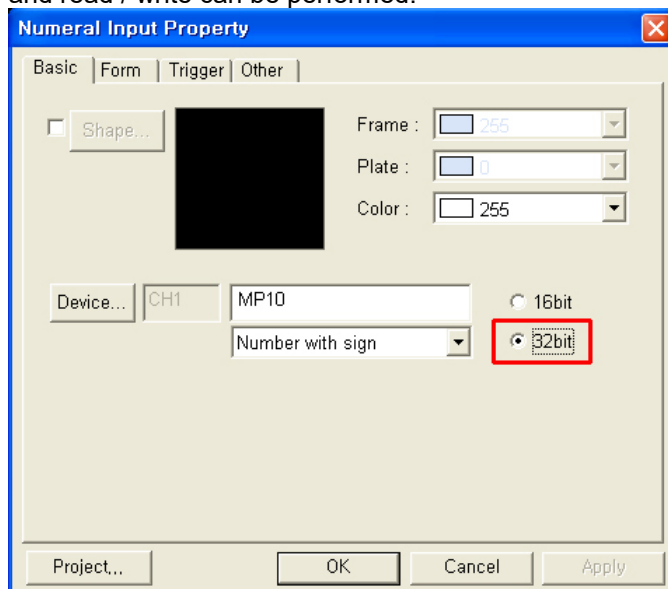

2.1.5.9 DS/DA

Please refer to 'DS/DA instruction manual' for Autonics Display Unit DS/DA Series's available devices

| Type | Device | Name | Range | |
|------|------------------|------|-----------------------------|-----|
| | | | Start | End |
| Word | Word device area | 3 | Refer to DS/DA device table | |
| | Word device area | 4 | Refer to DS/DA device table | |

2.1.5.10 ARM

Please refer to 'ARM communication manual' for Autonics ARM Series's available devices

| Type | Device | Name | Range | |
|------|------------------|------|---------------------------|-----|
| | | | Start | End |
| Bit | Bit device area | 0 | Refer to ARM device table | |
| | Bit device area | 1 | Refer to ARM device table | |
| Word | Word device area | 3 | Refer to ARM device table | |
| | Word device area | 4 | Refer to ARM device table | |

2.1.6 Monitorable Device in GP/LP

The status can be changed by monitoring the connected devices in GP/LP.

The following is a list of devices available in this menu, please refer to 'Available devices' for available device range.

2.1.6.1 TK Series

(1) Modbus

| Type | Mark | Device | Note |
|------|------|------------------|------|
| Bit | TK | Bit device area | |
| Word | TK | Word device area | |

(2) Modbus TYPE A

| Type | Mark | Device | Note |
|------|------|------------------|------|
| Bit | 0 | Bit device area | |
| | 1 | Bit device area | |
| Word | 3 | Word device area | |
| | 4 | Word device area | |

2.1.6.2 TM Series

(1) Modbus

| Type | Mark | Device | Note |
|------|------|------------------|------|
| Bit | TM | Bit device area | |
| Word | TM | Word device area | |

(2) Modbus TYPE A

| Type | Mark | Device | Note |
|------|------|------------------|------|
| Bit | 0 | Bit device area | |
| | 1 | Bit device area | |
| Word | 3 | Word device area | |
| | 4 | Word device area | |

2.1.6.3 TMH Series

Same as 'Available devices'.

2.1.6.4 TZ Series

| Type | Mark | Device | Note |
|------|------|---------------|------|
| Word | TZ | Data register | |

2.1.6.5 THD-RT(MOD)

(1) Modbus

| Type | Mark | Device | Note |
|------|------|------------------|------|
| Word | TH | Word device area | |

(2) Modbus TYPE A

| Type | Mark | Device | Note |
|------|------|------------------|------|
| Word | 3 | Word device area | |

2.1.6.6 CT Series**(1) Modbus**

| Type | Mark | Device | Note |
|------|------|------------------|------|
| Bit | CT | Bit device area | |
| Word | CT | Word device area | |

(2) Modbus TYPE A

| Type | Mark | Device | Note |
|------|------|------------------|------|
| Bit | 0 | Bit device area | |
| | 1 | Bit device area | |
| Word | 3 | Word device area | |
| | 4 | Word device area | |

2.1.6.7 MT Series**(1) Modbus**

| Type | Mark | Device | Note |
|------|------|---------------|------|
| Word | MT | Data register | |

(2) Modbus TYPE A

| Type | Mark | Device | Note |
|------|------|------------------|------|
| Bit | 1 | Bit device area | |
| Word | 3 | Word device area | |

2.1.6.8 MP Series

| Type | Mark | Device | Note |
|------|------|---------------|-------|
| Word | MP16 | Data register | 16Bit |
| | MP32 | Data register | 32Bit |

2.1.6.9 DS/DA Series

| Type | Mark | Device | Note |
|------|------|------------------|------|
| Word | 3 | Word device area | |
| | 4 | Word device area | |

2.1.6.10 ARM Series

| Type | Mark | Device | Note |
|------|------|------------------|------|
| Bit | 0 | Bit device area | |
| | 1 | Bit device area | |
| Word | 3 | Word device area | |
| | 4 | Word device area | |

2.2 Connection to Autonics LP Series

GP/LP is able to communicate with Autonics LP Series.

2.2.1 Connection Support Products

| PLC Type | | Comm. method | Communication type | Baud rate (bps) |
|--------------------|--|--------------------|--------------------------------|--------------------------|
| Autonics LP Series | LP-S044 LP-S070 LP-A070 LP-A104 | RS-232C, RS422* | CPU direct connection (Loader) | 300 to 115200 selectable |

*RS 422 communication is available, when using RS 232/422 converter.

2.2.2 Connectable GP/LP Model

| Connected devices | Connection method | GP/LP Model | | | | | | | | |
|-------------------|-------------------|-----------------------|----------------------|---------|------------|------------|--------------|-----------------|-----------------|----------------|
| | | GP-2480 (under V2.70) | GP-2480 (over V3.00) | GP-S057 | GP/LP-S044 | GP/LP-S070 | GP-S057 (V2) | GP/LP-S044 (V2) | GP/LP-S070 (V2) | GP/LP-A Series |
| LP-S044, LP-S070 | CPU | x | ○ | ○ | ○ | ○ | ○ | ○ | ○ | ○ |
| LP-A070, LP-A104 | CPU | x | x | x | x | x | ○ | ○ | ○ | ○ |

2.2.3 System Organization

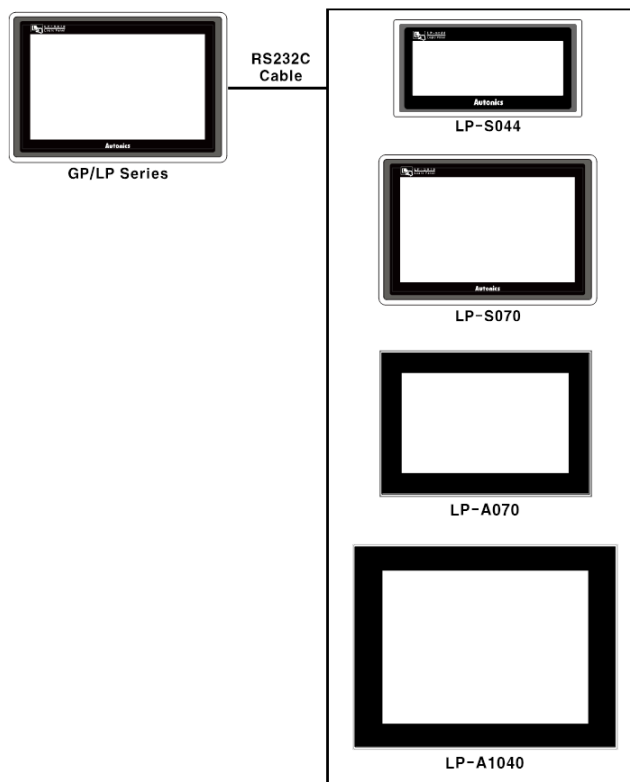

Autonics LP Series performs RS 232C communication as a default.

2.2.4 Communication Cable

(1) RS232C

- Applied cable: C3M5P14-D9F0-D9F0

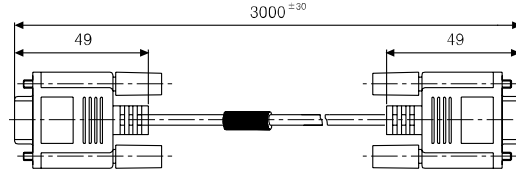
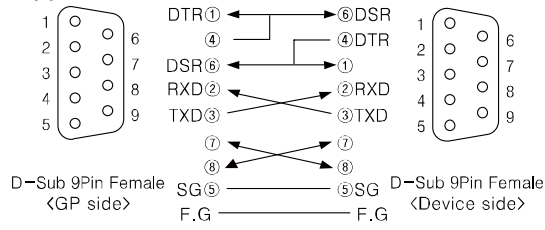

(2) RS422

- Applied cable: C3M5P15-D9M0-D9M0

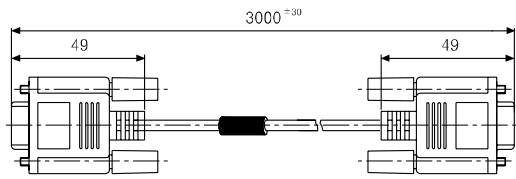
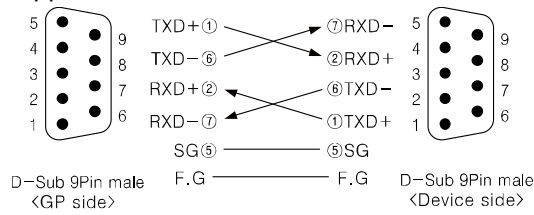

2.2.5 Available Device

The device range differs depending on the PLC model and the number of I/O contacts.

The available PLC model in GP/LP are as follows.

For detailed information about each device, please refer to the manuals provided by each manufacturer and

For detailed information about GP/LP internal device, please refer to 'atLogic Programming Manual'.

2.2.5.1 Device Structure

| | | |
|---|----|---|
| X | 00 | 0 |
|---|----|---|

①Device name

②Word address

③Bit address

| Type | ① | ② | ③ |
|------|---|-----------------------|-------------|
| Bit | X | Decimal | Hexadecimal |
| | Y | Decimal | Hexadecimal |
| | M | Decimal | Hexadecimal |
| | F | Decimal | Hexadecimal |
| | L | Decimal | Hexadecimal |
| | S | Bit address(Decimal) | |
| | T | Bit address(Decimal) | |
| | C | Bit address(Decimal) | |
| Word | X | Word address(Decimal) | none |
| | Y | Word address(Decimal) | none |
| | M | Word address(Decimal) | none |
| | F | Word address(Decimal) | none |
| | L | Word address(Decimal) | none |
| | T | Word address(Decimal) | |
| | C | Word address(Decimal) | |
| | D | Word address(Decimal) | |
| | R | Word address(Decimal) | |



Ex.

Word X1 = Bit X10 to X1F , Word UW10 = UB100 to UB10F

2.2.5.2 Device Range

(1) LP-S044

| Type | Device | Name | Range | |
|---------------|--------------------------------|------|-------|--------|
| | | | Start | End |
| Bit | Input relay | X | X0 | X255F |
| | Output relay | Y | Y0 | Y255F |
| | Internal auxiliary relay | M | M0 | M9999F |
| | Status relay | S | S0 | S25599 |
| | Special relay | F | F0 | F255F |
| | Link relay | L | L0 | L255F |
| | Timer contact [10ms] | T | T0 | T127 |
| | Timer contact [100ms] | T | T128 | T255 |
| | Counter contact [16 bit] | C | C0 | C255 |
| Word | Input register | X | X0 | X255 |
| | Output register | Y | Y0 | Y255 |
| | Internal auxiliary register | M | M0 | M9999 |
| | File register | R | R0 | R3999 |
| | Special register | F | F0 | F255 |
| | Link register | L | L0 | L255 |
| | Timer current value [10ms] | T | T0 | T127 |
| | Timer current value [100ms] | T | T128 | T255 |
| | Counter current value [16 bit] | C | C0 | C255 |
| Data register | D | D0 | D9999 | |

(2) LP-S070

| Type | Device | Name | Range | |
|---------------|--------------------------------|------|-------|---------|
| | | | Start | End |
| Bit | Input relay | X | X0 | X255F |
| | Output relay | Y | Y0 | Y255F |
| | Internal auxiliary relay | M | M0 | M9999F |
| | Status relay | S | S0.00 | S255.99 |
| | Special relay | F | F0 | F300F |
| | Link relay | L | L0 | L255F |
| | Timer contact [10ms] | T | T0 | T127 |
| | Timer contact [100ms] | T | T128 | T255 |
| | Counter contact [16 bit] | C | C0 | C255 |
| Word | Input register | X | X0 | X255 |
| | Output register | Y | Y0 | Y255 |
| | Internal auxiliary register | M | M0 | M9999 |
| | File register | R | R0 | R3999 |
| | Special register | F | F0 | F300 |
| | Link register | L | L0 | L255 |
| | Timer current value [10ms] | T | T0 | T127 |
| | Timer current value [100ms] | T | T128 | T255 |
| | Counter current value [16 bit] | C | C0 | C255 |
| Data register | D | D0 | D9999 | |

(3) LP-A070/A104

| Type | Device | Name | Range | |
|------|--------------------------------|------|-------|---------|
| | | | Start | End |
| Bit | Input relay | X | X0 | X15999F |
| | Output relay | Y | Y0 | Y15999F |
| | Internal auxiliary relay | M | M0 | M14999F |
| | Status relay | S | S0 | S999.99 |
| | Special relay | F | F0 | F299F |
| | Link relay | L | L0 | L999F |
| | Timer contact [10ms] | T | T0 | T127 |
| | Timer contact [100ms] | T | T128 | T255 |
| | Counter contact [16 bit] | C | C0 | C255 |
| Word | Input register | X | X0 | X15999 |
| | Output register | Y | Y0 | Y15999 |
| | Internal auxiliary register | M | M0 | M14999 |
| | File register | R | R0 | R4099 |
| | Special register | F | F0 | F299 |
| | Link register | L | L0 | L999 |
| | Timer current value [10ms] | T | T0 | T127 |
| | Timer current value [100ms] | T | T128 | T255 |
| | Counter current value [16 bit] | C | C0 | C255 |
| | Data register | D | D0 | D28999 |

2.2.6 Monitorable Device in GP/LP

The status can be changed by monitoring the connected devices in GP/LP.

The following is a list of devices available in this menu, please refer to 'Available devices' for available device range.

| Type | Name | Device | Note |
|------|---------------|-----------------------------|--------|
| Bit | X | Input relay | |
| | Y | Output relay | |
| | M | Internal auxiliary relay | |
| | F | Special relay | |
| | S | Status relay | |
| | L | Link relay | |
| | T | Timer contact | |
| | C | Counter contact | |
| Word | X | Input register | |
| | Y | Output register | |
| | M | Internal auxiliary register | |
| | F | Special register | |
| | L | Link register | |
| | T | Timer current value | |
| | C | Counter current value | |
| | D | Data register | 16 bit |
| R | File register | | |

Make Life Easy: Autonics

* Dimensions or specifications on this manual are subject to change and some models may be discontinued without notice.

MTA-GPLPC_Autonics-V1.0-1907US