

Safety Door Lock Slide Key Unit

SFDL-SDK Series

INSTRUCTION MANUAL

DRW190964AB

Autonics

Thank you for choosing our Autonics product.

Read and understand the instruction manual and manual thoroughly before using the product.

For your safety, read and follow the below safety considerations before using.

For your safety, read and follow the considerations written in the instruction manual, other manuals and Autonics website.

Keep this instruction manual in a place where you can find easily.

The specifications, dimensions, etc. are subject to change without notice for product improvement. Some models may be discontinued without notice.

Follow Autonics website for the latest information.

Safety Considerations

- Observe all 'Safety Considerations' for safe and proper operation to avoid hazards.
- ⚠ symbol indicates caution due to special circumstances in which hazards may occur.

⚠ Warning Failure to follow instructions may result in serious injury or death.

01. Fail-safe device must be installed when using the unit with machinery that may cause serious injury or substantial economic loss. (e.g. nuclear power control, medical equipment, ships, vehicles, railways, aircraft, combustion apparatus, safety equipment, crime/disaster prevention devices, etc.)

Failure to follow this instruction may result in personal injury, economic loss or fire

02. Do not use the unit in the place where flammable/explosive/corrosive/toxic gas, high humidity, direct sunlight, radiant heat, vibration, impact, or salinity may be present.

Failure to follow this instruction may result in explosion or fire.

03. Do not disassemble or modify the unit.

Failure to follow this instruction may result in personal injury due to loss of safety function.

04. Check installed status of the switch and slide key unit, operating status, and signs of damage, modification, tampering on a regular basis.

Failure to follow this instruction may result in personal injury due to malfunction of the product and safety function.

05. When keeping the lock out key by wearing on the wrists, keep cautious that the spring strap is not be rolled into the machine.

Failure to follow this instruction may result in personal injury.

06. When operating the slide handle, be cautious to avoid catching hand.

Failure to follow this instruction may result in personal injury.

⚠ Caution Failure to follow instructions may result in injury or product damage.

01. Use the unit within the rated specifications.

Failure to follow this instruction may result in product damage.

02. Use a dry cloth to clean the unit, and do not use water or organic solvent.

Failure to follow this instruction may result in fire.

03. Install this product on the light door under 20kg.

Failure to follow this instruction may result in product damage.

04. Do not drop or impact the product.

Failure to follow this instruction may result in product damage or malfunction.

05. Do not close the door without the bolt slide.

Failure to follow this instruction may result in product damage.

06. Do not use the switch or cable with excessive force.

Failure to follow this instruction may result in product damage or malfunction.

07. Do not slide the product with excessive force.

Failure to follow this instruction may result in product damage or malfunction.

08. Do not use the lock out key with power over 1 N·m. To prevent product damage, attach the enclosed warning label near the product.

Failure to follow this instruction may result in product damage or malfunction.

09. Press lightly towards the product and then turn the lock out key to operate.

Failure to follow this instruction may result in product damage or malfunction.

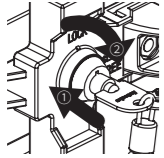

10. When the door is closed or the lock out key is put out, do not forcibly use the slide handle.

Failure to follow this instruction may result in product damage or malfunction.

11. When the slide key unit is installed, do not use the spare operation key besides the operation key on the slide key unit to operate switch.

Failure to follow this instruction may result in personal injury or fire due to loss of safety function.

Cautions during Use

- Follow instructions in 'Cautions during Use'. Otherwise, it may cause unexpected accidents.
- This product is dedicated for Autonics safety door lock switch, SFDL Series. Do not use with the door lock switch from other manufacturer.
- Turn the lock out key to the 'SLIDE LOCK' direction to open the door, and carefully manage the lock out key.
Do not let others operate the slide key unit.
- Durability of the slide key unit can be differed according to opening condition. Check the environment where the product is used in and machine which the product is used for, and use the product within the rated number of mechanical durability.
- Use the slide handle only in the right and left direction as following image.

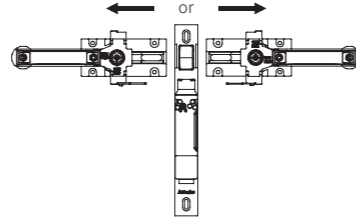

- For the detailed information such as installation and use about the safety door lock switch, SFDL Series, which is used with the slide key unit, please refer to the instruction manual of the safety door lock switch.

Product Components

- Slide key unit mounting part
- Slide key unit handle part
- Inner lever
- Operation key (SFD-KH)
- Lock out key: 2
- Spring strap for lock out key
- Door lock switch mounting M4 bolt: 4 / M4 spring washer: 4
- Operation key mounting M4 bolt: 2 / M4 spring washer: 2 / M4 flat washer: 2
- Each Korean / English warning label

Specifications

Model	SFDL-SDK
Ambient temperature	-10 to 55°C, storage: -20 to 75°C (non-freezing or non-condensation)
Ambient humidity	≤ 95%RH, storage: 35 to 85%RH (non-freezing or non-condensation)
Mechanical durability	≥ 20,000 times
Material	Polyamide 66
Unit weight (Packaged)	≈ 720 g (≈ 900g)

Unit Description

- Following image shows the status when door is opened.

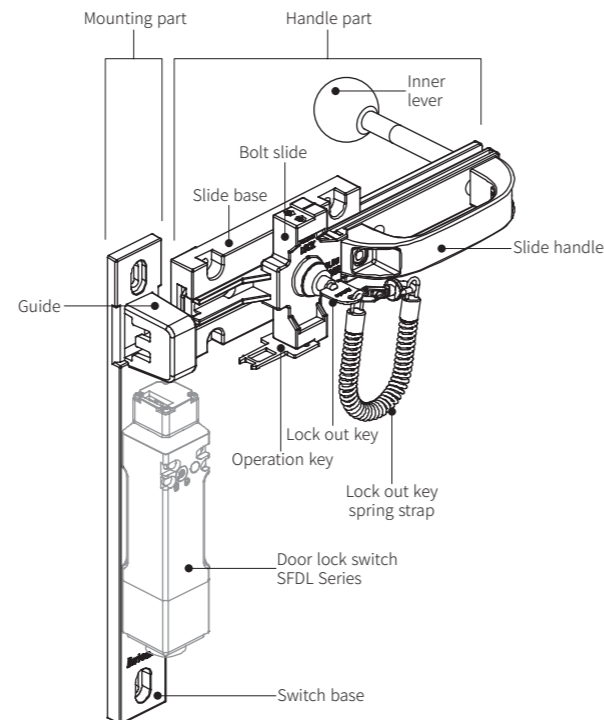

Dimensions

- Unit: mm, For the detailed dimensions of the product, follow the Autonics web site.
- Figures in () can be differed according to the installing environment and product operation.

■ When the door is opened

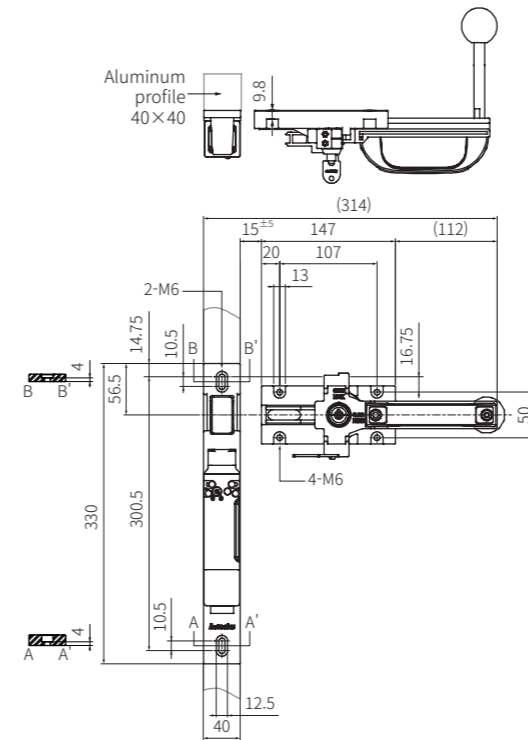

■ When the door is closed

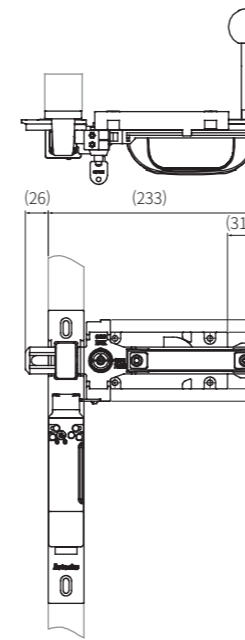

■ Side

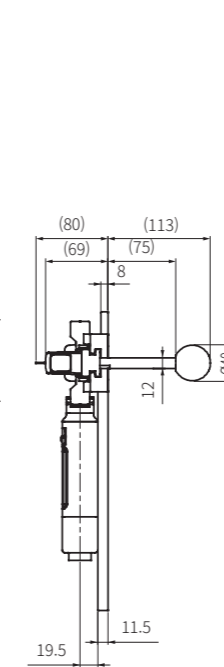

■ Operation key (SFD-KH)

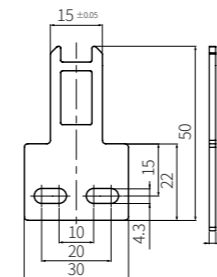

Cautions during Installation

- Tighten the bolt with the designated tightening torque of each, using spring washer/flat washer. Failure to follow this instruction may result in product failure or damage.

Bolt	Tightening torque
Slide key unit mounting bolt (M6 BOLT)	6.0 to 7.0 N·m
Operation key mounting bolt	2.4 to 2.8 N·m
Switch mounting bolt	0.75 to 1.15 N·m

Above tightening torque is for the status of installing with spring washer/flat washer.

- Apply additional methods such as glue to prevent loosening of the bolt. Mount the slide base with all of 4 bolts.

- In order that the operation key is not to be tilted, mount the operation key tightly onto the operation key mounting surface.

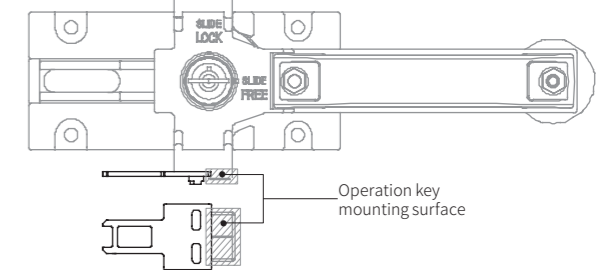

- Install the between bolt slide and guide aligning them within ±0.5 mm from the center line. Excessive wear and damage on the product may result in trouble in operating the slide key unit.

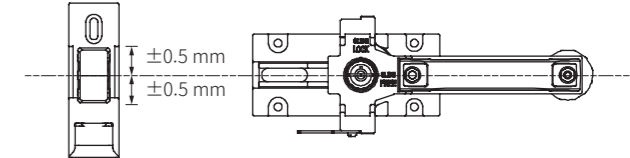

Inner Lever Installation

- Disassemble the handle fixing bolt using 4mm hexagon wrench.

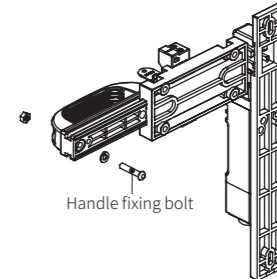

- Tighten the hexagon nut+spring washer+inner lever with the designated tightening torque using a spanner with 10mm width. If the inner lever is screwed loosely, it may result in product failure.

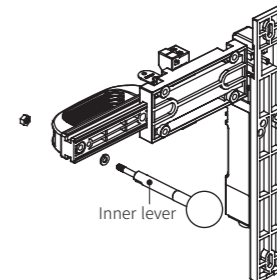

Bolt	Tightening torque
Inner lever	9 to 10 N·m

- Keep cautious not to lose the hexagon nut and spring washer, when disassemble the handle fixing bolt.
- Do not use handle when the handle fixing bolt is disassembled. It may result in product failure.
- This inner lever is dedicated to Autonics SFDL-SDK. Do not use it for another product or purpose.