

User Manual

Safety Light Curtains

SFL/SFLA Series

MSO-SFL(A)U1-V1.0-2009US

Thank you for purchasing an Autonics product.
This user manual contains information about the product and its proper use,
and should be kept in a place where it will be easy to access.

Preface

Thank you for purchasing Autonics product.





Please familiarize yourself with the information contained in the Safety Considerations section before using this product.

This user manual contains information about the product and its proper use, and should be kept in a place where it will be easy to access.

User Manual Guide



- Please familiarize yourself with the information in this manual before using the product.
- This manual provides detailed information on the product's features. It does not offer any guarantee concerning matters beyond the scope of this manual.
- This manual may not be edited or reproduced in either part or whole without permission.
- A user manual is not provided as part of the product package. Visit our web site (www.autonics.com) to download a copy.
- The manual's content may vary depending on changes to the product's software and other unforeseen developments within Autonics, and is subject to change without prior notice. Upgrade notice is provided through our homepage.
- We contrived to describe this manual more easily and correctly. However, if there are any corrections or questions, please notify us these on our website.

User Manual Symbols

Symbol	Description
 Note	Supplementary information for a particular feature.
 Warning	Failure to follow instructions can result in serious injury or death.
 Caution	Failure to follow instructions can lead to a minor injury or product damage.
 Ex.	An example of the concerned feature's use.
※1	Annotation mark.

Safety Considerations

- Following these safety precautions will ensure the safe and proper use of the product and help prevent accidents, as well as minimizing possible hazards.
- Safety precautions are categorized as Warnings and Cautions, as defined below:

 Warning	Warning	Failure to follow the instructions may lead to a serious injury or accident.
 Caution	Caution	Failure to follow the instructions may lead to a minor injury or accident.

Warning

- 1. Fail-safe device must be installed when using the unit with machinery that may cause serious injury or substantial economic loss. (e.g. nuclear power control, medical equipment, ships, vehicles, railways, aircraft, combustion apparatus, safety equipment, crime/disaster prevention devices, etc.)**
Failure to follow this instruction may result in personal injury, economic loss or fire.
- 2. Do not use the unit in the place where flammable/explosive/corrosive gas, high humidity, direct sunlight, radiant heat, vibration, impact, or salinity may be present.**
Failure to follow this instruction may result in explosion or fire.
- 3. Do not connect, repair, inspect, or replace the unit while connected to a power source.**
Failure to follow this instruction may cause malfunction or danger due to the safety-related function that does not operate properly.
For more information, please refer to laws, regulations and standards in the country or region.
- 4. Do not disassemble or modify the unit.**
Failure to follow this instruction may result in personal injury or fire. In addition, the manufacturer does not guarantee the performance and functionality.
- 5. After 3 seconds of power input, use a machine or mechanical system.**
Failure to follow this instruction may cause malfunction or danger due to the safety-related function that does not operate properly.
- 6. Responsible person for use is an operator who:**
- is fully knowledgeable about the installation, settings, use and maintenance of the product
- is familiar with the requirements of laws, regulations and standards in the country or region where the product is installed and used.
Responsible person for use has an obligation to educate the requirements to machine users.
Machine users are persons who have been fully trained by the responsible person for use and can operate the machine correctly.
When any error occurs during the operation of the machine control system, they have a responsibility to report it to the responsible person for use immediately.
If an unqualified person operates the product, it may result in personal injury, economic loss or fire.
- 7. Qualified personnel shall carry out installation, configuration and combination with the machine control system.**
If an unqualified person carries out installation, configuration and combination with the machine control system, it may cause malfunction or result in accidents due to undetected human body.
- 8. Make sure that only the responsible person uses the keys or tools for accessing and setting the light curtains.**
Failure to follow this instruction may cause malfunction or result in accidents.
- 9. When the machine is not operating after installation, check that functions and settings of the product operate correctly as you intended.**
Failure to follow this instruction may result in personal injury due to undetected human body.
- 10. Always make sure that the safety distance between the light curtain and the hazardous part (hazardous zone or hazardous source) of the machine.**
The machine may not stop before an operator reaches the hazardous zone so that it may result in personal injury. For more information on the safety distance, please refer to laws, regulations and standards in the country or region.
- 11. To access the hazardous part (hazardous zone or hazardous source) of the machine, you shall install the light curtain as human body passes through the detection zone. If the hazardous part of the machine is accessible beyond the detection zone, install additional guards. In addition, when working in the hazardous zone, make sure that a part of human body is within the detection zone.**
If the installation does not detect the human body, it may result in personal injury.
- 12. Do not arrange or use the light curtain as a reflective or retro-reflective type with reflector.**
If the installation does not detect the human body, it may result in personal injury.
- 13. Do not use the light curtain to detect flying objects toward the detection zone.**
If there is a risk, take additional safety measures, such as installing an additional safety guard.

- 14. The auxiliary output (AUX) is non-safety output, therefore, do not use it for safety purposes.**
Failure to follow this instruction may result in serious injury because the safety cannot be guaranteed.
- 15. The lamp output (Lamp) is non-safety output, therefore, do not use it for safety purposes.**
Failure to follow this instruction may result in serious injury because the safety cannot be guaranteed.
- 16. Only qualified personnel shall use the PC setting tool (atLightCurtain) to configure functions of light curtain and manage the changed settings.**
If an unqualified person tries to change settings of function via the PC setting tool, it may cause malfunction or result in personal injury due to undetected human body.
- 17. After setting or changing the function of light curtain via the PC setting tool, check that light curtain operates as you intended.**
Failure to follow this instruction may result in personal injury.
- 18. When installation, if you have changed the configuration of light curtain (replacement of light curtain, change the number of beams, change the number of series connection, etc.), set the function of the light curtain via the PC setting tool again.**
Failure to follow this instruction may result in personal injury due to unintended settings.
- 19. If the (master) receiver has been replaced, send the setting information of PC setting tool to the replaced receiver gain.**
Failure to follow this instruction may result in personal injury due to unintended settings.
- 20. Install the devices for releasing Interlock condition (e.g. switch) in a location where the entire hazardous zone can be seen or the devices cannot be handled within the hazardous zone.**
- 21. When restarting the machine in interlock condition, make sure that no operators are in the hazardous zone.**
Failure to follow this instruction may result in personal injury due to undetected human body.
- 22. Follow the requirements described in this manual for the muting devices and installation method to use muting function.**
For more information, please refer to laws, regulations and standards in the country or region. Failure to follow these requirements, the functions and performance are not guaranteed. It may result in personal injury.
- 23. Install the muting devices in a location that can be changed by only qualified and responsible person for use.**
Change the installation location under the supervision of responsible person for use.
- 24. The muting function temporarily stops the safety related functions of light curtain.**
If the function is activated, take additional safety measures for the safety of the machine control system.
- 25. When the muting function is activated, make sure that no operator is in the hazardous zone.**
Take additional safety measures to prevent the human body from entering the hazardous zone.
- 26. When you need to inform that the muting function is activating, install the indicators with any forms (e.g. alarm lamp) where it can be seen from all sites.**
For more information, please refer to laws, regulations and standards in the country or region.
- 27. Qualified and responsible person for use should conduct the risk assessment on the time related to the muting function, set the time correctly according to the conditions described in this manual. In particular, set the muting timeout (T2) to a finite value in the PC setting tool.**
Failure to follow this instruction may cause the function failure of safety related and result in personal injury or fire.
- 28. When you use the auto scan for muting zone via PC setting tool, the OSSD output may temporarily go to ON state due to the operation of line or facilities for scan and measurement. Therefore, safety measures in workplace shall be implemented.**
If there is a risk, take additional safety measures, such as installing an additional safety guard.
- 29. The installation environment and timing chart shown in the PC setting tool are examples for your understanding. Make sure that the qualified and responsible person for use check the light curtain operates in the actually installed site as intended.**
Failure to follow this instruction may result in personal injury due to undetected human body.
- 30. Follow the requirements described in this manual for the devices and installation method to use the override function.**
For more information, please refer to laws, regulations and standards in the country or region. Failure to follow these requirements, the functions and performance are not guaranteed. It may result in personal injury.
- 31. Connect the override switch to reset input to use the override function.**
Failure to release the override condition with the override switch may result in personal injury.
- 32. The override function temporarily stops the safety related functions of light curtain. Therefore, safety measures in workplace shall be implemented.**
If the function is activated, take additional safety measures for the safety of the machine control system.
- 33. When the override function is activated, make sure that no operator is in the hazardous zone.**
Take additional safety measures to prevent the human body from entering the hazardous zone.
- 34. When you need to inform that the override function is activating, install the indicators with any forms (e.g.**

- alarm lamp) where it can be seen from all sites.**
For more information, please refer to laws, regulations and standards in the country or region.
- 35. Qualified and responsible person for use should conduct the risk assessment on the time related to the override function, set the time correctly according to the conditions described in this manual. In particular, set the override timeout to a finite value in the PC setting tool.**
Failure to follow this instruction may cause the function failure of safety related and result in personal injury or fire.
- 36. After setting the fixed blanking function, check that it operates as intended.**
Failure to follow this instruction may result in personal injury due to undetected human body.
- 37. If the tolerance is set for the fixed blanking function, the detection capability will be larger.**
Calculate the safety distance suitable for the minimum detection capability to secure minimum safety distance.
- 38. If you use the fixed blanking function, conduct additional safety measures to prevent a part of human body from entering the hazardous zone passing by beams for the blanking zone.**
- 39. After setting the floating blanking function, check that it operates as intended.**
Failure to follow this instruction may result in personal injury due to undetected human body.
- 40. If the tolerance is set for the floating blanking function, the detection capability will be larger.**
Calculate the safety distance suitable for the minimum detection capability to secure minimum safety distance.
- 41. If you use the floating blanking function, conduct additional safety measures to prevent a part of human body from entering the hazardous zone passing by beams for the blanking zone.**
- 42. If you use the auto scan function for the fixed and floating blanking zone via the PC setting tool, the OSSD output temporarily goes to the OFF state.**
Please note that the operating status of the light curtain may be changed.
- 43. If you use the reduced resolution function, the detection capability will be larger.**
Calculate the safety distance suitable for the minimum detection capability to secure minimum safety distance.
- 44. Only qualified and responsible person for use shall use the factory reset via the PC setting tool. Also, check the safety distance and the operation of the light curtain again.**
Failure to follow this instruction may result in personal injury due to undetected human body.
- 45. Check 'Connections' before wiring. And make sure that there are no safety problems.**
Failure to follow this instruction may result in fire.
- 46. When using PNP output, be sure to connect the load between the OSSD output wire and 0V. Do not short the OSSD output wires to +24V.**
Incorrect wiring or shut down of the power supply is dangerous because the OSSD output is always in ON state.
- 47. When using NPN output, be sure to connect the load between the OSSD output wire and +24V. Do not short the OSSD output wires to 0V.**
Incorrect wiring or shut down of the power supply is dangerous because the OSSD output is always in ON state.
- 48. Use only the two OSSD output wires in this product to construct safety systems, and do not use output signals (e.g. auxiliary output) other than the OSSD output for safety purposes.**
When you use only one OSSD output or use other output signal as a safety output, the machine cannot be stopped in the event of a malfunction and result in personal injury due to the safety related function failure.
- 49. When wiring, all input/output wires with double insulation or reinforced insulation should be used between the circuits.**
Failure to follow this instruction may result in fire.
- 50. Do not install all input/output wires in the same piping with high voltage wire and power line.**
Failure to follow this instruction may cause malfunction or dangerous due to the safety related function do not operate properly.
- 51. Use a separate power supply for the load and the product, and do not exceed the specified ratings.**
Failure to follow this instruction may result in damage or malfunction of the product.



Caution

1. **Use the product within the rated specifications.**
Failure to follow this instruction may result in fire or product damage.
2. **Use a dry cloth to clean the unit, and do not use water or organic solvent.**
Failure to follow this instruction may result in fire.
3. **Use the cable within the rated length and do not modify, change, and extend the cable.**
If the cable is longer, it may cause malfunction or dangerous due to the safety related function do not operate properly.
4. **To use the light curtain in "PSDI mode," configure the appropriate control circuit between the light curtain and the machine according to the requirements of laws, regulations and standards in the country or region.**
5. **Do not use the product outdoors.**
Failure to follow this instruction may result in damage and malfunction of the product.
6. **Keep the product away from metal chip, dust, and wire residue which flow into the unit.**
Failure to follow this instruction may result in personal injury due to the malfunction of the light curtain.
7. **Be sure for responsible person for use to change the password of PC setting tool to prevent the setting change by the machine users (or operator).**
Securely manage your password and avoid forgetting the password.
Failure to follow this instruction may result in personal injury due to the malfunction of the light curtain.
8. **You must conduct regular inspections and maintenance procedures within six months according to the items listed on the "10. Check and maintenance."**
Failure to follow this instruction may result in personal injury due to the malfunction of the light curtain.
9. **Check the installation status, normal operation, breakage, modification, and manipulation in the situations shown below, and conduct the weekly inspection.**
 - ① **When starting the safety system for the first time**
 - ② **When replacing the accessories of the safety system**
 - ③ **When the safety system has not been operated for a long time**
Failure to follow this instruction may result in personal injury because the safety-related function may not work properly due to the malfunction of the product.

Caution during Use

1. **Follow instructions in "Cautions during Use". Otherwise, it may cause unexpected accidents.**
 2. **The power input of 24VDC model is insulated and limited voltage/current or supply via power supply with SELV and Class 2.**
 3. **When supplying power with SMPS, ground the FG terminal and connect the noise suppression capacitor between 0V and FG terminal.**
 4. **When installing the light curtain, make sure that the bottom indicators of the emitter and receiver are aligned exactly.**
 5. **Install the light curtain in a place where the emitter and receiver are not affected by walls or reflecting surfaces.**
 6. **If you use the light curtain as several sets, arrange them not to interfere with each other, or install with a shading plate.**
 7. **Do not install the light curtain in place where it is exposed to intense disturbance light (such as direct sunlight, sunlight, spotlights fluorescent lights, and etc.) or reflected light from glossary surface is directly incident on the receiver. If it is difficult to install in such a place, take additional safety measures using shading plates, hoods, etc.**
Failure to follow this instruction may cause malfunction or dangerous due to the safety related function do not operate properly.
 8. **Make sure that any unused wires, when installing the product, should be insulated.**
 9. **Make sure that removable parts (including packing, end caps, product wires, covers, etc.) are properly assembled. Also, tighten the screws with specified tightening torque.**
Failure to follow this instruction may cause product degradation.
 10. **Assessment of conformity to the required safety level is evaluated for the entire system. Please consult with a certified certification body regarding the assessment procedure.**
 11. **It should be done away regarded as an industrial waste.**
For more information, please refer to laws, regulations and standards in the country or region.
 12. **This product may be used in the following environments.**
 - Altitude max. 2000m
 - Pollution degree 3
 - Installation category II
- ※The above specifications are subject to change and some models may be discontinued without notice.
 ※Be sure to follow cautions written in the instruction manual, user manual and the technical descriptions (catalog, homepage).

Table of Content

Preface	3
User Manual Guide.....	4
User Manual Symbols.....	5
Safety Considerations	6
Caution during Use.....	9
Table of Content.....	11
1. Overview.....	13
1.1 Features.....	13
1.2 Components and sold separately	13
1.2.1 Components	13
1.2.2 Sold separately.....	13
1.3 Ordering information	14
1.4 Feature comparison.....	14
2. Specifications	15
2.1 Standard type	15
2.2 Advanced type.....	15
2.3 Common.....	16
2.4 IEC 61508 parameters.....	17
2.5 Models.....	18
2.5.1 Finger detection (SFL(A)14-□, Ø14mm)	18
2.5.2 Hand detection (SFL(A)20-□, Ø20mm)	19
2.5.3 Hand-Body detection (SFL(A)30-□, Ø30mm).....	20
2.5.4 How to calculate the response time (RT) for the series connection.....	21
3. Dimensions	22
3.1 Emitter / Receiver.....	22
3.1.1 Finger detection (Ø14mm).....	22
3.1.2 Hand detection (Ø20mm)	24
3.1.3 Hand - Body detection (Ø30mm)	26
3.2 Brackets (sold separately).....	28
3.2.1 Top/Bottom adjustable bracket (BK-SFL-TBA).....	28
3.2.2 Top/Bottom bracket (BK-SFL-TBF)	28
3.2.3 Side adjustable bracket (BK-SFL-SA)	29
3.2.4 Side bracket (BK-SFL-SF).....	29
3.3 Sold separately.....	30
3.3.1 Power I/O cable (connector type).....	30
3.3.2 Power I/O cable (wire type)	30
3.3.3 Connector cable (socket type)	30
3.3.4 Connector cable (socket-plug type)	31
3.3.5 Series connection cable	31
3.3.6 Lamp output cable	31
3.3.7 USB/Serial communication converter	32
3.3.8 SFL / SFLA dedicated converter cable	32
3.3.9 Test piece	32
3.4 Unit descriptions.....	33
3.4.1 Status indicators	35
3.4.2 7-Segment display.....	36
3.4.3 Setting switch	37
4. General functions.....	38
4.1 Mode and state	38
4.2 Self-test.....	38
4.3 Alarm for incident light level	39
4.4 OSSD output.....	40
4.5 Mutual interference prevention	40

4.5.1	Change settings.....	40
5.	Safety-related function	41
5.1	Interlock.....	42
5.1.1	Auto-reset.....	42
5.1.2	Manual reset	42
5.1.3	Wiring.....	45
5.1.4	Change settings.....	45
5.2	Lockout reset	46
5.2.1	Wiring.....	46
5.3	External Device Monitoring (EDM)	47
5.3.1	Wiring.....	47
5.3.2	Change settings.....	47
5.4	Muting.....	48
5.4.1	Standard mode	48
5.4.2	Exit-only mode	61
5.4.3	Change settings.....	66
5.5	Override.....	67
5.5.1	Wiring.....	68
5.5.2	Change settings.....	69
5.6	Blanking.....	70
5.6.1	Fixed blanking.....	70
5.6.2	Floating blanking.....	73
5.6.3	Use the floating blanking with fixed blanking zone.....	74
5.6.4	Change settings.....	75
5.7	Reduced resolution.....	76
5.7.1	Change settings.....	77
6.	Other functions.....	78
6.1	Series connection	78
6.2	Change sensing distance	81
6.2.1	Change settings.....	81
6.3	Set NPN or PNP	82
6.3.1	Setting change.....	82
6.4	External test.....	83
6.4.1	Wiring.....	83
6.5	Auxiliary output (AUX 1/2).....	84
6.5.1	Wiring.....	85
6.5.2	Setting change.....	85
6.6	Lamp output (Lamp 1/2).....	86
6.6.1	Wiring.....	87
6.6.2	Setting change.....	87
7.	Wiring.....	89
7.1.	I/O connection diagram	89
7.1.1	Input circuit diagram.....	89
7.1.2	Output circuit diagram	89
7.2	Example of wiring diagram.....	90
7.3	Wiring diagram for interlock and EDM	92
7.4	Wiring diagram for reset-hold	94
7.5	Wiring diagram for muting.....	96
8.	Configuration software, atLightCurtain.....	98
8.1	System requirements	98
8.2	USB to Serial connection	98
9.	Installation	99
9.1	Installation conditions	99
9.2	Safety distance	100
9.2.1	Safety distance according to ISO 13855 (EN ISO 13855, KS C 13855).....	100

9.3	How to install and adjust your light curtain.....	103
9.4	Installation for mutual interference prevention.....	103
9.4.1	When using a series connection	103
9.4.2	When using one set of the light curtain	104
9.4.3	About installation of a reflective surface.....	106
9.5	Mount brackets.....	107
9.5.1	Top/Bottom adjustable bracket (BK-SFL-TBA).....	107
9.5.2	Top/Bottom bracket (BK-SFL-TBF).....	107
9.5.3	Side adjustable bracket (BK-SFL-SA)	108
9.5.4	Side bracket (BK-SFL-SF).....	108
9.5.5	Cautions when using the brackets	109
10.	Check and maintenance.....	110
10.1	Check installation conditions.....	110
10.2	Check wiring connection	110
10.3	Safety-related system-check when the operation stops	111
10.4	Safety-related system-check in operation	112
10.5	Daily inspection.....	112
10.6	Regular inspection	112
11.	Troubleshooting.....	113
11.1	Error code (Lockout condition).....	113
11.2	Warning code.....	115
12.	Appendix	116
12.1	Glossary	116
12.2	Manual revision history.....	117

1. Overview

1.1 Features

- Select the light curtain suitable for the environmental condition with three detection capabilities
 - : finger, hand, and hand-body
- Variable height for protection: 144 to 1868mm
- Expend up to 4 sets of 400 beams with series connection
- Built-in various safety-related functions to deal with the field conditions
 - : interlock, lockout, EDM, muting, override, blanking, and reduced resolution, etc.
- SFLA Series supports various functions via the dedicated software (atLightCurtain)
 - : Monitoring for real-time incident light level (SFL Series also supports it.)
 - : Provide a variety of functions to set including automatic setting for muting and blanking zone
 - : Save setting information of light curtain and apply the same settings to multiple light curtains
- Four mounting brackets (BK-SFL-□, sold separately) support various installation environments
- Select the sensing distance suitable for installation environment: Long or short mode
- Easy beam adjustment with the indicators at the top and bottom of the light curtain
- Easy switching NPN or PNP output via switch or dedicated software (atLightCurtain)
- Excellent visibility for the status of the light curtain with 7-segment display
- Built-in self-diagnosis function such as mutual interference prevention and disturbance light detection
- Easy to identify the operating status with the upper OSSD indicator without an additional device
- Four kinds of non-safety outputs for a variety of environmental conditions: AUX 1/2, and Lamp 1/2
- The product structure conforms with international safety regulations and standards
 - : Type 4 ESPE(AOPD), SIL3, SIL CL3, Cat. 4, PL e, CE, UL Listed, S Mark, KCs (some of the models)
- The protection structure of IP65 and IP67 (IEC standard)

1.2 Components and sold separately

1.2.1 Components

It is included in the box.

- i. Emitter and receiver
- ii. Instruction manual

1.2.2 Sold separately

It is not included in the box. You can purchase them separately.

- i. Power I/O cable (connector type, SFL-BCT(R))
- ii. Power I/O cable (wire type, SFL-C□T(R))
- iii. Connector cable (socket type, CID8-□T(R))
- iv. Connector connection cable (socket-plug type, C1D8-□T(R))
- v. Series connection cable (SFL-EC□T(R))
- vi. Lamp output cable (SFL-LC)
- vii. Brackets (Top/Bottom (adjustable), Side (adjustable): BK-SFL-□□)
- viii. USB / Serial communication converter (SCM-US)
- ix. SFL / SFLA dedicated converter cable (EXT-SFL)
- x. Test piece (SFL-T□)

1.3 Ordering information

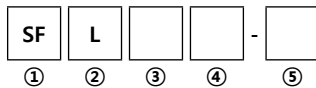

Item		Description
① Model	SF	Safety component
② Model type	L	Light curtain
③ Function	No mark	Standard type
	A	Advanced type
④ Detection capability	Number	Minimum size of detection object (unit: mm)
⑤ Number of beams	Number	The number of optical axes

1.4 Feature comparison

- : supported (available to the detailed setting)
○: supported (not available to the detailed setting)
×: not supported

Classification	Function	SFL Series (standard type)	SFLA Series (advanced type)
General functions	Mode and status		
	Self-test		
	RS485 communication (between emitter and receiver)	○	○
	Monitor light incident level		
	OSSD output		
Safety-related functions	Mutual interference prevention		
	Interlock	○	●
	Lockout reset	○	○
	External device monitoring (EDM)	○	●
	Muting	○	●
	Override	○	●
	Blanking (Fixed blanking and floating blanking)	×	●
Reduced resolution	×	●	
Other functions	Series connection		
	Select sensing distance	○	○
	Select NPN or PNP		
	External test (light emission stops) ^{※1}		
	Auxiliary output (AUX)	○	●
	Lamp output (Lamp)	○	●
PC connection	○	●	

※1: In case of external test, it can be set by wiring.

※When setting with the switch, you can select either activated or deactivated state.

※When connecting to a PC, you can set the details besides selecting to enable or disable the functions via atLightCurtain.
For more information, see "user manual for atLightCurtain."

※For more information on the general functions, see "4. General functions".

※For more information on the safety-related functions, see "5. Safety-related function".

※For more information on the other functions, see "6. Other functions".

2. Specifications

2.1 Standard type

Type	Standard type		
Models	SFL14- □	SFL20- □	SFL30- □
Sensing type	Through-beam		
Light source	Infrared LED (855 nm)		
Effective aperture angle (EAA)	Within $\pm 2.5^\circ$ when the sensing distance is greater than 3 m for both emitter and receiver.		
Sensing distance	Short - Long mode (setting switch)		
Short mode	0.2 to 5 m	0.2 to 8 m	0.2 to 8 m
Long mode	0.2 to 10 m	0.2 to 15 m	0.2 to 15 m
Detection capability	Ø 14 mm (finger)	Ø 20 mm (hand)	Ø 30 mm (hand-body)
Detection object	Opaque object		
Number of optical axes ⁰¹⁾	15 to 111	12 to 68	42 to 75
Protective height	144 to 1,008 mm	183 to 1,023 mm	1,043 to 1,868 mm
Optical axis pitch	9 mm	15 mm	25 mm
Series connection	Max. 3 SET (≤ 300 optical axes)		

※01) It may differ depending on the models. For more information, see the "2.5 Models".

2.2 Advanced type

Type	Advanced type		
Models	SFLA14- □	SFLA20- □	SFLA30- □
Sensing type	Through-beam		
Light source	Infrared LED (855 nm)		
Effective aperture angle (EAA)	Within $\pm 2.5^\circ$ when the sensing distance is greater than 3 m for both emitter and receiver.		
Sensing distance	Short - Long mode (setting switch or atLightCurtain)		
Short mode	0.2 to 5 m	0.2 to 8 m	0.2 to 8 m
Long mode	0.2 to 10 m	0.2 to 15 m	0.2 to 15 m
Detection capability	Ø 14 mm (finger)	Ø 20 mm (hand)	Ø 30 mm (hand-body)
Detection object	Opaque object		
Number of optical axes ⁰¹⁾	15 to 199	12 to 124	9 to 75
Protective height	144 to 1,800 mm	183 to 1,863 mm	218 to 1,868 mm
Optical axis pitch	9 mm	15 mm	25 mm
Series connection	Max. 4 SET (≤ 400 optical axes)		

※01) It may differ depending on the models. For more information, see the "2.5 Models".

2.3 Common

Power supply	24 VDC \pm 20 % (Ripple P-P: \leq 10 %)
Current consumption ⁰¹⁾	Emitter: \leq 106 mA, receiver: \leq 181 mA
Response time ⁰¹⁾	T _{OFF} (ON \rightarrow OFF): \leq 32.3 ms, T _{ON} (OFF \rightarrow ON): \leq 76.6 ms
Safety related output : OSSD output	NPN or PNP open collector Load voltage ⁰²⁾ : ON - 24 VDC \pm (except for the residual voltage), OFF - 0 VDC \pm , Load current ⁰³⁾ : \leq 300 mA, Residual voltage ⁰⁴⁾ : \leq 2 VDC \pm (except for voltage drop due to wiring), Load capability: \leq 2.2 μ F, Leakage current: \leq 2.0 mA, Wire resistance of load: \leq 2.7 Ω
Auxiliary output (AUX 1/2) ⁰⁵⁾	NPN or PNP open collector Load voltage: \leq 24 VDC \pm , Load current: \leq 100 mA, Residual voltage: \leq 2 VDC \pm (except for voltage drop due to wiring)
Lamp output (LAMP 1/2) ⁰⁵⁾	NPN or PNP open collector Load voltage: \leq 24 VDC \pm , Load current: \leq 300 mA, Residual voltage: \leq 2 VDC \pm (except for voltage drop due to wiring) Incandescent lamp: 24 VDC \pm , 3 to 7 W, LED lamp: Load current \leq 50 to 300 mA
External input	Reset input, mute 1, 2 input, EDM, external test When setting NPN output ON: 0 - 3 VDC \pm , OFF: 9 - 24 VDC \pm or open, short-circuit current: \leq 3 mA When setting PNP output ON: 9 - 24 VDC \pm , OFF: 0 - 3 VDC \pm or open, short-circuit current: \leq 3 mA
Protection circuit	Reverse power polarity, reverse output polarity, output short-circuit over-current protection
Safety-related functions	Interlock (reset hold), external device monitoring (EDM), muting/override, Blanking (fixed blanking, floating blanking), reduced resolution
General functions	Self-test, alarm for reduction of incident light level, mutual interference prevention
Others functions	Change of sensing distance, switching to NPN or PNP, external test (light emission stops), auxiliary output (AUX 1, 2), lamp output (LAMP1, 2)
Synchronization type	Timing method by synchronous line
Insulation resistance	\geq 20M Ω (at 500 VDC \pm megger)
Noise immunity	\pm 240 VDC \pm the square wave noise (pulse width: 1 μ s) by the noise simulation
Dielectric strength	1,000 VAC \sim 50/60Hz for 1 minute
Vibration	0.7 mm amplitude at frequency of 10 to 55Hz (for 1 min), 20 sweeps in each X, Y, Z direction
Shock	100 m/s ² (\approx 10 G), pulse width 16 ms in each X, Y, Z direction for 1,000 times
Ambient illumination	Incandescent lamp: \leq 3,000 lx, sunlight: \leq 10,000 lx (illumination of light receiving surface)
Ambient temperature	-10 to 55 °C, storage: -20 to 70 °C (non-freezing or non-condensation)
Ambient humidity	35 to 85 %RH, storage: 35 to 95 %RH (non-freezing or non-condensation)
Protection structure	IP65, IP67 (IEC standard)
Material	Case: Aluminum, Front cover and sensing part: Polymethyl methacrylate, End cap: polycarbonate, Cable: polyurethane (PUR)
Approval	
International standards	UL 508, CSA C22.2 No. 14, ISO 13849-1 (PL e, Cat. 4), ISO 13849-2 (PL e, Cat. 4), UL 61496-1 (Type 4, ESPE), UL 61496-2 (Type 4, AOPDs), IEC/EN 61496-1 (Type 4, ESPE), IEC/EN 61496-2 (Type 4, AOPDs), IEC/EN 61508-1~7 (SIL 3), IEC/EN 62061 (SIL CL 3)

01) For more information on current consumption and response time, see "2.5 Models"

02) The values of load voltage were drawn with PNP output, and in case of NPN output, apply these in reverse.

03) Be sure that the load current should be greater than 6 mA.

04) The residual voltage was drawn with 300 mA of load current.

05) It is the non-safety output. Do not use it for safety purposes.

06) In case of the KCs certified model, see "2.5.3 Hand-Body detection (SFL(A)30-□, \varnothing 30mm)."

 Note

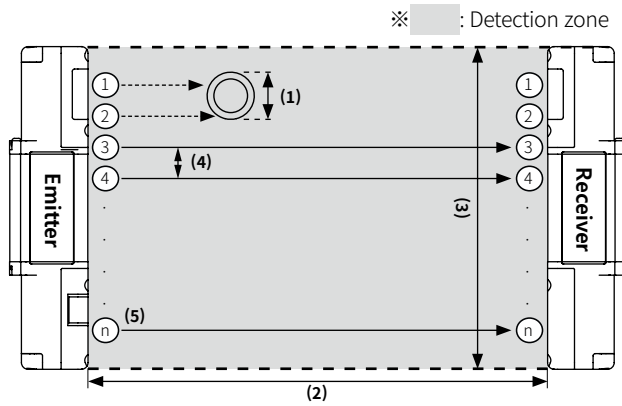

- (1) Detection capability: The minimum diameter of the detectable cylindrical object (mm).
- (2) Sensing distance: The maximum distance between the emitter and receiver that can detect an object with the minimum detection capability.
- (3) Protective height: The height at which the minimum detection object can be detected in the direction of the optical axis.
- (4) Optical axis pitch: Distance between the optical axis and the next optical axis (mm).
- (5) Number of beams: Number of optical axes that consist of the emitter and receiver. (Same as emitter and receiver)

※The gray area is the detection zone.

2.4 IEC 61508 parameters

Parameter	Explanation
Proof test interval	20 years
PFH _b (Probability of dangerous failure per hour)	1.01×10^{-8} to 9.95×10^{-9}
SFF (Safe failure fraction)	99%
HFT (Hardware fault tolerance)	1
Type of element	Type B
Failure response time	Within a response time
Safe state	OSSD 1/2 are in OFF-state

2.5 Models

2.5.1 Finger detection (SFL(A)14-□, Ø14mm)

No.	Model name		Number of beams	Protective height (mm)	Response time(ms)		Current consumption(mA)		PFH _D	MTTF _D (years)	Weight(g) ^{※2}
	SFL Series (standard type)	SFLA Series (advanced type)			T _{OFF} ^{※1}	T _{ON} ^{※1}	Emitter	Receiver			
1	SFL14-15	SFLA14-15	15	144	8.7ms	18.1ms	69mA	94mA	2.87×10 ⁻⁹	455	Approx. 400g (approx. 300g)
2	SFL14-23	SFLA14-23	23	216	9.7ms	20.6ms	71mA	97mA	3.86×10 ⁻⁹	327	Approx. 775g (approx. 585g)
3	SFL14-31	SFLA14-31	31	288	10.7ms	23.1ms	72mA	101mA	4.40×10 ⁻⁹	283	Approx. 970g (approx. 780g)
4	SFL14-39	SFLA14-39	39	360	11.7ms	25.6ms	74mA	105mA	5.07×10 ⁻⁹	242	Approx. 1.215g (approx. 975g)
5	SFL14-47	SFLA14-47	47	432	12.8ms	28.1ms	76mA	109mA	5.62×10 ⁻⁹	217	Approx. 1.410g (approx. 1.170g)
6	SFL14-55	SFLA14-55	55	504	13.8ms	30.6ms	77mA	113mA	6.29×10 ⁻⁹	192	Approx. 1.715g (approx. 1.365g)
7	SFL14-63	SFLA14-63	63	576	14.8ms	33.2ms	79mA	116mA	6.84×10 ⁻⁹	176	Approx. 1.910g (approx. 1.560g)
8	SFL14-71	SFLA14-71	71	648	15.8ms	35.7ms	80mA	120mA	7.51×10 ⁻⁹	160	Approx. 2.105g (approx. 1.755g)
9	SFL14-79	SFLA14-79	79	720	16.9ms	38.2ms	82mA	124mA	8.06×10 ⁻⁹	148	Approx. 2.300g (approx. 1.950g)
10	SFL14-87	SFLA14-87	87	792	17.9ms	40.7ms	84mA	128mA	8.73×10 ⁻⁹	136	Approx. 2.545g (approx. 2.145g)
11	SFL14-95	SFLA14-95	95	864	18.9ms	43.2ms	85mA	132mA	9.28×10 ⁻⁹	128	Approx. 2.740g (approx. 2.340g)
12	SFL14-103	SFLA14-103	103	936	19.9ms	45.7ms	87mA	135mA	9.95×10 ⁻⁹	119	Approx. 2.935g (approx. 2.535g)
13	SFL14-111	SFLA14-111	111	1,008	20.9ms	48.3ms	88mA	139mA	1.05×10 ⁻⁸	113	Approx. 3.180g (approx. 2.730g)
14		SFLA14-119	119	1,080	22.0ms	50.8ms	90mA	143mA	1.12×10 ⁻⁸	106	Approx. 3.375g (approx. 2.925g)
15		SFLA14-127	127	1,152	23.0ms	53.3ms	92mA	147mA	1.17×10 ⁻⁸	101	Approx. 3.570g (approx. 3.120g)
16		SFLA14-135	135	1,224	24.0ms	55.8ms	93mA	151mA	1.24×10 ⁻⁸	95	Approx. 5.215g (approx. 3.315g)
17		SFLA14-143	143	1,296	25.0ms	58.3ms	95mA	154mA	1.29×10 ⁻⁸	91	Approx. 5.410g (approx. 3.510g)
18		SFLA14-151	151	1,368	26.1ms	60.8ms	96mA	158mA	1.36×10 ⁻⁸	86	Approx. 5.605g (approx. 3.705g)
19		SFLA14-159	159	1,440	27.1ms	63.3ms	98mA	162mA	1.42×10 ⁻⁸	83	Approx. 5.800g (approx. 3.900g)
20		SFLA14-167	167	1,512	28.1ms	65.9ms	100mA	166mA	1.48×10 ⁻⁸	79	Approx. 6.295g (approx. 4.095g)
21		SFLA14-175	175	1,584	29.1ms	68.4ms	101mA	170mA	1.54×10 ⁻⁸	76	Approx. 6.490g (approx. 4.290g)
22		SFLA14-183	183	1,656	30.1ms	70.9ms	103mA	173mA	1.60×10 ⁻⁸	73	Approx. 6.685g (approx. 4.485g)
23		SFLA14-191	191	1,728	31.2ms	73.4ms	104mA	177mA	1.66×10 ⁻⁸	70	Approx. 6.880g (approx. 4.680g)
24		SFLA14-199	199	1,800	32.2ms	75.9ms	106mA	181mA	1.73×10 ⁻⁸	68	Approx. 7.475g (approx. 4.875g)

※1. Response time is based on when the switch is factory settings. The time may differ if the setting is changed.

※2: The weight includes packaging. The weight in parenthesis is for unit only.

※T_{OFF} - Time when OSSD output is switched from ON to OFF state

T_{ON} - Time when OSSD output is switched from OFF to ON state

(When the time of shading object in the detection zone is less than 80ms, the OSSD output remains OFF state for at least 80ms. And then it is switched to ON state.)

2.5.2 Hand detection (SFL(A)20-□, Ø20mm)

No.	Model name		Number of beams	Protective height (mm)	Response time(ms)		Current consumption(mA)		PFH _D	MTTF _D (years)	Weight(g) ^{※2}
	SFL Series (standard type)	SFLA Series (advanced type)			T _{OFF} ^{※1}	T _{ON} ^{※1}	Emitter	Receiver			
1	SFL20-12	SFLA20-12	12	183	9.3ms	19.7ms	64mA	91mA	3.23×10 ⁻⁹	398	Approx. 646g (approx. 496g)
2	SFL20-16	SFLA20-16	16	243	10.1ms	21.7ms	65mA	93mA	3.55×10 ⁻⁹	358	Approx. 808g (approx. 658g)
3	SFL20-20	SFLA20-20	20	303	11.0ms	23.8ms	67mA	95mA	4.00×10 ⁻⁹	314	Approx. 1,061g (approx. 821g)
4	SFL20-24	SFLA20-24	24	363	11.8ms	25.8ms	68mA	97mA	4.31×10 ⁻⁹	289	Approx. 1,223g (approx. 983g)
5	SFL20-28	SFLA20-28	28	423	12.6ms	27.8ms	69mA	99mA	4.76×10 ⁻⁹	260	Approx. 1,386 (approx. 1,146g)
6	SFL20-32	SFLA20-32	32	483	13.4ms	29.9ms	70mA	102mA	5.08×10 ⁻⁹	242	Approx. 1,658g (approx. 1,308g)
7	SFL20-36	SFLA20-36	36	543	14.2ms	31.9ms	71mA	104mA	5.53×10 ⁻⁹	221	Approx. 1,821g (approx. 1,471g)
8	SFL20-40	SFLA20-40	40	603	15.1ms	33.9ms	72mA	106mA	5.85×10 ⁻⁹	208	Approx. 1,983g (approx. 1,633g)
9	SFL20-44	SFLA20-44	44	663	15.9ms	36.0ms	73mA	108mA	6.29×10 ⁻⁹	193	Approx. 2,146g (approx. 1,796g)
10	SFL20-48	SFLA20-48	48	723	16.7ms	38.0ms	74mA	110mA	6.61×10 ⁻⁹	183	Approx. 2,308g (approx. 1,958g)
11	SFL20-52	SFLA20-52	52	783	17.5ms	40.0ms	75mA	113mA	7.06×10 ⁻⁹	171	Approx. 2,521g (approx. 2,121g)
12	SFL20-56	SFLA20-56	56	843	18.4ms	42.1ms	76mA	115mA	7.38×10 ⁻⁹	163	Approx. 2,683g (approx. 2,283g)
13	SFL20-60	SFLA20-60	60	903	19.2ms	44.1ms	78mA	117mA	7.82×10 ⁻⁹	153	Approx. 2,846g (approx. 2,446g)
14	SFL20-64	SFLA20-64	64	963	20.0ms	46.1ms	79mA	119mA	8.14×10 ⁻⁹	147	Approx. 3,008g (approx. 2,608g)
15	SFL20-68	SFLA20-68	68	1,023	20.8ms	48.2ms	80mA	121mA	8.59×10 ⁻⁹	139	Approx. 3,221g (approx. 2,771g)
16		SFLA20-72	72	1,083	21.6ms	50.2ms	81mA	124mA	8.91×10 ⁻⁹	134	Approx. 3,383g (approx. 2,933g)
17		SFLA20-76	76	1,143	22.5ms	52.2ms	82mA	126mA	9.35×10 ⁻⁹	127	Approx. 3,546g (approx. 3,096g)
18		SFLA20-80	80	1,203	23.3ms	54.3ms	83mA	128mA	9.67×10 ⁻⁹	123	Approx. 3,708g (approx. 3,258g)
19		SFLA20-84	84	1,263	24.1ms	56.3ms	84mA	130mA	1.01×10 ⁻⁸	117	Approx. 5,321g (approx. 3,421g)
20		SFLA20-88	88	1,323	24.9ms	58.3ms	85mA	132mA	1.04×10 ⁻⁸	113	Approx. 5,483g (approx. 3,583g)
21		SFLA20-92	92	1,383	25.7ms	60.4ms	86mA	135mA	1.09×10 ⁻⁸	109	Approx. 5,646g (approx. 3,746g)
22		SFLA20-96	96	1,443	26.6ms	62.4ms	87mA	137mA	1.12×10 ⁻⁸	105	Approx. 5,808g (approx. 3,908g)
23		SFLA20-100	100	1,503	27.4ms	64.4ms	89mA	139mA	1.16×10 ⁻⁸	101	Approx. 6,271g (approx. 4,071g)
24		SFLA20-104	104	1,563	28.2ms	66.5ms	90mA	141mA	1.20×10 ⁻⁸	98	Approx. 6,433g (approx. 4,233g)
25		SFLA20-108	108	1,623	29.0ms	68.5ms	91mA	143mA	1.24×10 ⁻⁸	95	Approx. 6,596g (approx. 4,396g)
26		SFLA20-112	112	1,683	29.8ms	70.5ms	92mA	146mA	1.27×10 ⁻⁸	92	Approx. 6,758g (approx. 4,558g)
27		SFLA20-116	116	1,743	30.7ms	72.6ms	93mA	148mA	1.32×10 ⁻⁸	89	Approx. 7,321g (approx. 4,721g)
28		SFLA20-120	120	1,803	31.5ms	74.6ms	94mA	150mA	1.35×10 ⁻⁸	87	Approx. 7,483g (approx. 4,883g)
29		SFLA20-124	124	1,863	32.3ms	76.6ms	95mA	152mA	1.39×10 ⁻⁸	84	Approx. 7,646g (approx. 5,046g)

※1. Response time is based on when the switch is factory settings. The time may differ if the setting is changed.

※2: The weight includes packaging. The weight in parenthesis is for unit only.

※T_{OFF} - Time when OSSD output is switched from ON to OFF state

T_{ON} - Time when OSSD output is switched from OFF to ON state

(When the time of shading object in the detection zone is less than 80ms, the OSSD output remains OFF state for at least 80ms. And then it is switched to ON state.)

2.5.3 Hand-Body detection (SFL(A)30-□, Ø30mm)

No.	Model name		Number of beams	Protective height (mm)	Response time(ms)		Current consumption(mA)		PFH _D	MTTFd (years)	Weight(g) ^{※2}
	SFL Series (standard type)	SFLA Series (advanced type)			T _{OFF} ^{※1}	T _{ON} ^{※1}	Emitter	Receiver			
1		SFLA30-9	9	218	8.8ms	18.5ms	64mA	91mA	3.06×10 ⁻⁹	423	Approx. 780g (approx. 590g)
2		SFLA30-12	12	293	9.5ms	20.1ms	65mA	93mA	3.32×10 ⁻⁹	386	Approx. 1,034g (approx. 794g)
3		SFLA30-15	15	368	10.1ms	21.7ms	67mA	95mA	3.71×10 ⁻⁹	341	Approx. 1,237g (approx. 997g)
4		SFLA30-18	18	443	10.8ms	23.4ms	68mA	97mA	3.97×10 ⁻⁹	316	Approx. 1,550g (approx. 1,200g)
5		SFLA30-21	21	518	11.4ms	25.0ms	69mA	99mA	4.36×10 ⁻⁹	285	Approx. 1,753g (approx. 1,403g)
6		SFLA30-24	24	593	12.1ms	26.6ms	70mA	102mA	4.63×10 ⁻⁹	268	Approx. 1,956g (approx. 1,606g)
7		SFLA30-27	27	668	12.7ms	28.2ms	71mA	104mA	5.02×10 ⁻⁹	245	Approx. 2,159g (approx. 1,809g)
8		SFLA30-30	30	743	13.4ms	29.8ms	72mA	106mA	5.28×10 ⁻⁹	232	Approx. 2,412g (approx. 2,012g)
9		SFLA30-33 ^{※3}	33	818	14.0ms	31.4ms	73mA	108mA	5.67×10 ⁻⁹	215	Approx. 2,615g (approx. 2,215g)
10		SFLA30-36 ^{※3}	36	893	14.7ms	33.0ms	74mA	110mA	5.93×10 ⁻⁹	205	Approx. 2,819g (approx. 2,419g)
11		SFLA30-39 ^{※3}	39	968	15.3ms	34.6ms	75mA	113mA	6.32×10 ⁻⁹	192	Approx. 3,072g (approx. 2,622g)
12	SFL30-42	SFLA30-42	42	1,043	16.0ms	36.2ms	76mA	115mA	6.58×10 ⁻⁹	184	Approx. 3,275g (approx. 2,825g)
13	SFL30-45	SFLA30-45	45	1,118	16.6ms	37.8ms	78mA	117mA	6.97×10 ⁻⁹	173	Approx. 3,478g (approx. 3,028g)
14	SFL30-48	SFLA30-48	48	1,193	17.3ms	39.4ms	79mA	119mA	7.23×10 ⁻⁹	166	Approx. 3,681g (approx. 3,231g)
15	SFL30-51	SFLA30-51	51	1,268	17.9ms	41.1ms	80mA	121mA	7.62×10 ⁻⁹	157	Approx. 5,334g (approx. 3,434g)
16	SFL30-54	SFLA30-54	54	1,343	18.6ms	42.7ms	81mA	124mA	7.88×10 ⁻⁹	152	Approx. 5,537g (approx. 3,637g)
17	SFL30-57	SFLA30-57	57	1,418	19.2ms	44.3ms	82mA	126mA	8.27×10 ⁻⁹	144	Approx. 5,740g (approx. 3,840g)
18	SFL30-60	SFLA30-60	60	1,493	19.9ms	45.9ms	83mA	128mA	8.54×10 ⁻⁹	140	Approx. 5,944g (approx. 4,044g)
19	SFL30-63	SFLA30-63	63	1,568	20.5ms	47.5ms	84mA	130mA	8.93×10 ⁻⁹	133	Approx. 6,447g (approx. 4,247g)
20	SFL30-66	SFLA30-66	66	1,643	21.2ms	49.1ms	85mA	132mA	9.19×10 ⁻⁹	129	Approx. 6,650g (approx. 4,450g)
21	SFL30-69	SFLA30-69	69	1,718	21.8ms	50.7ms	86mA	135mA	9.58×10 ⁻⁹	124	Approx. 6,853g (approx. 4,653g)
22	SFL30-72	SFLA30-72	72	1,793	22.5ms	52.3ms	87mA	137mA	9.84×10 ⁻⁹	120	Approx. 7,056g (approx. 4,856g)
23	SFL30-75	SFLA30-75	75	1,868	23.1ms	53.9ms	89mA	139mA	1.02×10 ⁻⁸	116	Approx. 7,659g (approx. 5,059g)

※1. Response time is based on when the switch is factory settings. The time may differ if the setting is changed.

※2: The weight includes packaging. The weight in parenthesis is for unit only.

※3: KCs certified products.

※T_{OFF} - Time when OSSD output is switched from ON to OFF state

T_{ON} - Time when OSSD output is switched from OFF to ON state

(When the time of shading object in the detection zone is less than 80ms, the OSSD output remains OFF state for at least 80ms. And then it is switched to ON state.)

2.5.4 How to calculate the response time (RT) for the series connection

Number of SET	Response time (ms)
2 SET	SET 1 RT + SET 2 RT
3 SET	SET 1 RT + SET 2 RT + SET 3 RT + 1ms
4 SET	SET 1 RT + SET 2 RT + SET 3 RT + SET 4 RT + 2ms

(1) 4 SET series connection (SFL(A)14-□, Ø14mm)

- Connected light curtains: (SET 1 - SFLA14-15, SET 2 - SFLA14-15, SET 3 - SFLA14-103, SET 4 - SFLA14-111)
- Total response time(T_{OFF}): 8.7ms + 8.7ms + 19.9ms + 20.9ms + 2ms = 60.2ms
- Total response time(T_{ON}): 18.1ms + 18.1ms + 45.7ms + 48.3ms + 2ms = 132.2ms

(2) 4 SET series connection (SFL(A)20-□, Ø20mm)

- Connected light curtains: (SET 1 - SFLA20-12, SET 2 - SFLA20-12, SET 3 - SFLA20-60, SET 4 - SFLA20-72)
- Total response time(T_{OFF}): 9.3ms + 9.3ms + 19.2ms + 21.6ms + 2ms = 61.4ms
- Total response time(T_{ON}): 19.7ms + 19.7ms + 44.1ms + 50.2ms + 2ms = 135.7ms

(3) 4 SET series connection (SFL(A)30-□, Ø30mm)

- Connected light curtains: (SET 1 - SFLA30-9, SET 2 - SFLA30-9, SET 3 - SFLA30-36, SET 4 - SFLA30-42)
- Total response time(T_{OFF}): 8.8ms + 8.8ms + 14.7ms + 16ms + 2ms = 50.3ms
- Total response time(T_{ON}): 18.5ms + 18.5ms + 33ms + 36.2ms + 2ms = 108.2ms

(4) 3 SET series connection of the standard type

- Connected light curtains: (SET 1 - SFL30-75, SET 2 - SFL30-75, SET 3 - SFL30-75)
- Total response time(T_{OFF}): 23.1ms + 23.1ms + 23.1ms + 1ms = 70.3ms
- Total response time(T_{ON}): 53.9ms + 53.9ms + 53.9ms + 1ms = 162.7ms

(5) 4 SET series connection of the advanced type

- Connected light curtains: (SET 1 - SFLA20-124, SET 2 - SFLA20-124, SET 3 - SFLA20-124, SET 4 - SFLA20-28)
- Total response time(T_{OFF}): 32.3ms + 32.3ms + 32.3ms + 12.6ms + 2ms = 111.5ms
- Total response time(T_{ON}): 76.6ms + 76.6ms + 76.6ms + 27.8ms + 2ms = 259.6ms

3. Dimensions

3.1 Emitter / Receiver

3.1.1 Fingter detection (Ø14mm)

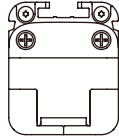

(unit: mm)

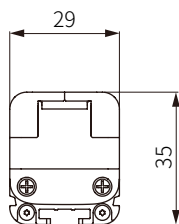
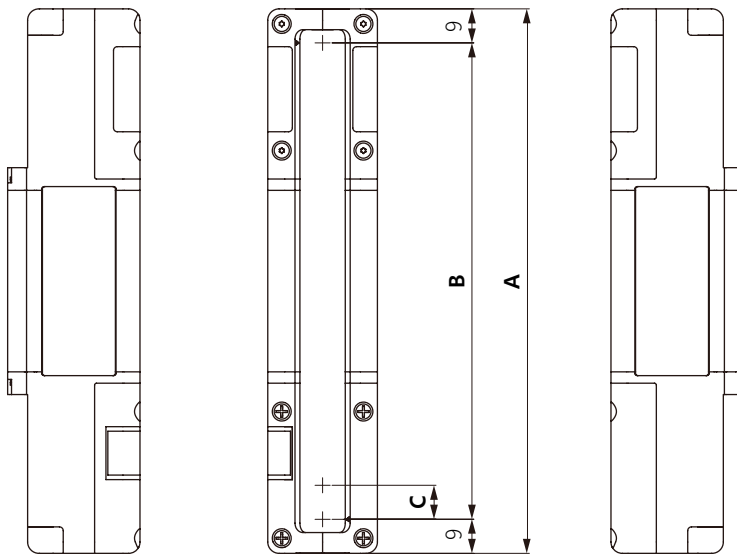

No.	Model name		Number of beams	A	B	C
	SFL Series (standard type)	SFLA Series (advanced type)		Protective height	Sensing height	Optical axis pitch
1	SFL14-15	SFLA14-15	15	144	126	9
2	SFL14-23	SFLA14-23	23	216	198	
3	SFL14-31	SFLA14-31	31	288	270	
4	SFL14-39	SFLA14-39	39	360	342	
5	SFL14-47	SFLA14-47	47	432	414	
6	SFL14-55	SFLA14-55	55	504	486	
7	SFL14-63	SFLA14-63	63	576	558	
8	SFL14-71	SFLA14-71	71	648	630	
9	SFL14-79	SFLA14-79	79	720	702	
10	SFL14-87	SFLA14-87	87	792	774	
11	SFL14-95	SFLA14-95	95	864	846	
12	SFL14-103	SFLA14-103	103	936	918	
13	SFL14-111	SFLA14-111	111	1,008	990	
14		SFLA14-119	119	1,080	1,062	
15		SFLA14-127	127	1,152	1,134	
16		SFLA14-135	135	1,224	1,206	
17		SFLA14-143	143	1,296	1,278	
18		SFLA14-151	151	1,368	1,350	
19		SFLA14-159	159	1,440	1,422	
20		SFLA14-167	167	1,512	1,494	
21		SFLA14-175	175	1,584	1,566	
22		SFLA14-183	183	1,656	1,638	
23		SFLA14-191	191	1,728	1,710	
24		SFLA14-199	199	1,800	1,782	

3.1.2 Hand detection (Ø20mm)

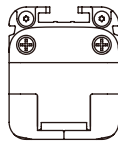

(unit: mm)

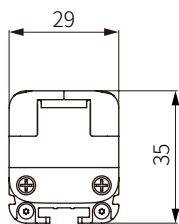
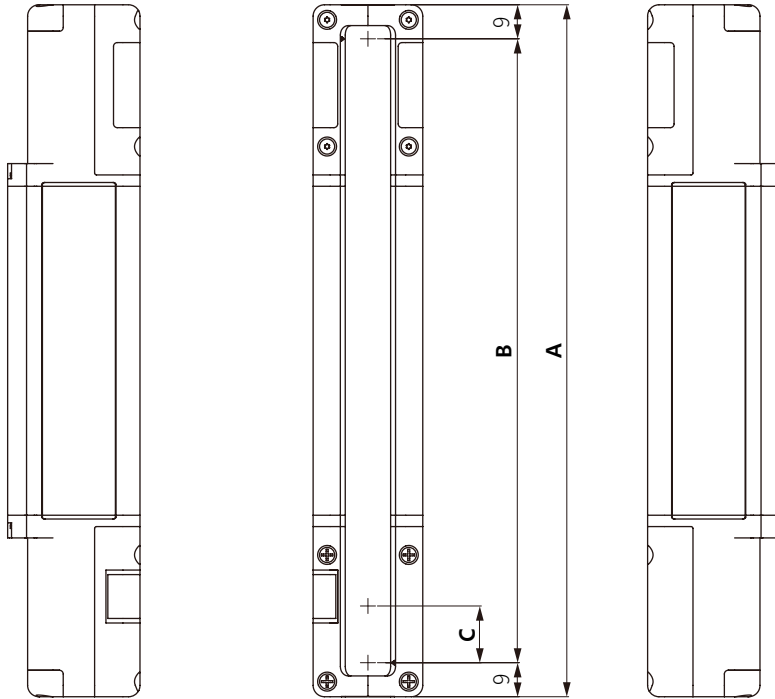

No.	Model name		Number of beams	A	B	C
	SFL Series (standard type)	SFLA Series (advanced type)		Protective height	Sensing height	Optical axis pitch
1	SFL20-12	SFLA20-12	12	183	165	15
2	SFL20-16	SFLA20-16	16	243	225	
3	SFL20-20	SFLA20-20	20	303	285	
4	SFL20-24	SFLA20-24	24	363	345	
5	SFL20-28	SFLA20-28	28	423	405	
6	SFL20-32	SFLA20-32	32	483	465	
7	SFL20-36	SFLA20-36	36	543	525	
8	SFL20-40	SFLA20-40	40	603	585	
9	SFL20-44	SFLA20-44	44	663	645	
10	SFL20-48	SFLA20-48	48	723	705	
11	SFL20-52	SFLA20-52	52	783	765	
12	SFL20-56	SFLA20-56	56	843	825	
13	SFL20-60	SFLA20-60	60	903	885	
14	SFL20-64	SFLA20-64	64	963	945	
15	SFL20-68	SFLA20-68	68	1,023	1,005	
16	\	SFLA20-72	72	1,083	1,065	
17		SFLA20-76	76	1,143	1,125	
18		SFLA20-80	80	1,203	1,185	
19		SFLA20-84	84	1,263	1,245	
20		SFLA20-88	88	1,323	1,305	
21		SFLA20-92	92	1,383	1,365	
22		SFLA20-96	96	1,443	1,425	
23		SFLA20-100	100	1,503	1,485	
24		SFLA20-104	104	1,563	1,545	
25		SFLA20-108	108	1,623	1,605	
26		SFLA20-112	112	1,683	1,665	
27		SFLA20-116	116	1,743	1,725	
28		SFLA20-120	120	1,803	1,785	
29		SFLA20-124	124	1,863	1,845	

3.1.3 Hand - Body detection (Ø30mm)

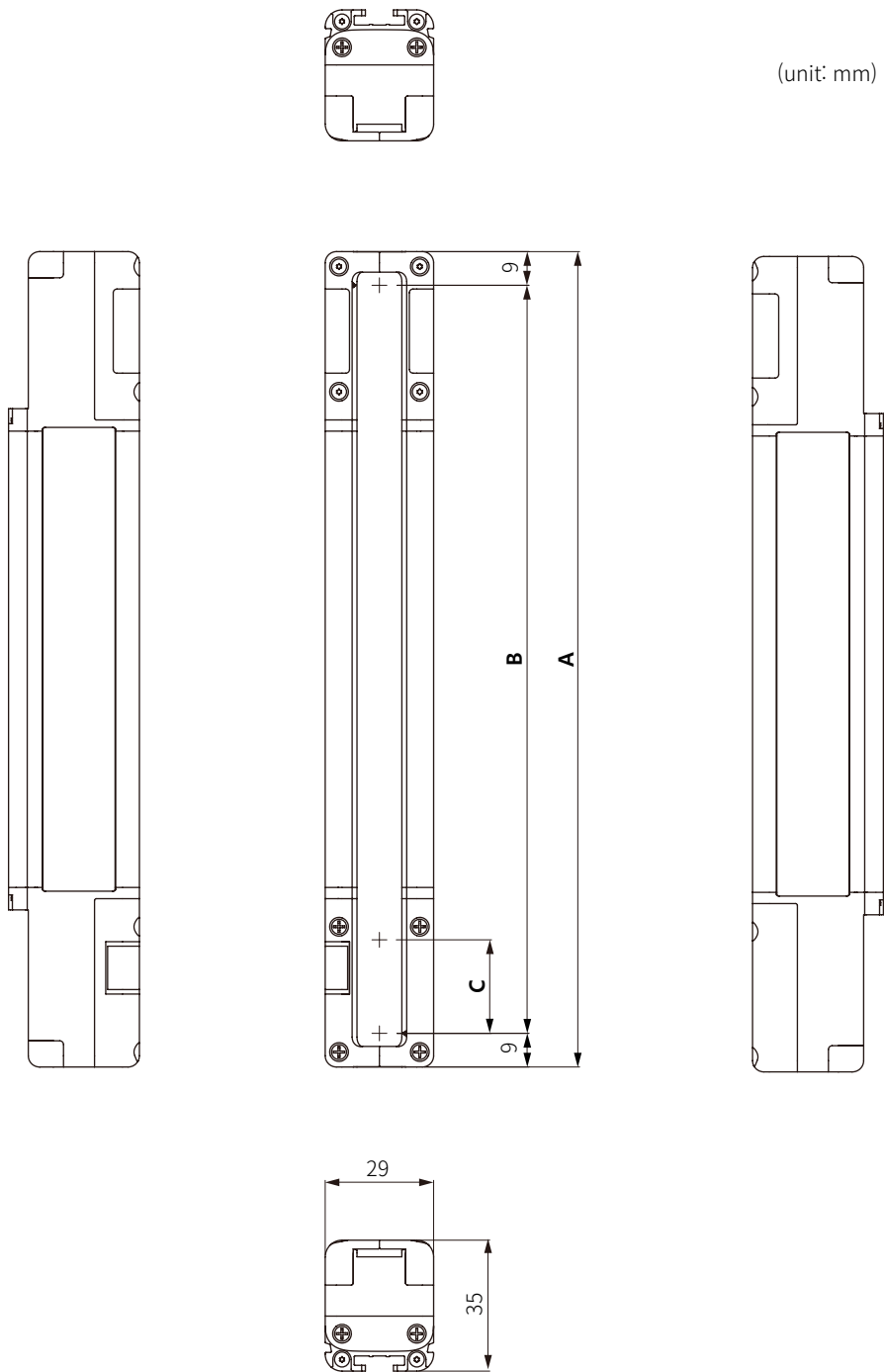

No.	Model name		Number of beams	A	B	C
	SFL Series (standard type)	SFLA Series (advanced type)		Protective height	Sensing height	Optical axis pitch
1		SFLA30-9	9	218	200	25
2		SFLA30-12	12	293	275	
3		SFLA30-15	15	368	350	
4		SFLA30-18	18	443	425	
5		SFLA30-21	21	518	500	
6		SFLA30-24	24	593	575	
7		SFLA30-27	27	668	650	
8		SFLA30-30	30	743	725	
9		SFLA30-33	33	818	800	
10		SFLA30-36	36	893	875	
11		SFLA30-39	39	968	950	
12	SFL30-42	SFLA30-42	42	1,043	1,025	
13	SFL30-45	SFLA30-45	45	1,118	1,100	
14	SFL30-48	SFLA30-48	48	1,193	1,175	
15	SFL30-51	SFLA30-51	51	1,268	1,250	
16	SFL30-54	SFLA30-54	54	1,343	1,325	
17	SFL30-57	SFLA30-57	57	1,418	1,400	
18	SFL30-60	SFLA30-60	60	1,493	1,475	
19	SFL30-63	SFLA30-63	63	1,568	1,550	
20	SFL30-66	SFLA30-66	66	1,643	1,625	
21	SFL30-69	SFLA30-69	69	1,718	1,700	
22	SFL30-72	SFLA30-72	72	1,793	1,775	
23	SFL30-75	SFLA30-75	75	1,868	1,850	

3.2 Brackets (sold separately)

Tighten the brackets screws with a torque of 0.98 N m.

3.2.1 Top/Bottom adjustable bracket (BK-SFL-TBA)

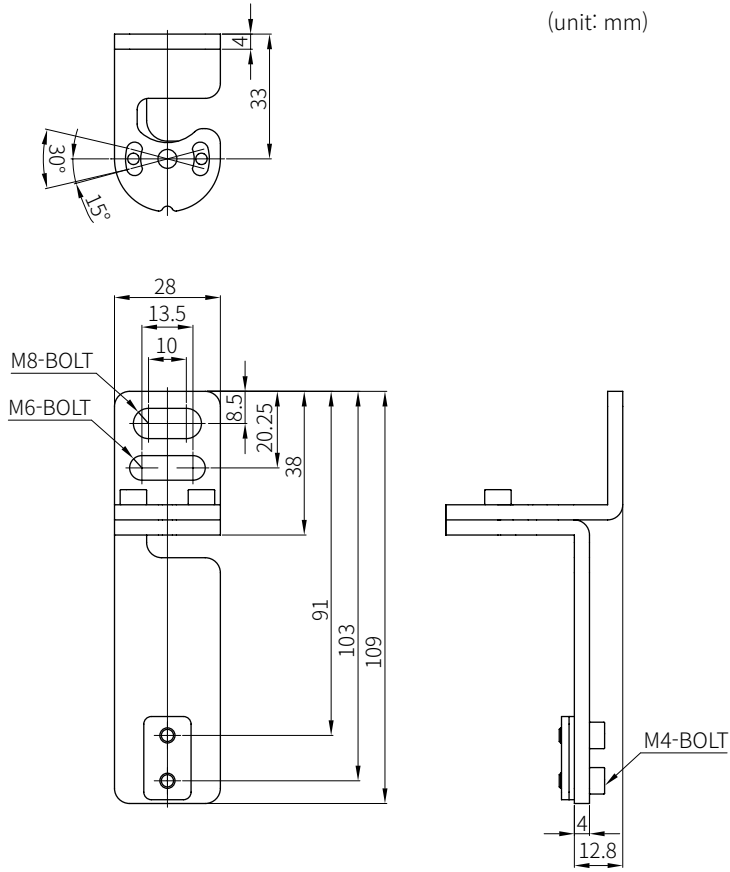

3.2.2 Top/Bottom bracket (BK-SFL-TBF)

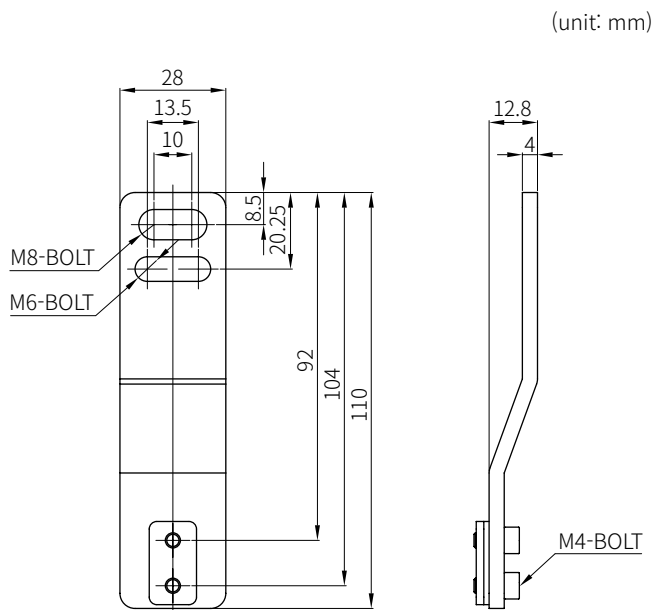

3.2.3 Side adjustable bracket (BK-SFL-SA)

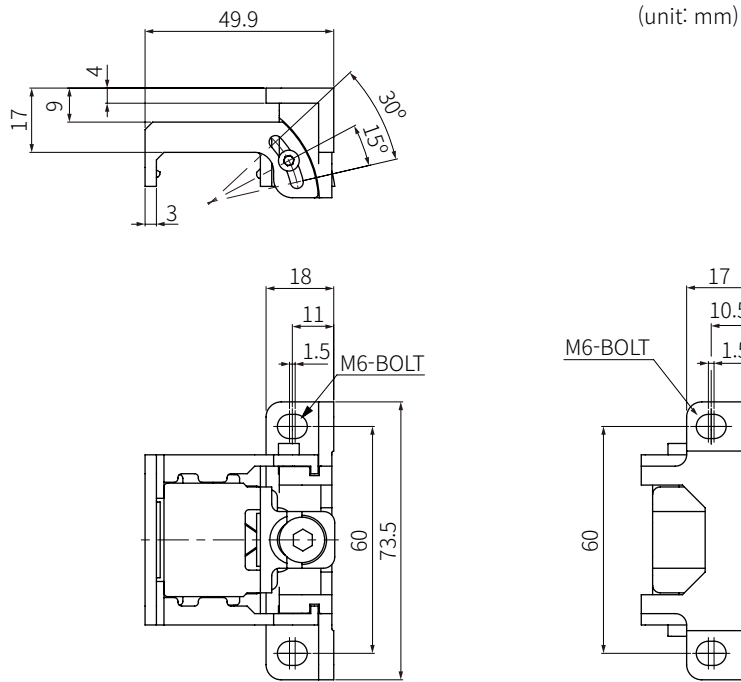

3.2.4 Side bracket (BK-SFL-SF)

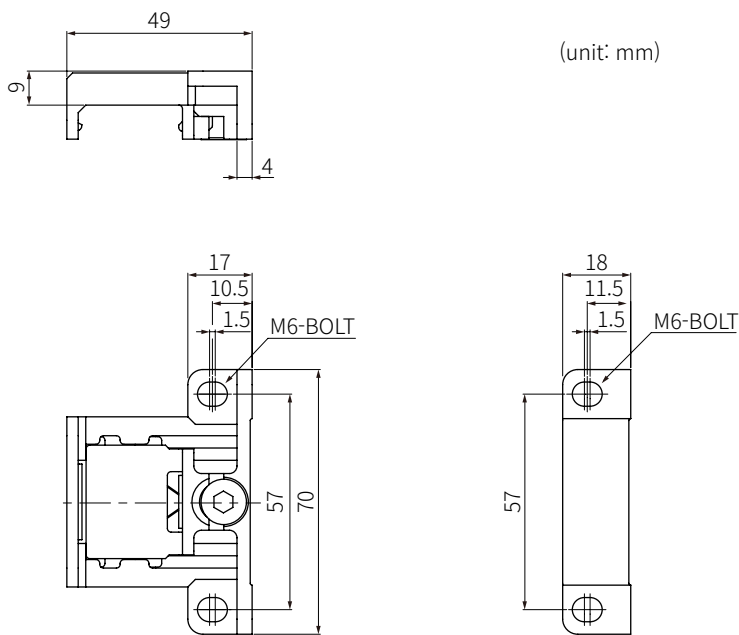

3.3 Sold separately

Tighten the connecting cable screws with a torque of 0.59 N m.

3.3.1 Power I/O cable (connector type)

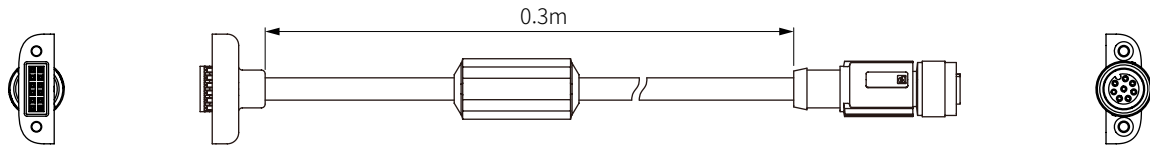

Model name		Length (L)
Emitter (black)	Receiver (black)	
SFL-BCT	SFL-BCR	0.3m

3.3.2 Power I/O cable (wire type)

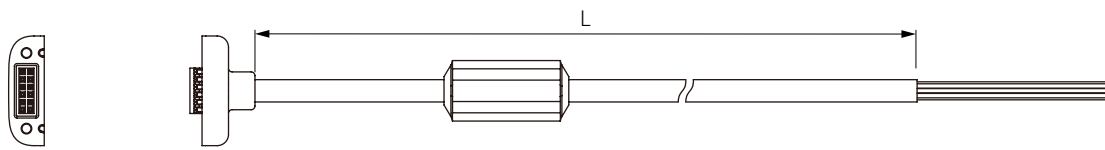

Model name		Length (L)
Emitter (black)	Receiver (black)	
SFL-C3T	SFL-C3R	3m
SFL-C7T	SFL-C7R	7m
SFL-C10T	SFL-C10R	10m
SFL-C15T	SFL-C15R	15m

※ See the connector cable (socket type) for the color of wire.

3.3.3 Connector cable (socket type)

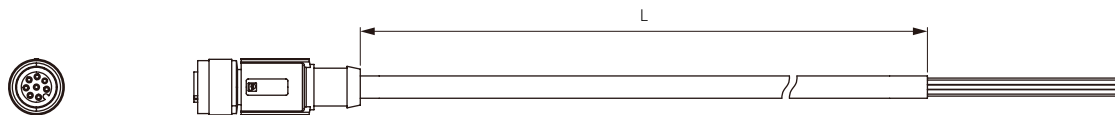

Model name		Length (L)
Emitter (black)	Receiver (black)	
CID8-3T	CID8-3R	3m
CID8-5T	CID8-5R	5m
CID8-7T	CID8-7R	7m
CID8-10T	CID8-10R	10m

Pin no.	Color	Model name	
		Emitter (black)	Receiver (black)
1	Blue	0V	0V
2	Orange	Reset hold input / Mute 1 input	EDM input
3	Yellow	RS485(B)	RS485(B)
4	Red	RS485(A)	RS485(A)
5	Pink	AUX 2 output / Mute 2 input	AUX 1 output
6	Black	External test input	OSSD 1 output
7	White	Reset input	OSSD 2 output
8	Brown	+24VDC	+24VDC

3.3.4 Connector cable (socket-plug type)

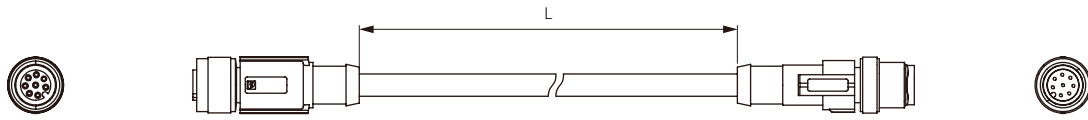

Model name		Length (L)
Emitter (black)	Receiver (black)	
C1D8-3T	C1D8-3R	3m
C1D8-5T	C1D8-5R	5m
C1D8-7T	C1D8-7R	7m
C1D8-10T	C1D8-10R	10m
C1D8-15T	C1D8-15R	15m
C1D8-20T	C1D8-20R	20m

※ See the connector cable (socket type) for pin no. and color.

3.3.5 Series connection cable

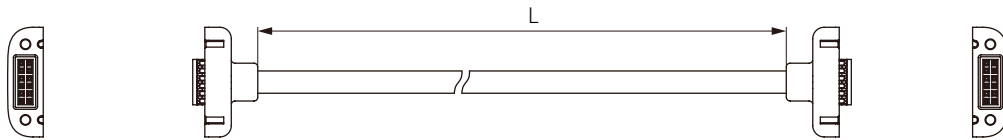

Model name		Length (L)
Emitter (black)	Receiver (black)	
SFL-EC03T	SFL-EC03R	0.3m
SFL-EC3T	SFL-EC3R	3m
SFL-EC7T	SFL-EC7R	7m
SFL-EC10T	SFL-EC10R	10m

3.3.6 Lamp output cable

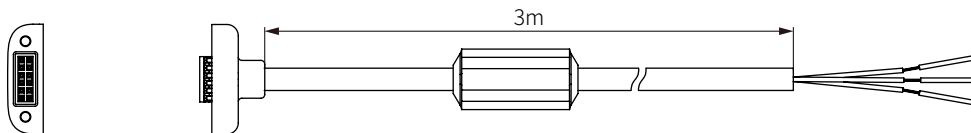

Model name	Length (L)
SFL-LC	3m

Color	Function
Blue	0V
Brown	+24VDC
Black	Lamp output

3.3.7 USB/Serial communication converter

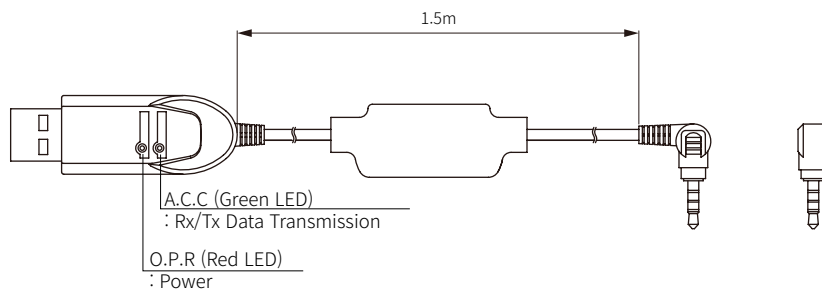

Model name	Length (L)
SCM-US	1.5m

3.3.8 SFL / SFLA dedicated converter cable

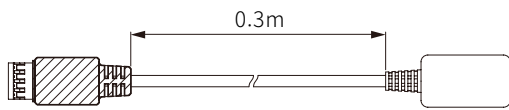

Model name	Length (L)
EXT-SFL	0.3m

3.3.9 Test piece

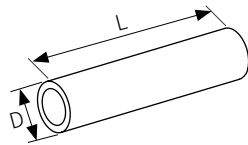

Model name	Diameter(D)	Length(L)
SFL-T14	Ø14mm	200mm
SFL-T20	Ø20mm	
SFL-T30	Ø30mm	

※The test piece is a black opaque object.

3.4 Unit descriptions

(1) Front part

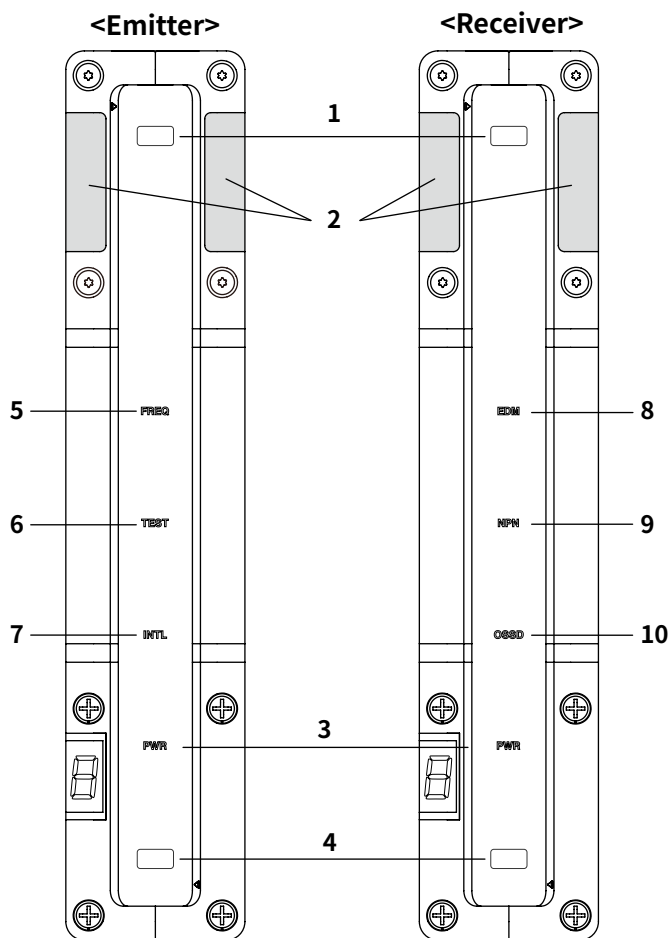

[Common]

1. **Top beam indicator:** It lights up when the top beams are in the normal state without interruption.
2. **Upper OSSD indicator:** It lights up or flashes depending on the OSSD outputs.
3. **Power/Lockout indicator (PWR):** It lights up when the light curtains are powered up.
4. **Bottom beam indicator:** It lights up when the bottom beams are in the normal state without interruption.

[Emitter]

5. **Frequency indicator (FREQ):** When using mutual interference prevention, it shows the frequency you set.
6. **External test indicator (TEST):** It lights up when the external test signal is applied.
7. **Interlock indicator (INTL):** It lights up when entering to the interlock.

[Receiver]

8. **EDM indicator (EDM):** It lights up when EDM input is on.
9. **NPN/PNP indicator (NPN):** It lights up in the NPN and is turned off in the PNP.
10. **OSSD indicator (OSSD):** It lights up in green when the OSSD outputs are in the ON state, and in red when the OSSD outputs are in the OFF state.

※For more information on the indicators, see "3.4.1 Status indicators".

(2) Front part - When removing the cover

Tighten the cover screws on the front part with a torque of 0.59 N m.

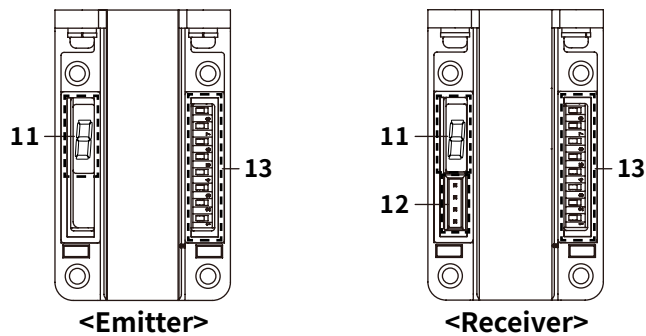

11. 7-Segment display: It shows the status of light curtain.

※For more information on the indicators, see "3.4.2 7-Segment display".

12. PC communication port: Insert the converter cable and connect to the USB/Serial communication converter.

13. Setting switch: You can set the function.

※For more information on the setting switch, see "3.4.3 Setting switch".

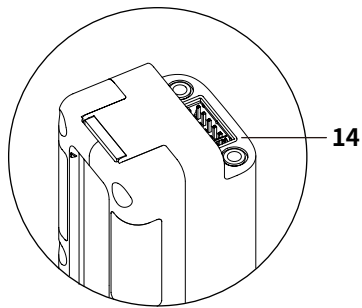
(3) Upper part**14. Lamp output terminal**

: It is located on the top of the emitter and receiver. Insert the lamp output cable and connect the external output indicator. Tighten the end cap screws with a torque of 0.59 N m.

In case of the series connection, use dedicated series connection cable to connect light curtains.

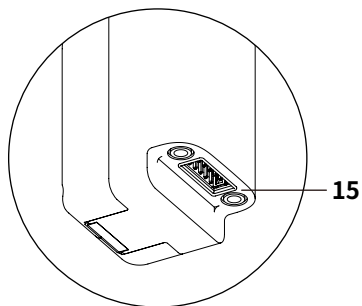
(4) Bottom part**15. Power supply terminal**

: It is located on the bottom of the emitter and receiver. Insert the power I/O cable for power supply. Tighten the end cap screws with a torque of 0.59 N m.

In case of the series connection, use dedicated series connection cable to connect light curtains.

3.4.1 Status indicators

Position	Indicator	Color	Operation	Description
Emitter/ Receiver	1. Top beam indicator	Blue	ON	Top beam is clear (\geq Incident light level 30 %)
			Flashing	Top beam is unstable (Incident light level: 15 to 35 % ^{※1})
			OFF	Top beam is blocked (\leq Incident light level 15 %)
	2. Upper OSSD indicator	Green	ON	OSSD is ON
			Flashing	Muting or override function is activated.
		Red	ON	OSSD is OFF
			Flashing	Enter lockout condition
	3. Power/Lockout indicator (PWR)	Green	ON	Normal operation
			Flashing	Warning condition
			OFF	No power
	4. Bottom beam indicator	Blue	ON	Bottom beam is clear. (\geq Incident light level 30 %)
			Flashing	Bottom beam is unstable. (Incident light level: 15 to 35 % ^{※1})
OFF			Bottom beam is blocked. (\leq Incident light level 15 %)	
Red		Flashing	Interruption of disturbance light	
Emitter	5. Frequency indicator (FREQ)	Green	ON	Set frequency B
			OFF	Set frequency A
	6. External test indicator (TEST)	Green	ON	External test input is ON state.
			OFF	External test input is OFF state.
	7. Interlock indicator (INTL)	Yellow	ON	Interlock condition
			Flashing	Reset-hold condition
OFF			Release interlock condition	
Receiver	8. EDM indicator (EDM)	Green	ON	EDM input is ON state.
			Flashing	EDM error ^{※2}
			OFF	EDM input is OFF state or EDM is deactivated.
	9. NPN/PNP indicator (NPN)	Green	ON	NPN output
			OFF	PNP output
	10. OSSD indicator (OSSD)	Green	ON	OSSD is ON
Red		ON	OSSD is OFF	

※1: It flashes if the amount of received light on the top or bottom beam decreases less than from 15 to 35%, and lasts for more than 30 minutes.

※2: The light curtain enters the lockout condition. For more information on error and warnings, see "11. Troubleshooting".

※In series connection, the indicators all but OSSD indicators at top and bottom are displayed based on the master status of the receiver. You can check error and warnings saved for each set via the dedicated software (atLightCurtain).

※The indicator flashes every 1 second.

3.4.2 7-Segment display

(1) Upon power on

- When the power is on, [P] is displayed to the segment LEDs of emitter and receiver.
- The segment LEDs are turned off during the self-test.
- When the self-test completes, see "(2) During operation."
- When an error occurs during the self-test, see "(3) During error condition."

(2) During operation

The operation status is displayed in the following order of priority.

Position	Operation	Display		Description
Emitter/ Receiver	PC connection (download)	P	Flashing	Flashes when downloading the setting information.
	Error condition	E	Flashing	Flashes when entering the lockout condition.
	Communication error	C	Flashing	Flashes when RS485 communication error occurs.
	Warning condition	A	Flashing	Flashes when in a warning condition.
Emitter	Default condition	0	ON	Displays when function is deactivated.
	Blanking	b	ON	Displays when the blanking function is activated.
	Muting	n̄	ON	Displays when in the muting state.
	Override	o	ON	Displays when in the override state.
	Reset-hold	H	ON	Displays when waiting for reset-hold input.
	Reduced resolution	r	ON	Displays when the reduced resolution function is activated.
Receiver	Light incident	9	ON	Displays the sensitivity level of beams with the lowest light incident (from 0 to 9 level).

(3) During error condition

When entering lockout condition or warning condition, codes are displayed every 2 seconds based on the following order.

- Error code [E] or warning code [A]
- 1 level of error or warning code [0 to 9]
- 2 level of error or warning code [0 to 9]
- After turning off, repeat i, ii, and iii.



※In series connection, the segment indicators all but light incident display are displayed based on the master status of the emitter and receiver. However, when an error or warning occurs, all connected light curtains enter the lockout state. And the relevant condition is displayed at the segment LEDs of the light curtain that has the error.

※For more information on error and warnings, see "11. Troubleshooting".

3.4.3 Setting switch

You can set functions via the setting switch. Be sure to select the same settings of emitter and receiver to activate the functions. All factory defaults are OFF state.

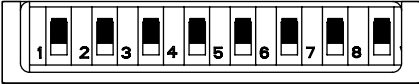
Setting switch	No.	Function	Settings (marks in sticker)	
			ON	OFF(factory default)
	1	Select NPN or PNP	NPN	PNP
	2	Sensing distance	Short (S)	Long (L)
	3	Select Frequency A or B	Frequency B (FREQ B)	Frequency A (FREQ A)
	4	Reset-hold	Reset-hold (R-H)	Deactivated (OFF)
	5	Interlock	Manual reset (MAN)	Auto reset (AUTO)
	6	EDM	EDM	Deactivated (OFF)
	7	Muting	MUTE	Deactivated (OFF)
	8	Apply settings	atLightCurtain (PC)	Setting switch (SW)



Note

When you change the switch settings, keep the following points in mind.

- Be sure to complete the settings before applying the power. When the switch settings is changed during operation, light curtain enters lockout condition because of switch error.
- When the reset hold switch and muting switch are in ON state at the same time, they enter the lockout condition.
- When the switch settings of muting is ON position, the auxiliary output 2 (AUX 2) is deactivated.
- When the switch settings of applying setting is OFF position, the switch settings are applied to the light curtain. If it is ON position, the settings of atLightCurtain is applied to the light curtain. The switch settings are ignored.
- In case of SFL (standard type), the position 8 of the setting switch is always OFF.

※For more information on error and warnings, see "11. Troubleshooting".

4. General functions

4.1 Mode and state

Status	Description
Power on	It is the initial entry after power on. Self-test is performed and the OSSD output remains OFF state.
OSSD ON	All beams are clear when there is no object in the detection zone. The OSSD output goes to ON state within the response time or remains ON state.
OSSD OFF	Certain beams are blocked when there is an object in the detection zone. The OSSD output goes to OFF state within the response time or remains OFF state.
Lockout state	It enters when an error occurs during operation or self-test. The OSSD output goes to OFF state within the response time or remains OFF state. When the lockout reset input is applied or power is supplied again, the lockout condition is released.
Setting state	It is for downloading the setting information after connecting the dedicated software (atLightCurtain). The OSSD output goes to OFF state within the response time or remains OFF state. When the download completes, the light curtain performs self-test again and release the setting state.

4.2 Self-test

This function diagnoses an internal error of the light curtain.

Self-test is performed once within 2 seconds when power is on. Periodic self-test is performed during operation; it completes within the response time. The error is displayed on the status indicators and 7-segment LEDs.

※For more information on error and warnings, see "11. Troubleshooting".

(1) Inspection items of emitter

- CPU
- Power
- External wiring input
- Light emitting circuit
- Setting switch
- Memory
- Communication
- Configuration of product connection
- Lamp 2 output (when connected)

(2) Inspection items of receiver

- CPU
- Power
- External wiring input
- Light receiving circuit
- Setting switch
- Memory
- Communication
- Configuration of product connection
- Lamp 1 output (when connected)
- Setting information

4.3 Alarm for incident light level

The received signal is divided into three areas (stable light ON, unstable light ON, and stable light OFF) based on the light incident level as follows. The light incident level determines either OSSD output is ON or OFF and the OSSD indicators display the condition. And 7-segment indicator displays the level of the lowest light receiving beam (0 to 9 levels).

The amount of received light may decrease due to the product distortion or long-term use.

If the amount of received light, even one beam, decreases less than from 15 to 35% and lasts for more than 30 minutes, the alarm for the sensitivity reduction occurs.

Set the output mode of auxiliary output or lamp output to "sensitivity reduction."

For more information on the auxiliary output, see "6.5 Auxiliary output (AUX 1/2)", "6.6 Lamp output (Lamp 1/2)"

For more information on error and warnings, see "11. Troubleshooting".

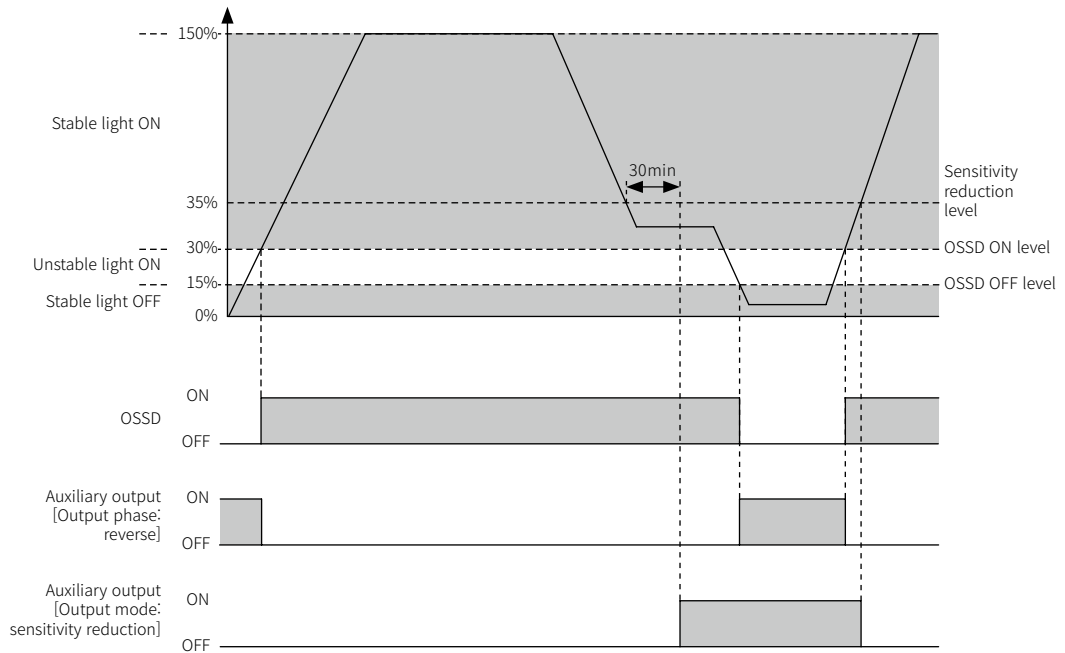

Note

For the sensitivity level based on the incident light level, see the table below.

Sensitivity level	Incident light level(%)
0	0
1	15 to 30
2	30 to 45
3	45 to 60
4	60 to 75
5	75 to 90
6	90 to 105
7	105 to 121
8	121 to 135
9	135 to 150

4.4 OSSD output

Each of the two OSSD outputs in the receiver generates an output signal. And the output monitor each other to monitor the output state.

In addition, each output signal checks its patterns to improve diagnostic reliability.

As shown in the figure below, when OSSD is in ON state, it periodically switches to OFF state for output circuit test.

If the timing patterns by the feedback signal are correct, it is interpreted as normal.

(1) Normal pattern timing chart

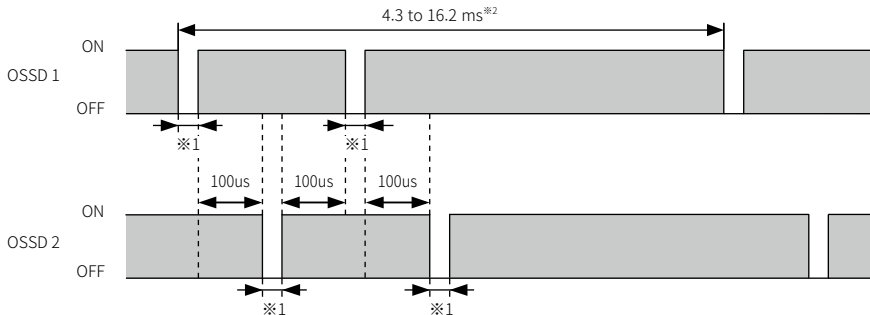

※1: It can be increased from 50us to 300us based on the connected load (e.g. capacitive load).

※2: It may differ depending on the series connection.

(2) Abnormal pattern timing chart

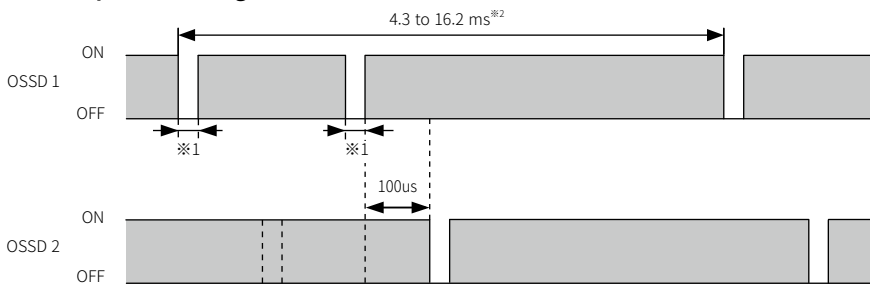

※1: It can be increase from 50us to 300us based on the connected load (e.g. capacitive load).

※2: It may differ depending on the series connection.

※If the pattern timing by the feedback signal is incorrect due to overcurrent or short-circuit of the output cable, light curtain enters lockout condition due to incorrect wiring or internal circuit damage of OSSD. Make sure that devices connected to the OSSD do not respond to any OFF signal from self-diagnosis.

※For more information on error and warnings, see "11. Troubleshooting".

4.5 Mutual interference prevention

When you install more than two products, there is a risk of mutual interference. Change the frequency to prevent this interference.

Change to frequency A or B using setting switch or atLightCurtain.

If you change the frequency, the response time may be changed and affect original response time.

4.5.1 Change settings

You can change settings via setting switch or atLightCurtain.

Only SFLA (advanced type) support atLightCurtain to change settings.

Setting item	Setting range	Factory default	Setting method	
			atLightCurtain	Setting switch (pin.no)
Frequency	Frequency A/B	Frequency A	○	○(3)

※When setting to frequency A, the frequency indicator turns off, and when setting to frequency B, it lights green. For more information, see "3.4.1 Status indicators".

5. Safety-related function

Light curtain supports safety-related functions to help installation or working environment.
When you configure the safety-related functions in atLightCurtain, see the table below.

○: available / ×: unavailable

	Interlock	Reset-hold	EDM	Muting	Override	Fixed Blanking	Floating Blanking	Reduce Resolution
Interlock	—	○ ^{※1}	○	○	○	○	○	○
Reset-hold	○ ^{※1}	—	○	× ^{※2}	× ^{※2}	× ^{※3}	× ^{※3}	○
EDM	○	○	—	○	○	○	○	○
Muting	○	× ^{※2}	○	—	○	○ ^{※4}	○ ^{※4}	×
Override	○	× ^{※2}	○	○	—	○	○	×
Fixed Blanking	○	× ^{※3}	○	○ ^{※4}	○	—	○ ^{※5}	×
Floating Blanking	○	× ^{※3}	○	○ ^{※4}	○	○ ^{※5}	—	×
Reduced Resolution	○	○	○	×	×	×	×	—

※1: The reset-hold function is available only when the manual reset is activated.

※2: The auxiliary output of emitter (AUX2) and reset-hold functions are not available when the muting or override is activated.

※3: The functional combination of the reset-hold with fixed blanking and floating blanking is unavailable.

※4: Both the muting zone and blanking zone can be set simultaneously.

※5: Both Functions, fixed blanking and floating blanking, are simultaneously configurable, but a zone where the two functions overlap cannot be set.

5.1 Interlock

Interlock is safety-related function, when OSSD output is switched to OFF state due to power on or, blocked beams or an error occurs during operation, keeping its OFF state when the beams are clear or the error is fixed.

The interlock is reset by auto-reset or manual reset.

5.1.1 Auto-reset

Auto-reset is a function that the OSSD is switched to ON state when all beams are clear without a reset input or power on again. The manual reset (start interlock and restart interlock) is deactivated.

Be sure to use the auto-reset in the environment where an operator cannot enter the detection zone or hazardous zone.

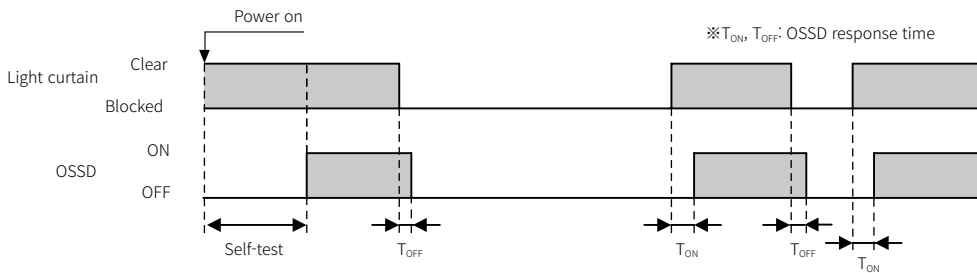

※Self-test completes within 2 seconds.

※For more information on response itme of OSSD output, see "2.2 Models"

5.1.2 Manual reset

One of start interlock or restart interlock is activated.

(When using the setting switch, the start interlock and restart interlock are activated or disactivated simultaneously.)

When using the manual reset, the interlock condition is released when reset input is applied after entering the interlock condition and all beams are clear. The OSSD output is switched from OFF state to ON state. The Interlock condition cannot be released when beams are blocked.

When using a combination of muting or override function, the interlock condition is reset when the override function is activated.

5.1.2.1 Start interlock

When the power is on, OSSD output remains OFF state regardless of the state of light curtain.

The interlock condition is released by applying the reset input. Apply reset input for more than 250ms.

(In this case, the reset-hold function is deactivated.)

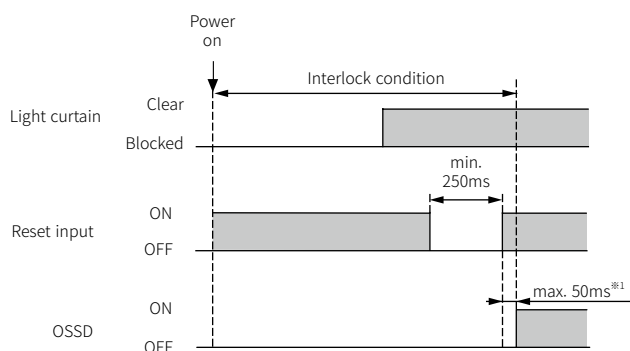

※1: It may differ depending on the series connection.



Entry condition of start interlock:

- When power is on
- Performs self-test after lockout reset
- Performs self-test after changing PC settings

5.1.2.2 Restart interlock

The OSSD output is switched to OFF and maintains when beams are blocked in normal operation environment. The interlock is reset by the reset input. Apply reset input for more than 250ms. (In this case, the reset-hold is deactivated.)

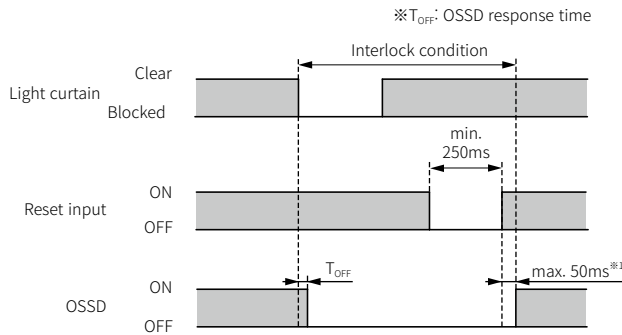

- ※1: It may differ depending on the series connection.
- ※For more information on response itme of OSSD output, see "2.2 Models".
- ※In case of series connection, if one of the product has a blocked beam, all the products are switched to the restart interlock condition.

5.1.2.3 Reset-hold

If the operator is hard to see and invisible to the hazardous zone, an interlock condition can be reset by an additional reset hold function with a reset input. Reset-hold can be set while manual reset is activated. When you use setting switch, activate manual reset and reset hold switch. Reset hold cannot be used in combination with muting, override, or blanking (fixed blanking and floating blanking) function. To reset the interlock, press the reset hold switch (S2) and then press the reset switch (S1) as shown below.

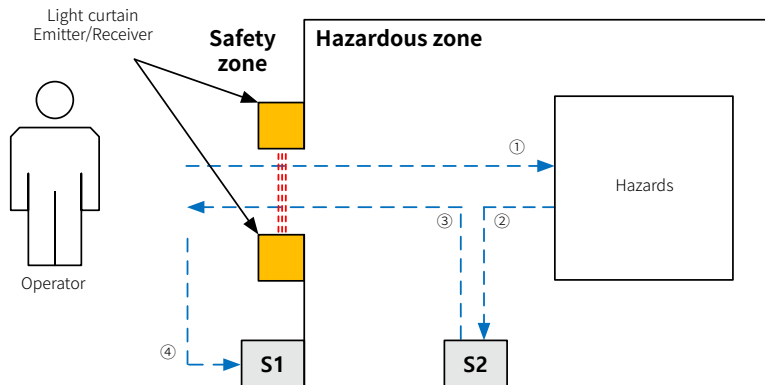

Procedure	Condition		Description
	Operating status	OSSD	
① Enter hazardous zone	Interlock	OFF	Enter the hazardous zone passing by the detection zone
② Reset hold	Interlock (Wait for reset hold)	OFF	Clear all works in the hazardous zone and then press the reset hold switch (S2).
③ Enter safety zone	Interlock (Wait for reset hold)	OFF	Go back to the safety zone passing by the detection zone within the maximum timeout
④ Reset input	Reset interlock	ON	Press the reset switch (S1) to reset the interlock



- If interlock is not released when reset input is applied, check the following cases and start the procedure again from the beginning.
- When the reset input is applied without applying the reset hold input
 - When the reset input is applied without passing by the detection zone after applying the reset hold input
 - When reset input or reset hold input is less than 250ms
 - When reset input or reset hold input is applied while the detection zone is interrupted
 - The reset hold wait time is released exceeding the reset-hold timeout after the reset hold input is applied

- Timing chart when setting reset hold

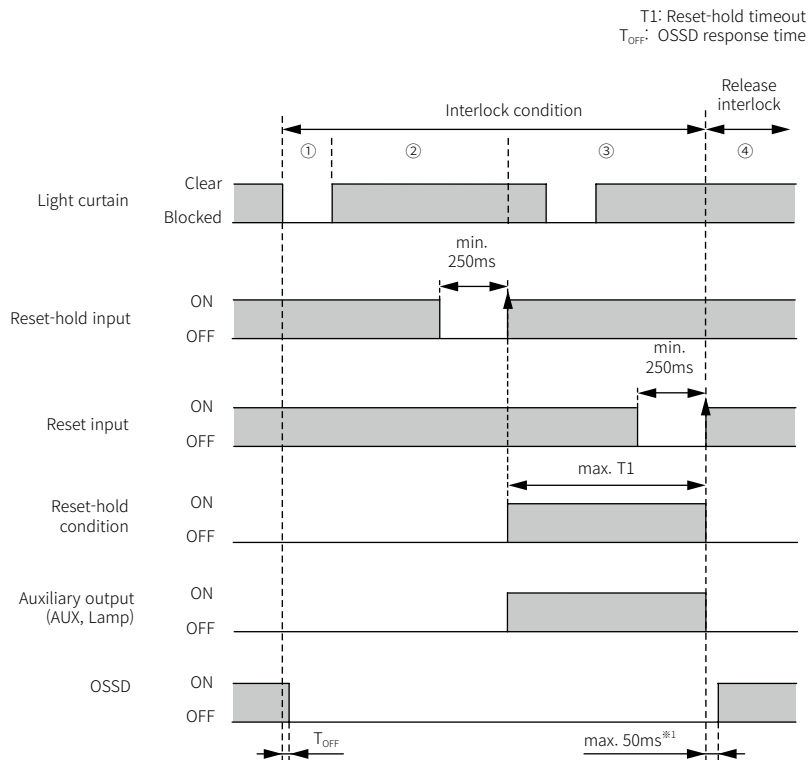

※1: It may differ depending on the series connection.

※If the reset hold input is applied, light curtain enters the reset hold condition, is maintained for the reset-hold timeout (T1).

※The interlock condition is released only when the reset input is applied after passing by the detection zone within the maximum timeout (T1).

In the series connection, the light curtains judge that an object passed by the detection zone if one light curtain is blocked. The interlock condition is not released unless the reset input is applied even if an object passing by the detection zone several times within the reset-hold timeout(T1). The reset-hold condition has been deactivated after the reset-hold timeout(T1).

※Please apply over 250ms for reset hold input or reset input.

※In case of advanced type, auxiliary output (AUX) and lamp output (Lamp) can be set to reset hold condition via atLightCurtain.

5.1.3 Wiring

(1) Start interlock / Restart interlock

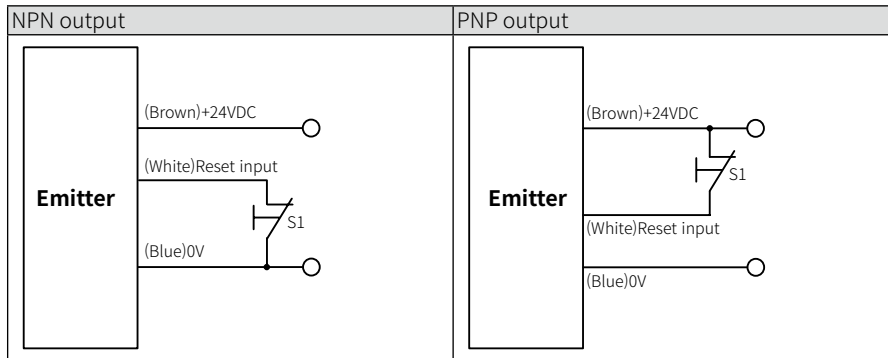

(2) Reset-hold

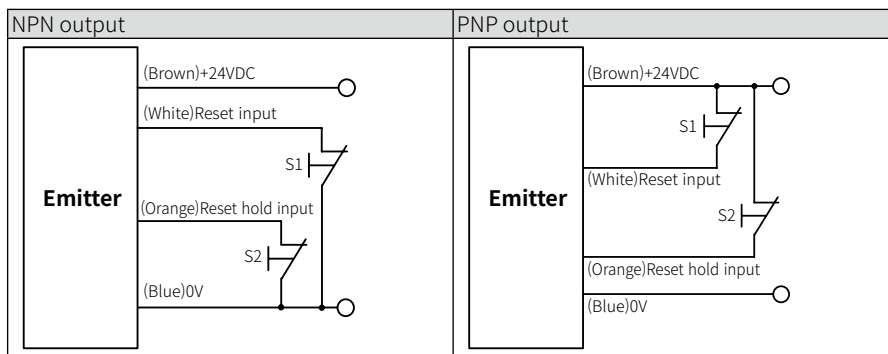

- ※Install reset switch (S1) and reset hold switch (S2) to release the interlock, and use normally closed (N.C.) contact switch.
- ※Install reset switch (S1) in a position where the entire hazardous zone is visible and cannot be used in the hazardous zone.
- ※Install reset hold switch (S2) in a position where cannot be used in the safety zone.
- ※When using the reset-hold, do not apply the external test input.

5.1.4 Change settings

You can change settings via setting switch or atLightCurtain. Only SFLA (advanced type) support atLightCurtain to change settings.

Function	Setting item	Setting range	Factory default	Setting method	
				atLightCurtain	Setting switch (pin no.)
Auto reset	Auto reset	Enable/Disable	Enable	○	○(5)
Manual reset	Start interlock	Enable/Disable	Disable		○(5)
	Restart interlock	Enable/Disable	Disable		○(5)
Reset-hold	Reset-hold	Enable/Disable	Disable		○(4)
	Timeout(T1)	1-60s	8s	—	

- ※When the function is activated by the setting switch, the setting range is the factory default.
- ※When setting manual reset by setting switch, the state of start interlock and restart interlock are the same.
- ※Combination of auto reset and reset hold is unavailable. When setting these at the same time, operating as auto reset.
- ※Combination of reset hold, muting, and override is unavailable. When setting these at the same time, entering the lockout condition.
- ※For more information on error and warnings, see "11. Troubleshooting".

5.2 Lockout reset

Lockout means that if an error occurs during self-test or operation, OSSD output goes to OFF state within the response time and maintains it.

After fixing the cause of the error, power on again or apply the reset input for more than 1 second. Then the light curtain performs self-test. If there is no error after the test, the lockout condition is released.

Depending on the cause of the error, the lockout condition may not be released.

If the lockout condition is not released by the reset input, power on again.

In case of series connection, if one of the product has a failure, all sets enter the lockout condition.

The lockout is reset from all sets when releasing lockout.

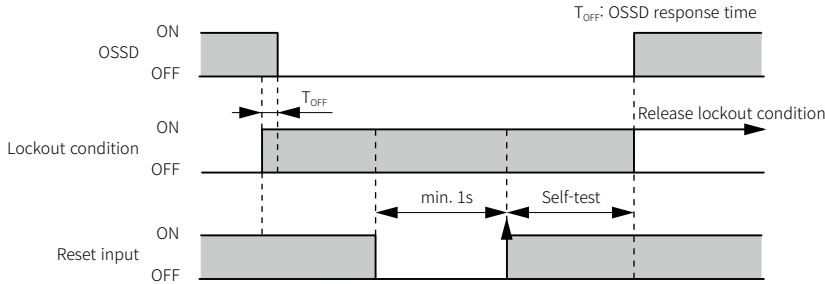

5.2.1 Wiring

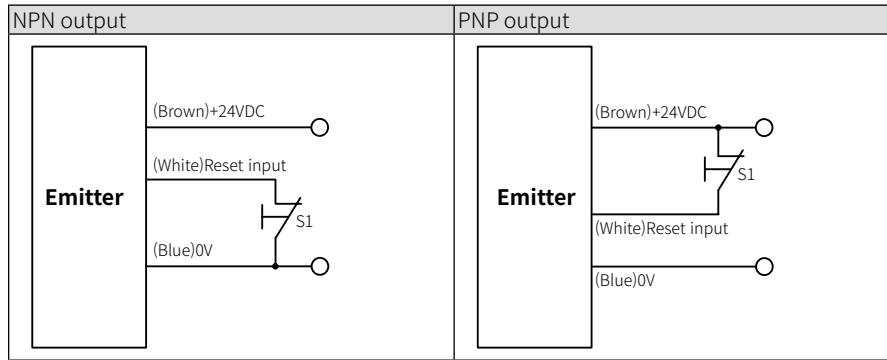

Note

- ※Install reset switch (S1) to release lockout and use normally closed (N.C.) contact switch.
- ※Install reset switch (S1) in a position where the entire hazardous zone is visible and cannot be used in the hazardous zone.
- ※The reset hold input is unavailable to reset the lockout.
- ※For more information on error and warnings, see "11. Troubleshooting".

5.3 External Device Monitoring (EDM)

This function monitors the state of external devices (e.g. safety relay, connectors, etc) connected to the OSSD output. It also diagnoses contact welding and malfunction of external devices to control a hazardous source.

The input of external device monitoring (EDM) must be applied as opposed to the state of OSSD output, and interprets abnormalities based on the input state when the OSSD output is switched.

If the rated voltage is not supplied to the EDM input within the timeout (T1) after the OSSD output is switched, entering lockout condition.

- Timing chart of EDM input

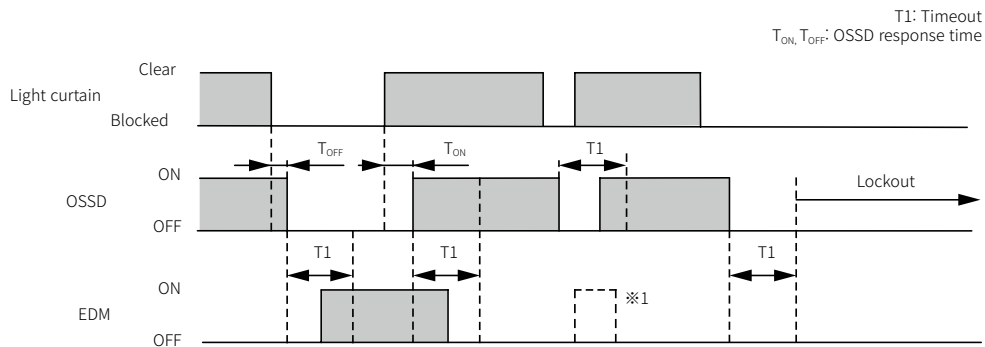

※1: If the OSSD is switched within the timeout (T1), light curtain operates normally though the signal is not applied to the EDM input.

5.3.1 Wiring

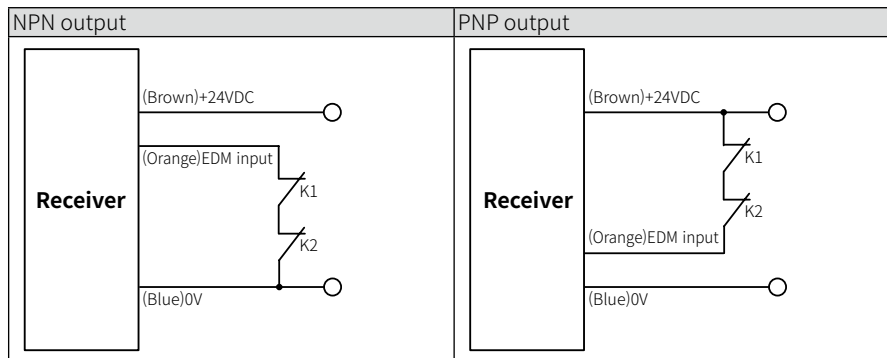

- ※Install external relay (K1, K2) for EDM input and use normally closed (N.C.) contacts switch for the rated voltage.
- ※Be sure to use a magnetic contactor or external relay with force-guided contacts as the K1 and K2 for proper usage.

5.3.2 Change settings

You can change settings via setting switch or atLightCurtain. Only SFLA (advanced type) support atLightCurtain to change settings.

Function	Setting item	Setting range	Factory default	Setting method	
				atLightCurtain	Setting switch (pin no.)
EDM	EDM function	Enable/Disable	Disable	○	○(6)
	Timeout(T1)	0.1 - 4sec	0.3sec		-

- ※When the function is activated by the setting switch, the setting range is the factory default.
- ※The EDM function should be activated by the setting switch or atLightCurtain to monitor the EDM indicator on the receiver. If not, the indicator doesn't show the status of EDM.
- ※For more information on error and warnings, see "11. Troubleshooting".

5.4 Muting

In the muting condition, the OSSD output maintains ON state regardless of the object in the muting zone.

The factory default of muting zone is set to entire detection zone.

The part of muting zone can be set via atLightCurtain.

Muting begins when the signals are correctly applied to the two mute inputs on the emitter, and ends by an end condition.

Muting suspends the safety-related functions temporarily so that it should be used in an environment where the detection objects, such as workpieces, frequently pass through the detection zone (e.g., conveyor systems).

When using a combination of muting and blanking functions, the muting and blanking zones can be overlapped.

- Fixed blanking: Fixed blanking is prioritized because it is unavailable to distinguish between the fixed object and the detection object
- Floating blanking: Muting is prioritized because it is unavailable to distinguish between the moving object and the detection object.

※If you need to show that the muting function is activated, install the indicator (e.g., warning lamp) where it can be checked at all sites.



Warning

Be sure to install the muting devices where the qualified personnel only can handle and change. Make sure that the installation position can be changed under the supervision of the responsible person for use.



Note

Muting sensor is a device to control the start and end of the muting function.

The muting sensors are connected to the mute1 input and mute 2 input, providing the outputs.

The specifications of the muting sensor as follows:

- i. Use sensors that have the same output type (NPN or PNP)
- ii. Use sensors that have 3-wire or N.O. contacts
In case of the SFLA (advanced type of light curtain), use atLightCurtain to select N.O. or N.C. contact based on the output type of muting sensor.
- iii. Use sensors that output is ON when detecting an object, and operate in Dark ON mode

When you use the photoelectric sensor as a muting sensor, light interference may occur and it may cause malfunction of the muting.

When an error occurs, see the following measures

- Use a sensor with mutual interference prevention
- Adjust the sensor position and beams to avoid interference
- Install a light shield plate, an anti-interference filter, or a slit
- Lower the sensitivity of the sensor

For more information on error and warnings, see "11. Troubleshooting".

For more information on the external indicators, see "6.6 Lamp output (Lamp 1/2)"

5.4.1 Standard mode

The standard mode is the factory default of muting. Muting starts by signals from the correct mute input sequence which you set. The initial setting of mute input sequence is 1 → 2 and it can be changed via atLightCurtain.

- Muting start condition (All conditions are required.)
 - i. Not lockout condition
 - ii. There is no object in the detection zone and the OSSD output is in ON state.
(If you use the muting function with the blanking function, keep the blanking zone blocked.)
 - iii. Mute 1 and mute 2 inputs are applied within the range of mute input time limit (T1min - T1max) based on the sequence you set.
 - iv. The monitoring result of lamp output is normal.
(The output mode of lamp output should be set to Muting/Override.)Muting end condition (One or more conditions are required.)

- v. Enter lockout condition
- vi. Mute 1 input or mute 2 input maintains OFF state for more than the allowable mute input time (max. 0.1 seconds).
- vii. The input signals from the muting sensors are unstable within the allowable mute input time.
- viii. The duration of muting period exceeds the muting timeout (T2).
- ix. The beams out of the muting zone are blocked.
(If you use the muting function with the blanking function, the muting ends if there is no object in the blanking zone.)
- x. The monitoring result of lamp output is abnormal.
(The output mode of lamp output should be set to Muting/Override.)

• Timing chart of standard mode

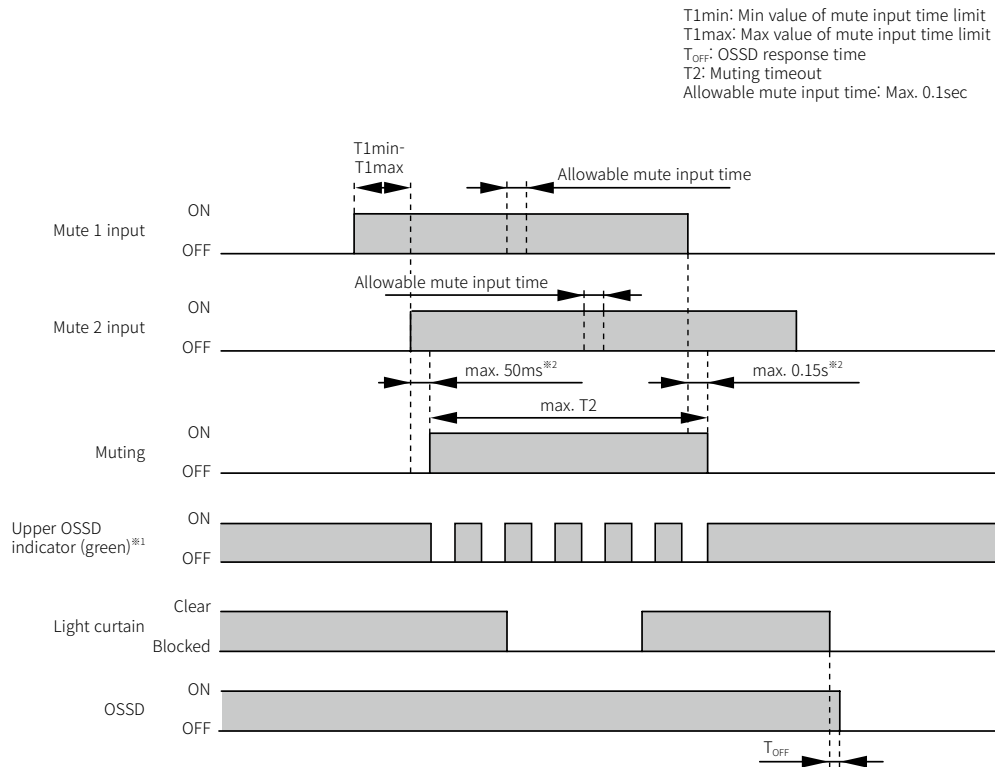

- ※1: The upper OSSD indicator flashes every 1 second.
- ※2: It may differ depending on the series connection.

Note

- ※Mute input time limit (T1min - T1max) is the time difference between mute 1 input, and mute 2 input. Muting starts by signals from the correct mute input sequence which you set. The signals should be applied within a range of the mute input time limit.(T1min < T1max)
- ※The muting timeout (T2) is the maximum value that the muting condition can be maintained.
- ※If the mute input is temporarily interrupted during the muting, it will operate normally when it returns within the allowable mute input time (0.1 sec.). If the mute input is not applied within the allowable mute input time or the mute input is unstable, the light curtain operates like below.
 - In muting condition: Muting ends and goes into warning condition. OSSD output is displayed based on the state of beams that are clear or blocked.
 - Not in muting condition: Muting does not begin even if the sequence of the mute inputs are correct. Muting sensor error is displayed on the segment LEDs.
- ※The auxiliary output (AUX 1/2) or lamp output (Lamp 1/2) can display the muting condition.
For more information, see "6.5 Auxiliary output (AUX 1/2)", "6.6 Lamp output (Lamp 1/2)"
- ※For more information on error and warnings, see "11. Troubleshooting".

5.4.1.1 When using two muting sensors in standard mode

(1) Wiring

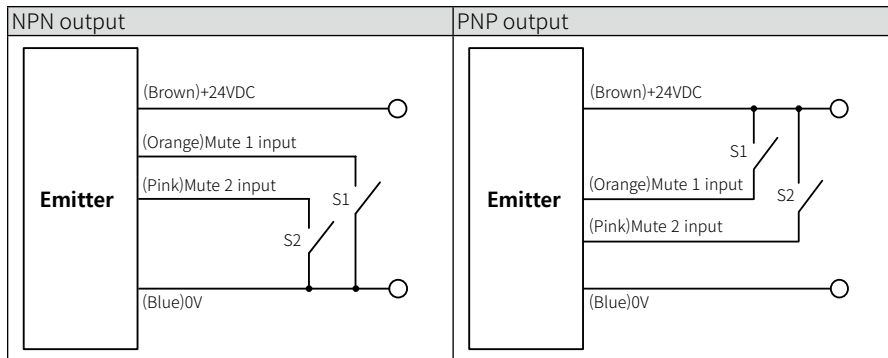

※Muting sensors (S1, S2) have the same output type (NPN, PNP) and 3-wire transistor output. Use sensors that output is ON when detecting an object, and operate in Dark ON mode.

※In case of SFL (standard type), use the muting sensors with N.O. contact. In case of SFLA (advanced type), use atLightCurtain to set N.O. or N.C. contact based on the output type of muting sensor.

(2) Example of muting function

While a workpiece is passing through the detection zone from the safety zone to the hazardous zone, muting begins by signals from two muting sensors installed across.

• Installation example

Muting sensors (S1, S2): Retro-reflective photoelectric sensor (Output is ON when sensing the object, Dark ON mode)

Muting sequence: Mute input 1 → 2

Item	Unit	Description
L	m	Length of detection object
V	m/s	Velocity of detection object
D	m	The distance at the muting sensors labeled S1/S2 firstly detect an object.
T1min	sec	Min value of mute Input time limit (T1)
T1max	sec	Max value of mute Input time limit (T1)

※To begin the muting and maintain it, make sure that the distance (D) must be smaller than the length (L) of the detection object. ($D < L$)

※Be sure to set the time between first mute input and the second mute input (D/V) within the mute input time limit. ($T1min < (D/V) < T1max$)

Order	Example of operation (●: ON, ●: OFF)				
①					
	<p>The muting sensors (S1, S2) are in OFF state before the workpiece passes. Muting is deactivated but the sensing function is activated.</p> <p>※1: Install the muting sensors whose intersection should be located in a hazardous zone to prevent starting the muting by an operator.</p>				
	<table border="0"> <tr> <td>Mute 1 input ●</td> <td>S1 ●</td> </tr> <tr> <td>Mute 2 input ●</td> <td>S2 ●</td> </tr> </table>	Mute 1 input ●	S1 ●	Mute 2 input ●	S2 ●
Mute 1 input ●	S1 ●				
Mute 2 input ●	S2 ●				

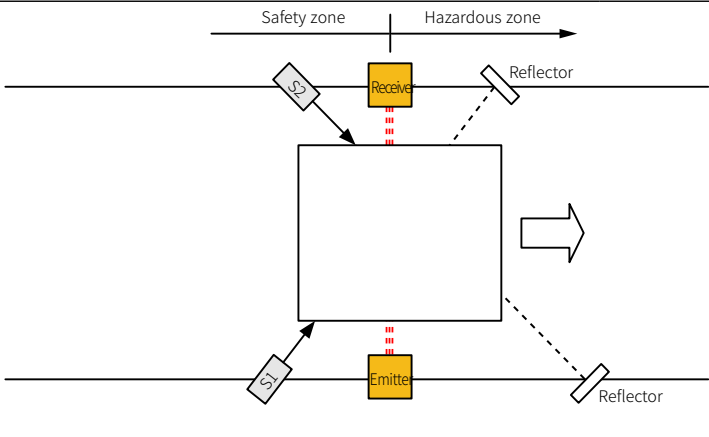
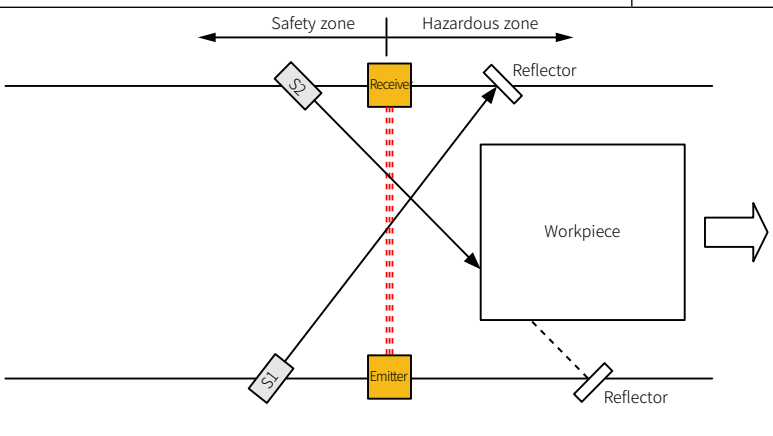
Order	Example of operation (●: ON, ●: OFF)		
②			
	<p>The muting sensors (S1, S2) detect the workpiece and outputs go to ON state in order and muting begins. The sensing function is deactivated. Even if the beams of muting zone are blocked, the OSSD output maintains ON.</p>	<p>Mute 1 input ●</p>	<p>S1 ●</p>
		<p>Mute 2 input ●</p>	<p>S2 ●</p>
③			
	<p>The output of muting sensor (S2) maintains ON state but the muting sensor (S1) is in OFF state. The muting ends and the sensing function is activated.</p>	<p>Mute 1 input ●</p>	<p>S1 ●</p>
		<p>Mute 2 input ●</p>	<p>S2 ●</p>

(3) Timing chart

T1min: Min value of mute input time limit
 T1max: Max value of mute input time limit
 T2: Muting timeout

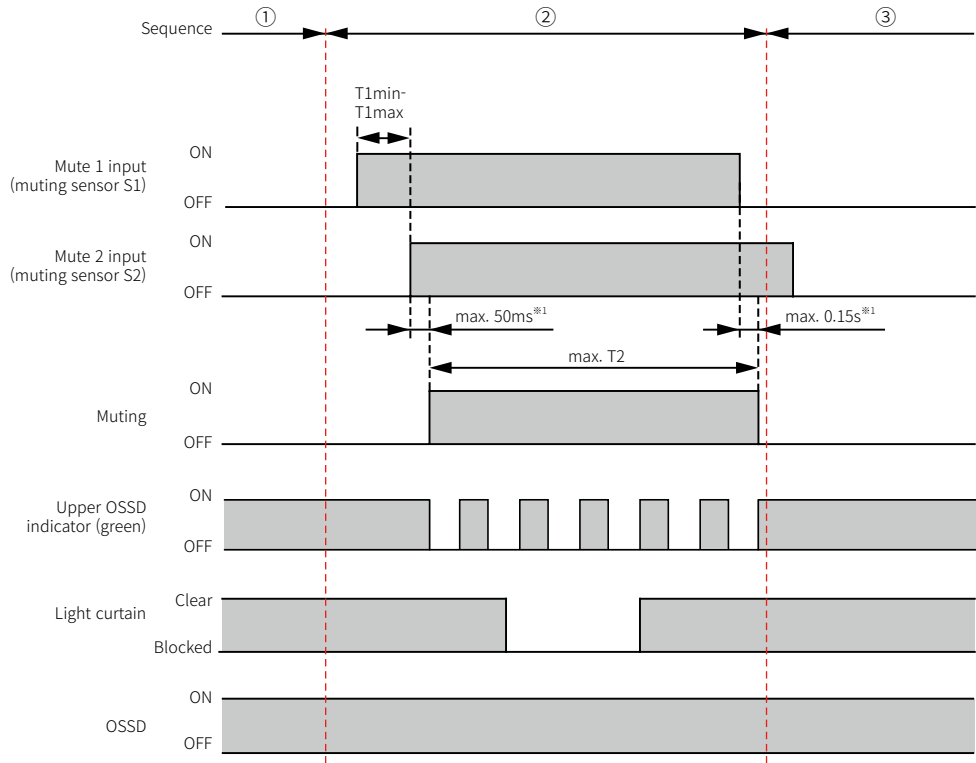

※1: It may differ depending on the series connection.

5.4.1.2 When using four muting sensors in standard mode (one direction of the detection object)

(1) Wiring

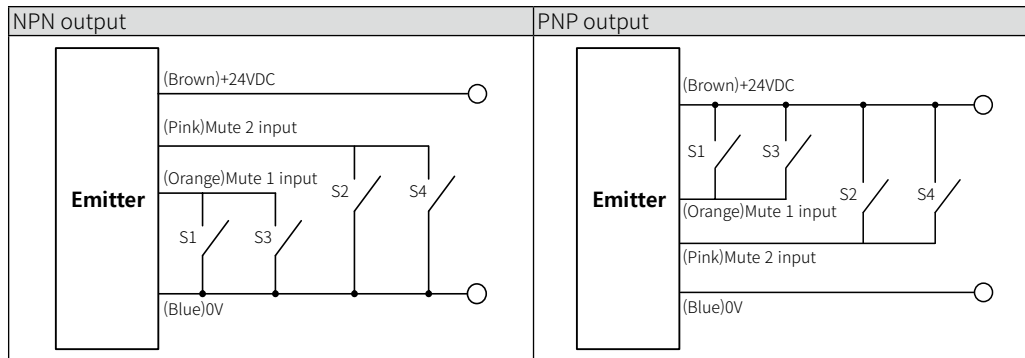

- ※Muting sensors (S1, S2, S3, S4) have the same output type (NPN, PNP) and 3-wire transistor output. Use sensors that output is ON when detecting an object, and operate in Dark ON mode.
- ※In case of SFL (standard type), use the muting sensors with N.O. contact.
In case of SFLA (advanced type), use atLightCurtain to set N.O. or N.C. contact based on the output type of muting sensor.

(2) Example of muting function

While a workpiece is passing through the detection zone from the safety zone to the hazardous zone, one-direction muting begins by signals from four muting sensors installed in parallel.

• Installation example

Muting sensors (S1, S2, S3, S4): Through-beam photoelectric sensor
(Output is ON when sensing the object, Dark ON mode)

Muting sequence: Mute input 1 → 2

- ※Connect the outputs of muting sensors (S1, S3) to mute 1 input.
- ※Connect the outputs of muting sensors (S2, S4) to mute 2 input.

Item	Unit	Description
L	m	Length of the object
V	m/s	Velocity of the object
D1	m	The distance at the muting sensors labeled S1/S2 firstly detect an object. (When the detection object moves to the right.)
D2	m	Distance between the muting sensors labeled S2/S4
D3	m	Distance between the muting sensors labeled S1/S3
T1min	sec	Min value of mute Input time limit (T1)
T1max	sec	Max value of mute Input time limit (T1)

- ※Be sure to install the muting sensors for the values of D2 and D3 shorter than the L. ($D2 < L, D3 < L$)
- ※Muting begins when mute 2 input is applied after mute 1 input is applied within the mute input time limit (T1). ($T1min < (D/V) < T1max$)

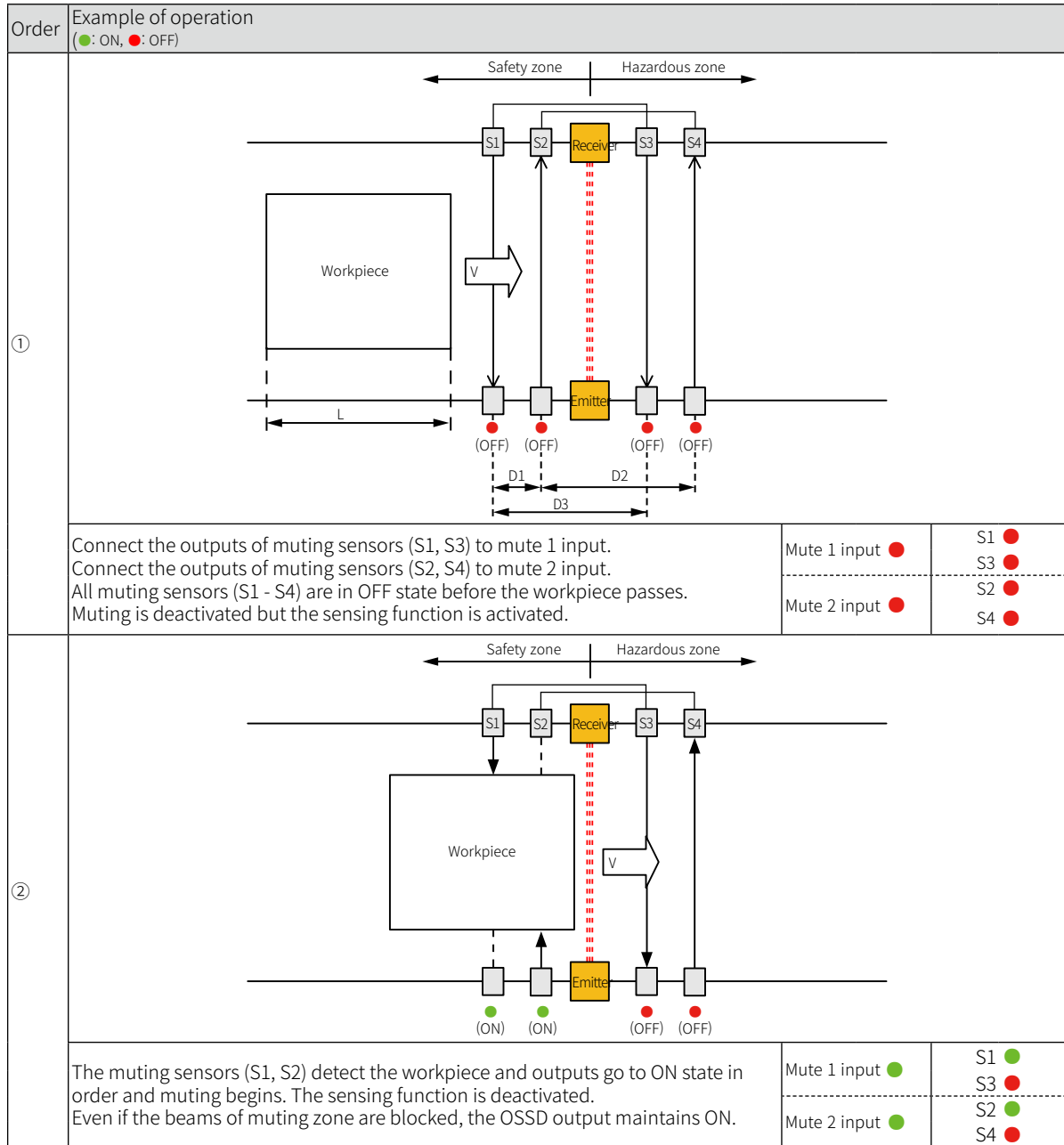

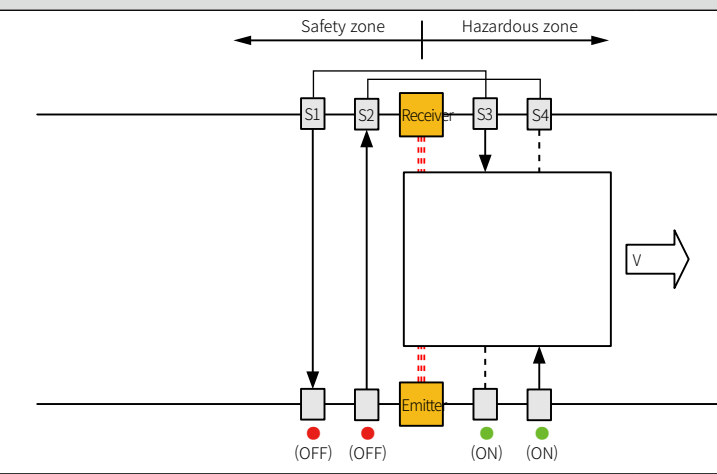
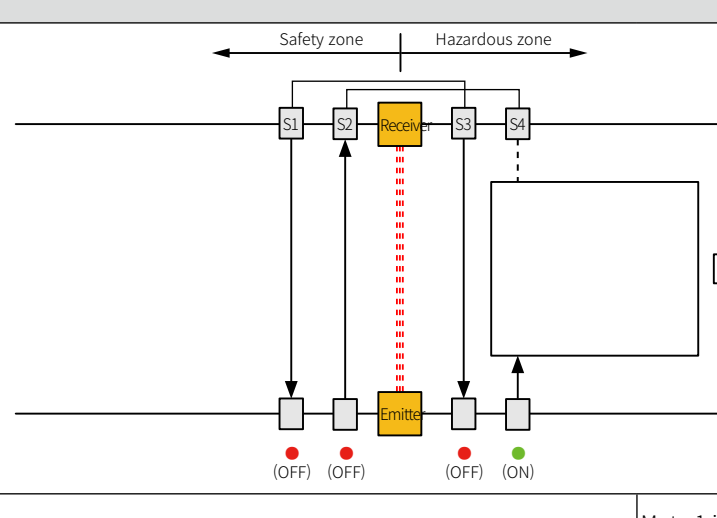
<p>Order</p> <p>③</p>	<p>Example of operation (●: ON, ●: OFF)</p>  <p>The muting sensors (S3, S4) maintains ON state even if the muting sensors (S1, S2) are in OFF state, the OSSD output is in ON state. The sensing function is deactivated.</p>	<p>Mute 1 input ●</p> <p>Mute 2 input ●</p>	<p>S1 ●</p> <p>S3 ●</p> <p>S2 ●</p> <p>S4 ●</p>
<p>Order</p> <p>④</p>	<p>Example of operation (●: ON, ●: OFF)</p>  <p>The output of muting sensor (S3) is switched to OFF state and the mute 1 input is in OFF state. The muting ends and the sensing function is activated.</p>	<p>Mute 1 input ●</p> <p>Mute 2 input ●</p>	<p>S1 ●</p> <p>S3 ●</p> <p>S2 ●</p> <p>S4 ●</p>

(3) Timing chart

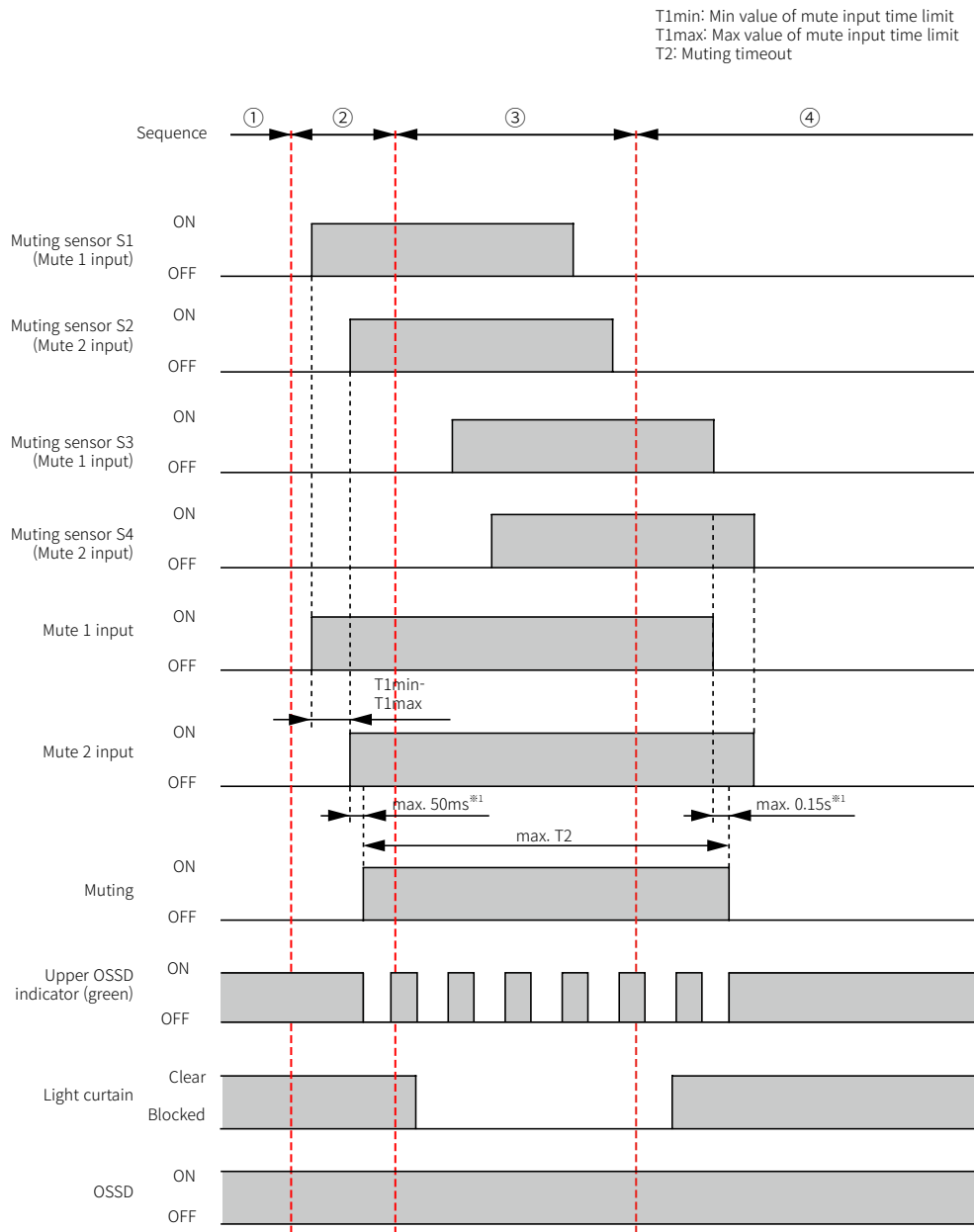

※1: It may differ depending on the series connection.

5.4.1.3 When using four muting sensors in standard mode (both directions of the detection object)

(1) Wiring

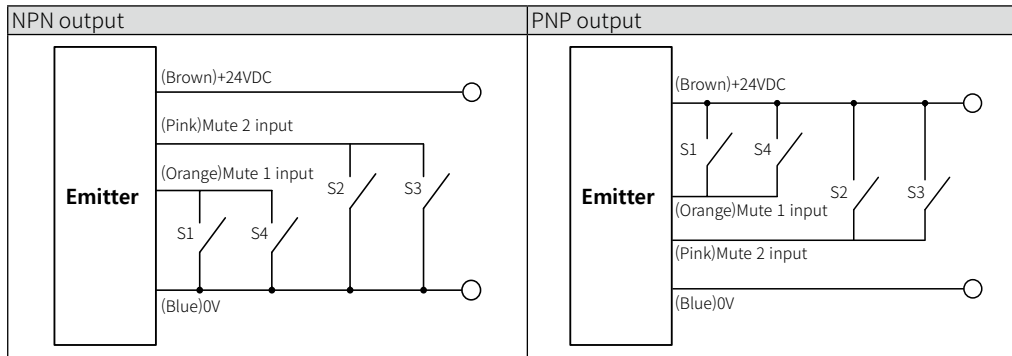

※Muting sensors (S1, S2, S3, S4) have the same output type (NPN, PNP) and 3-wire transistor output. Use sensors that output is ON when detecting an object, and operate in Dark ON mode.

※In case of SFL (standard type), use the muting sensors with N.O. contact. In case of SFLA (advanced type), use atLightCurtain to set N.O. or N.C. contact based on the output type of muting sensor.

(2) Example of muting function

While a workpiece is passing through the detection zone from the safety zone to the hazardous zone, both-direction muting begins by signals from four muting sensors installed in parallel.

• Installation example

Muting sensors (S1, S2, S3, S4): Through-beam photoelectric sensor
(Output is ON when sensing the object, Dark ON mode)

Muting sequence: Mute input 1 → 2

※Connect the outputs of muting sensors (S1, S4) to mute 1 input.

※Connect the outputs of muting sensors (S2, S3) to mute 2 input.

Item	Unit	Description
L	m	Length of the object
V	m/s	Velocity of the object
D1	m	The distance at the muting sensors labeled S1/S2 firstly detect an object. (When the detection object moves to the right.)
D2	m	The distance at the muting sensors labeled S3/S4 firstly detect an object. (When the detection object moves to the left.)
D3	m	Distance between the muting sensors labeled S1/S4.
T1min	sec	Min value of mute Input time limit (T1)
T1max	sec	Max value of mute Input time limit (T1)

※Be sure to install the muting sensors for the value of D3 shorter than the L. (D3 < L)

※Muting begins when mute 2 input is applied after mute 1 input is applied within the mute input time limit (T1).
($T1min < (D1/V) < T1max$ or $T1min < (D2/V) < T1max$)

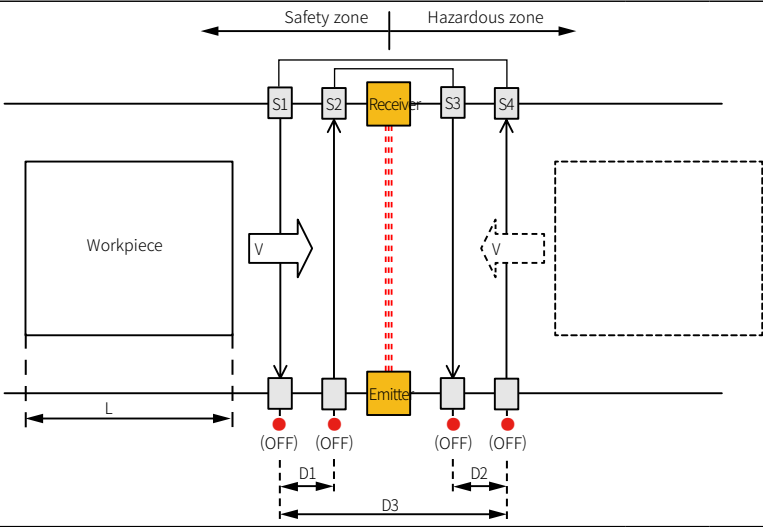
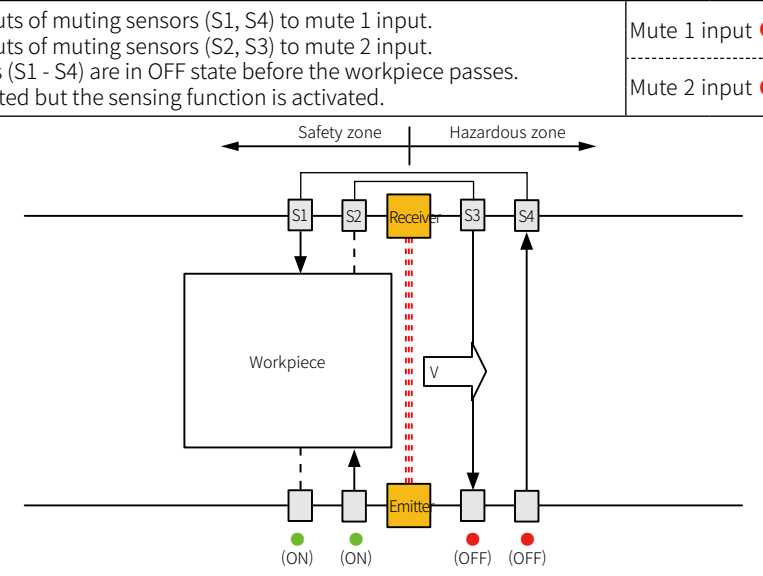
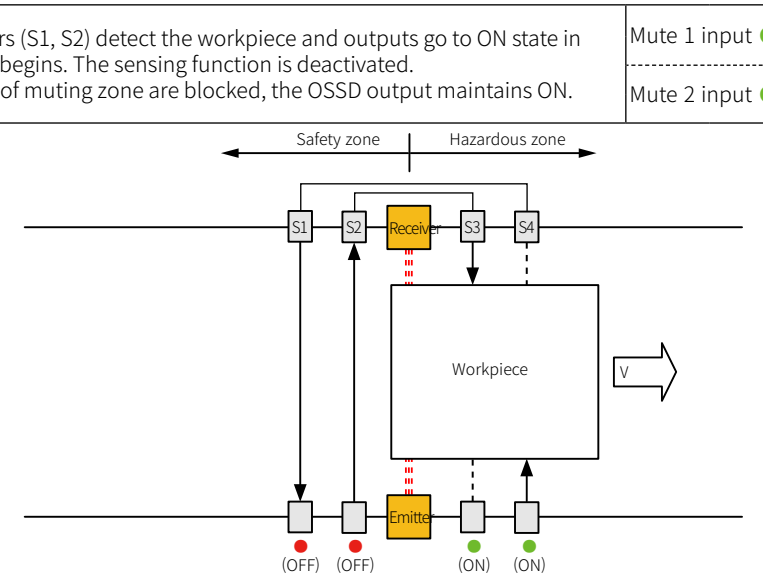
Order	Example of operation (●: ON, ●: OFF)									
①	 <p>Diagram 1 shows a safety zone on the left and a hazardous zone on the right. A workpiece is moving from left to right, indicated by a solid arrow 'V'. The workpiece length is 'L'. There are four muting sensors: S1 and S2 in the safety zone, and S3 and S4 in the hazardous zone. An emitter and receiver are positioned between S2 and S3. All sensors are currently OFF (indicated by red dots). Distances D1, D2, and D3 are marked between the sensors.</p>	<p>Connect the outputs of muting sensors (S1, S4) to mute 1 input. Connect the outputs of muting sensors (S2, S3) to mute 2 input. All muting sensors (S1 - S4) are in OFF state before the workpiece passes. Muting is deactivated but the sensing function is activated.</p> <table border="1" data-bbox="1118 801 1433 913"> <tr> <td>Mute 1 input ●</td> <td>S1 ●</td> </tr> <tr> <td></td> <td>S4 ●</td> </tr> <tr> <td>Mute 2 input ●</td> <td>S2 ●</td> </tr> <tr> <td></td> <td>S3 ●</td> </tr> </table>	Mute 1 input ●	S1 ●		S4 ●	Mute 2 input ●	S2 ●		S3 ●
Mute 1 input ●	S1 ●									
	S4 ●									
Mute 2 input ●	S2 ●									
	S3 ●									
②	 <p>Diagram 2 shows the workpiece has moved further into the hazardous zone, indicated by a dashed arrow 'V'. Sensors S1 and S2 are now ON (green dots), while S3 and S4 remain OFF (red dots). The OSSD output maintains ON.</p>	<p>The muting sensors (S1, S2) detect the workpiece and outputs go to ON state in order and muting begins. The sensing function is deactivated. Even if the beams of muting zone are blocked, the OSSD output maintains ON.</p> <table border="1" data-bbox="1118 1375 1433 1487"> <tr> <td>Mute 1 input ●</td> <td>S1 ●</td> </tr> <tr> <td></td> <td>S4 ●</td> </tr> <tr> <td>Mute 2 input ●</td> <td>S2 ●</td> </tr> <tr> <td></td> <td>S3 ●</td> </tr> </table>	Mute 1 input ●	S1 ●		S4 ●	Mute 2 input ●	S2 ●		S3 ●
Mute 1 input ●	S1 ●									
	S4 ●									
Mute 2 input ●	S2 ●									
	S3 ●									
③	 <p>Diagram 3 shows the workpiece is now in the hazardous zone, indicated by a solid arrow 'V'. Sensors S3 and S4 are now ON (green dots), while S1 and S2 are OFF (red dots). The OSSD output maintains ON.</p>	<p>The muting sensors (S3, S4) are switched to ON state even if the muting sensors (S1, S2) are in OFF state, the OSSD output maintains ON state. The sensing function is deactivated.</p> <table border="1" data-bbox="1118 1948 1433 2069"> <tr> <td>Mute 1 input ●</td> <td>S1 ●</td> </tr> <tr> <td></td> <td>S4 ●</td> </tr> <tr> <td>Mute 2 input ●</td> <td>S2 ●</td> </tr> <tr> <td></td> <td>S3 ●</td> </tr> </table>	Mute 1 input ●	S1 ●		S4 ●	Mute 2 input ●	S2 ●		S3 ●
Mute 1 input ●	S1 ●									
	S4 ●									
Mute 2 input ●	S2 ●									
	S3 ●									

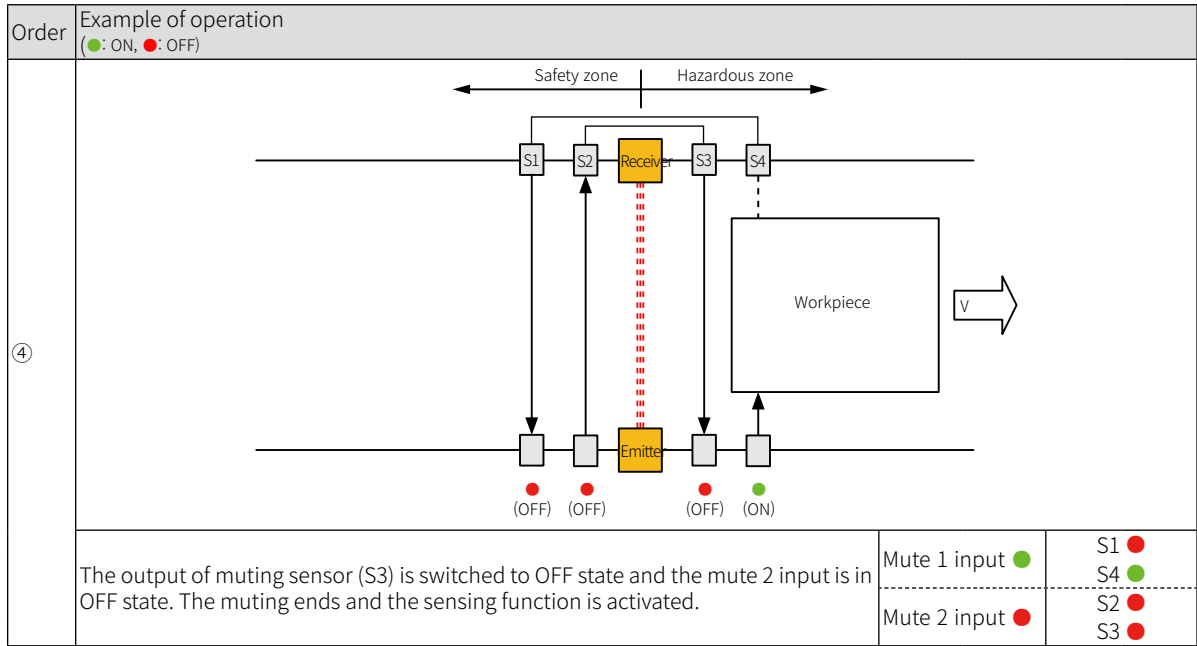

(3) Timing chart

T1min: Min value of mute input time limit
 T1max: Max value of mute input time limit
 T2: Muting timeout

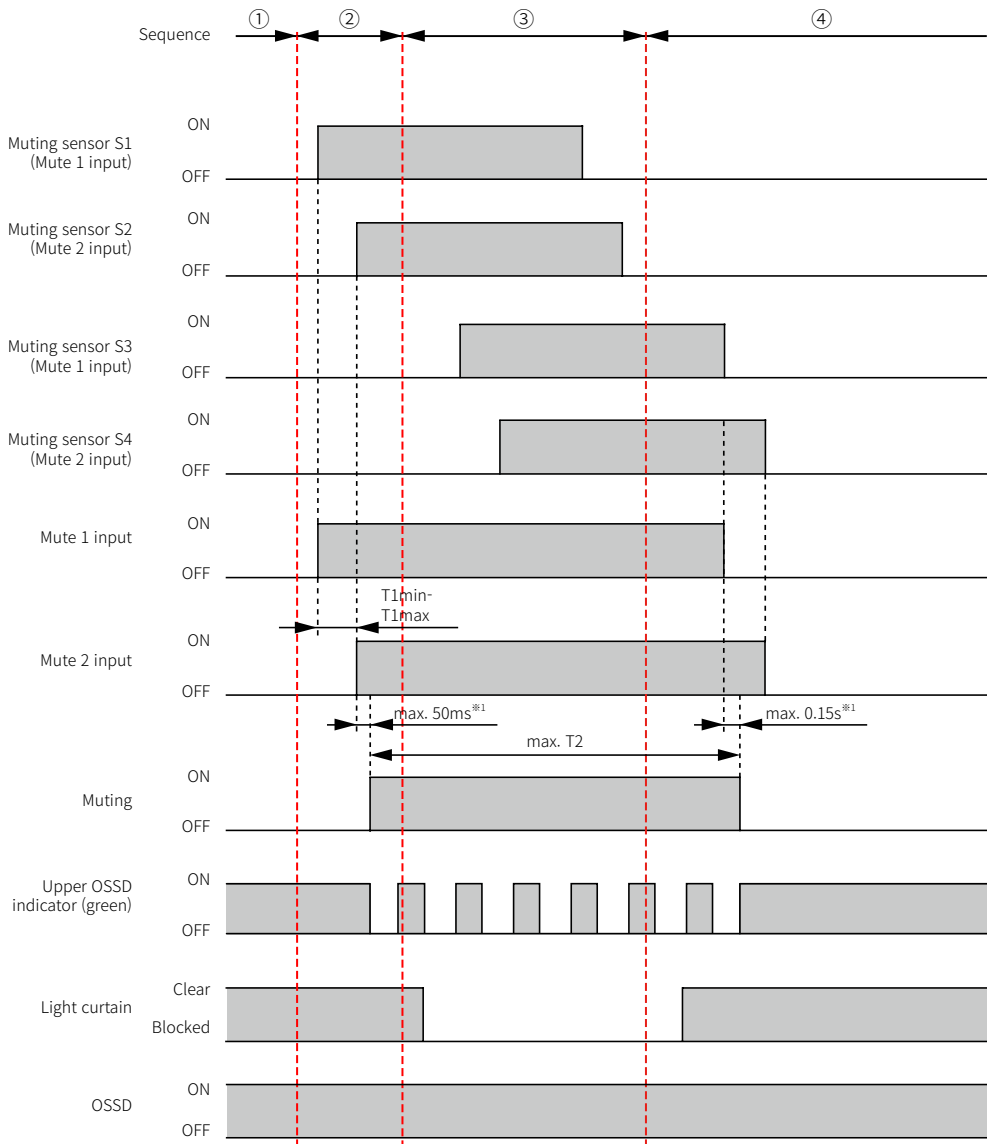

※1: It may differ depending on the series connection.

5.4.2 Exit-only mode

Muting starts by signals from the correct mute input sequence which you set. Muting condition is maintained during a certain time even if mute input is turned to OFF state.

The initial setting of mute input sequence is 1 → 2 and it can be changed via atLightCurtain. However, the both directions (1↔2) is unavailable.

- Muting start condition (All conditions are required.)
 - xi. Not lockout condition
 - xii. There is no object in the detection zone and the OSSD output is in ON state.
(If you use the muting function with the blanking function, keep the blanking zone blocked.)
 - xiii. Mute 1 and mute 2 inputs are applied within the range of mute input time limit (T1min - T1max) based on the sequence you set.
 - xiv. The monitoring result of lamp output is normal.
(The output mode of lamp output should be set to Muting/Override.)

- Muting end condition (One or more conditions are required.)
 - i. Enter lockout condition
 - ii. The muting zone is not blocked within the maximum mute input time limit (T1max) after the muting is activated.
 - iii. Mute 1 input or mute 2 input maintains OFF state for more than the allowable mute input time (max. 0.1 seconds) and remains the blocked state during the exit-only muting wait time (T3).
 - iv. The mute input is unstable within the allowable mute input time.
 - v. The beams except the muting zone are blocked.
(If you use the muting function with the blanking function, the muting ends if there is no object in the blanking zone.)
 - vi. The muting end wait time (0.1sec) is exceeded after the object passes through the detection zone.
 - vii. The muting timeout (T2) is exceeded.
 - viii. The monitoring result of lamp output is abnormal.
(The output mode of lamp output should be set to Muting/Override.)

T1min: Min value of mute input time limit
 T1max: Max value of mute input time limit
 T2: Muting timeout
 T3: Exit-only muting wait time
 Allowable mute input time: max. 0.1sec
 Muting end wait time: 0.1sec

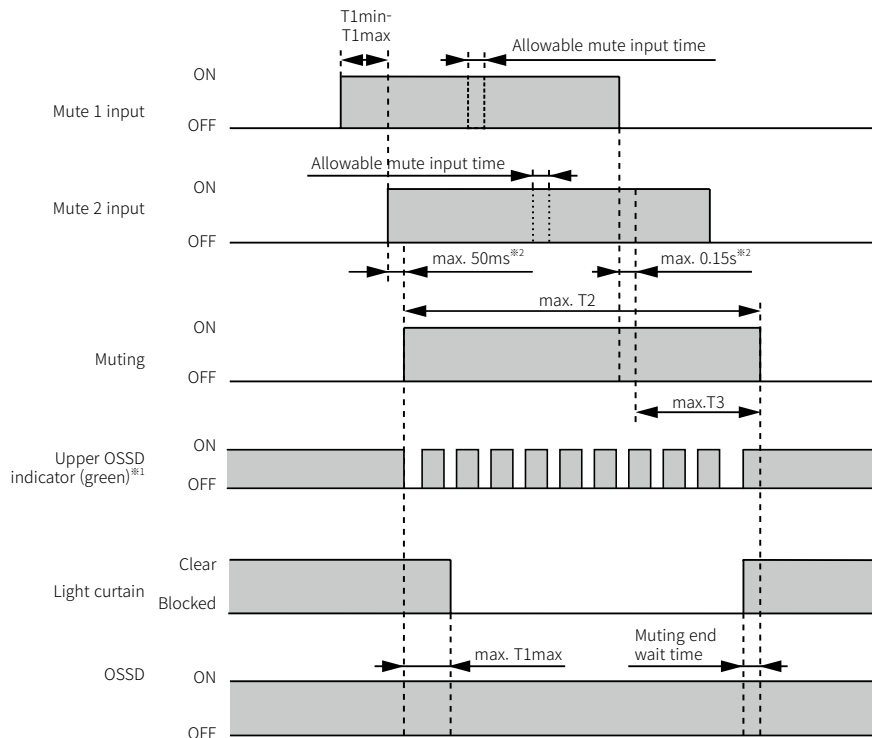

※1: The upper OSSD indicator flashes every 1 second.

※2: It may differ depending on the series connection.



※Mute input time limit ($T1min - T1max$) is the time difference between mute 1 input, and mute 2 input. Muting starts by signals from the correct mute input sequence which you set. The signals should be applied within a range of the mute input time limit. ($T1min < T1max$)

※The muting timeout ($T2$) is the maximum value that the muting condition can be maintained.

※Exit-only muting wait time ($T3$) is the time until the muting function ends after the mute input is switched to the OFF state.

※If the mute input is temporarily interrupted during the muting, it will operate normally when it returns within the allowable mute input time (0.1 sec). If the mute input is not applied within the allowable mute input time or the mute input is unstable, the light curtain operates like below.

- In muting condition: Muting ends and goes into warning condition.

OSSD output is displayed based on the state of beams that are clear or blocked.

- Not in muting condition: Muting does not begin even if the sequence of the mute inputs are correct.

Muting sensor error is displayed on the segment LEDs.

※The auxiliary output (AUX 1/2) or lamp output (Lamp 1/2) can display the muting condition.

For more information, see "6.5 Auxiliary output (AUX 1/2)", "6.6 Lamp output (Lamp 1/2)"

※For more information on error and warnings, see "11. Troubleshooting"

5.4.2.1 When using two muting sensors in exit-only mode

(1) Wiring

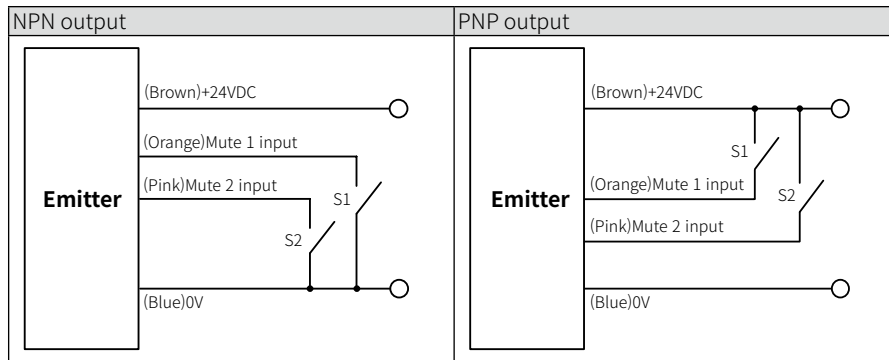

※Muting sensors (S1, S2) have the same output type (NPN, PNP) and 3-wire transistor output. Use sensors that output is ON when detecting an object, and operate in Dark ON mode.

※In case of SFL (standard type), use the muting sensors with N.O. contact. In case of SFLA (advanced type), use atLightCurtain to set N.O. or N.C. contact based on the output type of muting sensor.

(2) Example of exit-only muting function

While a workpiece is passing through the detection zone from the safety zone to the hazardous zone, muting begins by signals from two muting sensors installed parallel.

- Installation example

Muting sensors (S1, S2): Through-beam photoelectric sensor (Output is ON when sensing the object, Dark ON mode)

Muting sequence: Mute input 1 → 2

Item	Unit	Description
L	m	Length of the object
V	m/s	Velocity of the object
D1	m	Distance between the muting sensors labeled S1/S2
D2	m	Distance between the muting sensor labeled S1 and product
T1min	sec	Min value of mute Input time limit (T1)
T1max	sec	Max value of mute Input time limit (T1)

※If mute 2 input is applied within mute input time limit (T1) after mute 1 input is applied, the muting starts. ($T1min < (D1 / V) < T1max$)

※Be sure to maintain the muting condition after the detection object passes through the muting sensor and the detection zone. The following formula must be satisfied. ($(D2/V) < T3$)

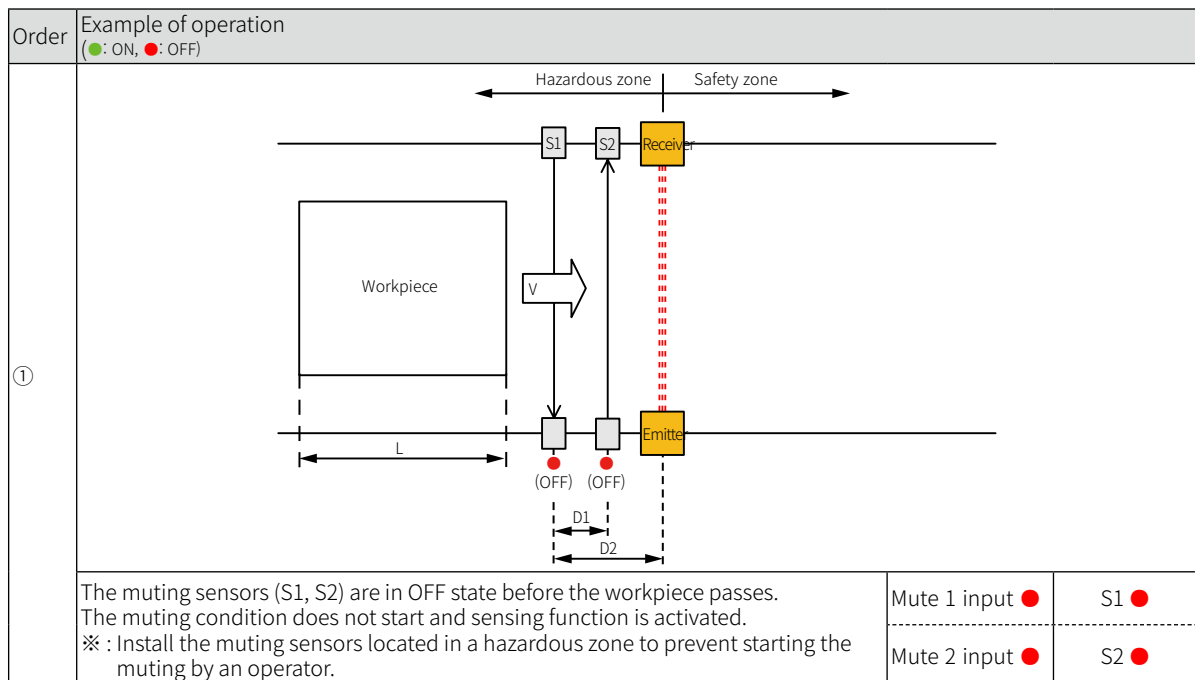

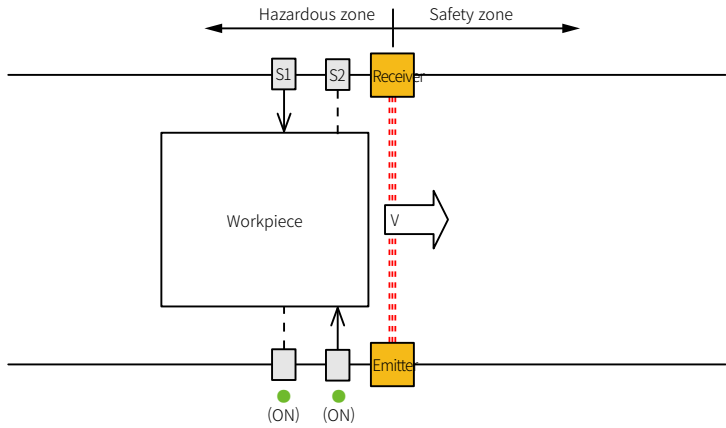
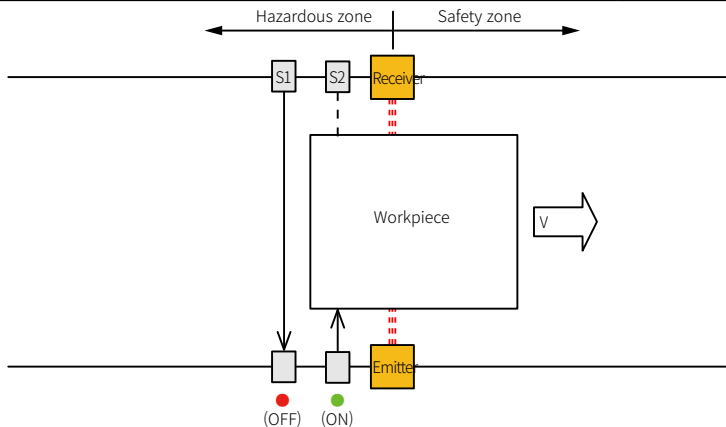
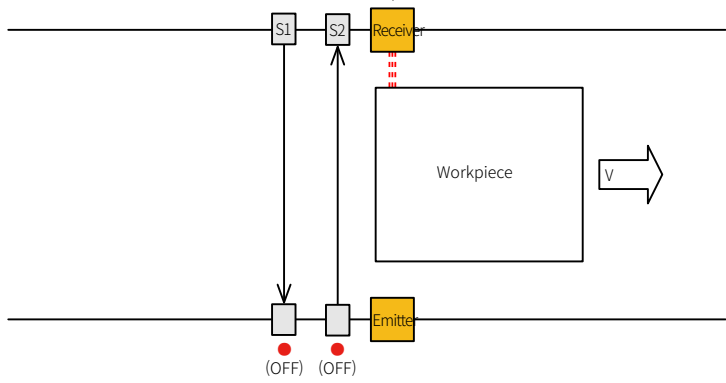
<p>Order</p> <p>②</p>	<p>Example of operation (●: ON, ●: OFF)</p>  <p>The muting sensors (S1, S2) detect the workpiece and the outputs go to ON state in order. Muting begins and the sensing function is deactivated. Even if the beams of the muting zone are blocked, the OSSD output maintains ON.</p>	<p>Mute 1 input ● S1 ●</p> <hr/> <p>Mute 2 input ● S2 ●</p>
<p>Order</p> <p>③</p>	<p>Example of operation (●: ON, ●: OFF)</p>  <p>Even if the output of the muting sensor(S2) maintains ON state, the muting sensor(S1) is switched to OFF state. The muting condition is maintained for the exit-only muting wait time (T3). The sensing function is deactivated.</p>	<p>Mute 1 input ● S1 ●</p> <hr/> <p>Mute 2 input ● S2 ●</p>
<p>Order</p> <p>④</p>	<p>Example of operation (●: ON, ●: OFF)</p>  <p>Even if both muting sensors (S1, S2) are switched to OFF state within exit-only muting wait time (T3), the muting condition is maintained. The sensing function is deactivated.</p>	<p>Mute 1 input ● S1 ●</p> <hr/> <p>Mute 2 input ● S2 ●</p>

Order	Example of operation (●: ON, ●: OFF)					
⑤						
If the workpiece passes through the detection zone completely and the beams are clear, the muting condition is maintained for 0.1 sec (Muting end wait time) and stops. The sensing function is activated.		<table border="1"> <tr> <td>Mute 1 input ●</td> <td>S1 ●</td> </tr> <tr> <td>Mute 2 input ●</td> <td>S2 ●</td> </tr> </table>	Mute 1 input ●	S1 ●	Mute 2 input ●	S2 ●
Mute 1 input ●	S1 ●					
Mute 2 input ●	S2 ●					

(3) Timing chart

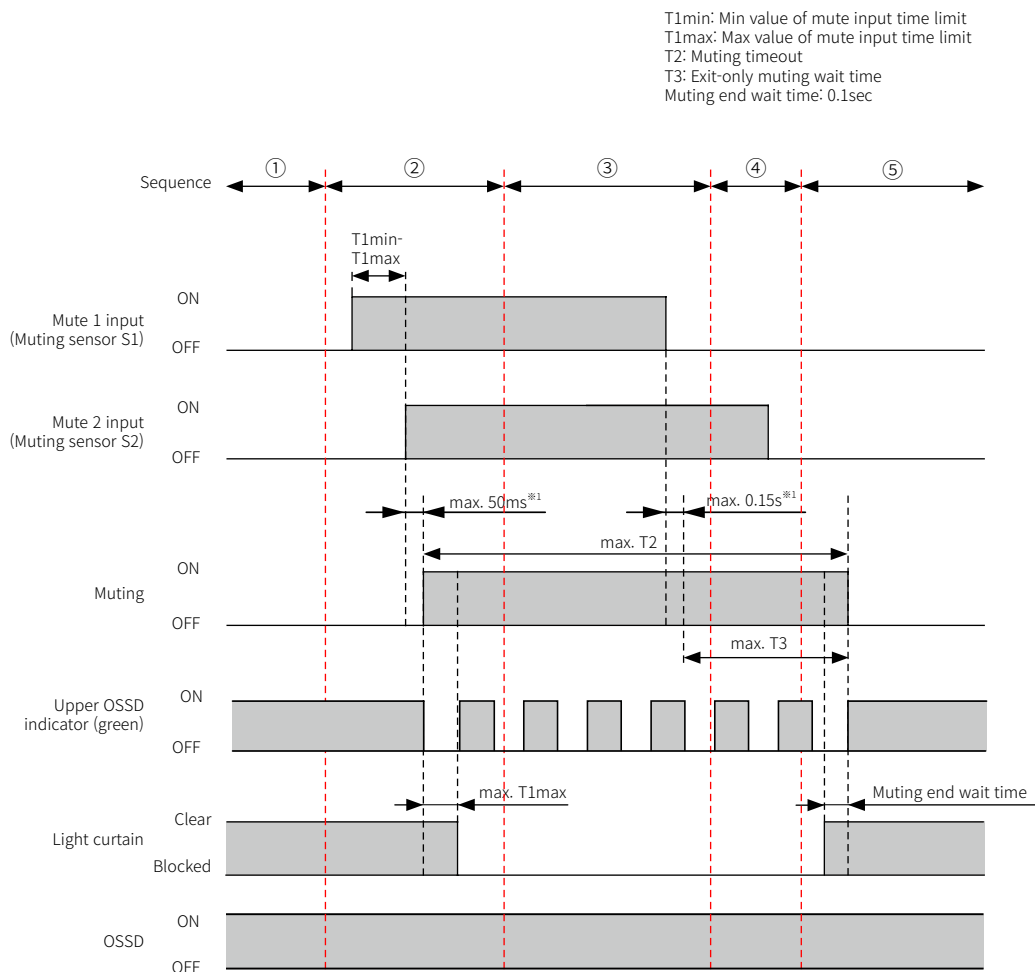

※1: It may differ depending on the series connection.

5.4.3 Change settings

You can change settings via setting switch or atLightCurtain.
Only SFLA (advanced type) support atLightCurtain to change settings.

Function	Item	Setting range	Factory default	Setting method	
				atLightCurtain	Setting switch (pin no.)
Muting	Muting function	Enable/Disable	Disable	○	○(7)
	Muting zone ^{*1}	Detection zone	Entire zone		—
	Muting mode	Standard mode/ Exit-only mode	Standard mode		
	Muting sequence ^{*2}	One direction: 1→2/2→1 Both direction: 1↔2	1→2		
	Muting sensor 1	N.O./N.C.	N.O.		
	Muting sensor 2	N.O./N.C.	N.O.		
	Min value of mute input time limit (T1min)	0.03-3.9sec	0.03sec		
	Max value of mute input time limit (T1max)	0.1-10sec	3sec		
	Muting timeout (T2) ^{*3}	0-3600sec	60sec		
Exit-only muting wait time(T3)	0.1-4sec	4sec			

※When the function is activated by the setting switch, the setting range is the factory default.

※1: Even if the beams set to the muting zone are blocked, the OSSD output remains ON state. When using a combination of muting and blanking functions, the muting zone and the blanking zone can be overlapped.
The muting zone can be set manually or automatically in atLightCurtain.
For more information, see “*atLightCurtain User Manual*.”

※2: When muting mode is set to exit-only mode, the muting sequence cannot be set in both directions.

※3: If you set the Muting timeout (T2) to 0, it is set to 'unlimited' and it may cause continuous muting condition unintentionally. In this case, the operator should perform a sufficient risk assessment and take additional safety measures.

5.5 Override

Muting function ends due to the muting conditions, and OSSD outputs go to OFF, but resulting in an object in the detection zone. The override function is used to clear the detection zone; the OSSD outputs are switched to ON, and it deliberately removes the object.

Under the override is activated, you can use the status indicators or external indicators (e.g., lamp output) to inform that the safety-related functions are deactivated.

The override function is automatically set when muting is activated. The override is initiated by the reset input.

※If override function is activated in the interlock condition, the interlock is released.

※When you use the override with blanking function, it operates like below.

- Fixed blanking: Fixed blanking is prioritized because the fixed object and the detection object cannot be distinguished.
- Floating blanking: Override is prioritized because the moving object and the detection object cannot be distinguished.

When you need to inform that the override function is activated, install an indicator light such as warning lamps in a place where it can be checked at all positions.



Warning

Follow the requirements described in this manual for the devices and installation method to use the override function.

For more information, please refer to laws, regulations and standards in the country or region.

Failure to follow these requirements, the functions and performance are not guaranteed.

It may result in personal injury.

- Override start conditions (All conditions are required.)
 - ix. Not lockout condition
 - x. The object is in the detection zone and the OSSD output is in OFF state.
 - xi. One or more mute input is in ON state.
 - xii. Reset input is in OFF state for more than override input time limit (T1).
 - xiii. The monitoring result of lamp output is normal.
(The output mode of lamp output should be set to Muting/Override.)

- Override end condition (One or more conditions are required.)
 - i. Enter lockout condition
 - ii. All mute inputs are in OFF state.
(In case of the exit-only muting mode, the override is deactivated after the exit-only muting wait time and cannot exceeds override timeout (T2).)
 - iii. All beams are clear and the muting end wait time is exceeded.
(This is only for the exit-only muting mode.)
 - iv. The duration of override period exceeds the override timeout (T2).
 - v. The reset input is switched to the ON state from the OFF state.
 - vi. The monitoring result of lamp output is abnormal.
(The output mode of lamp output should be set to Muting/Override.)

• Timing chart of override

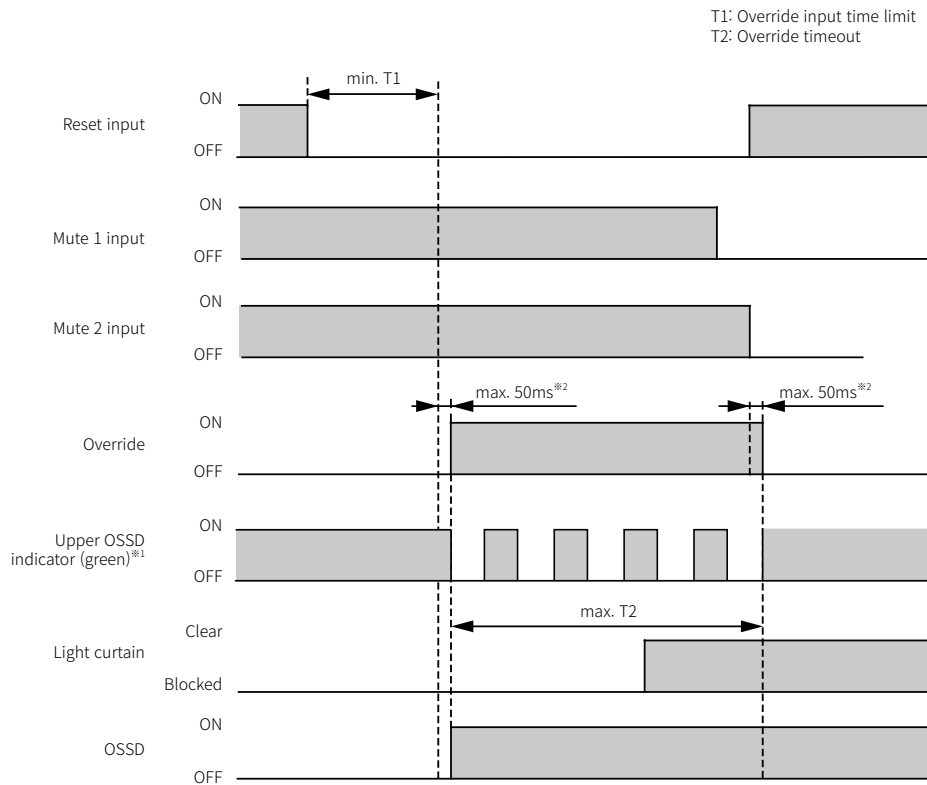

※1: The upper OSSD indicator flashes every 1 second.

※2: It may differ depending on the series connection.



Note

※The auxiliary output (AUX 1/2) or lamp output (Lamp 1/2) can display the override condition.
 For more information, see "6.5 Auxiliary output (AUX 1/2)", "6.6 Lamp output (Lamp 1/2)".

5.5.1 Wiring

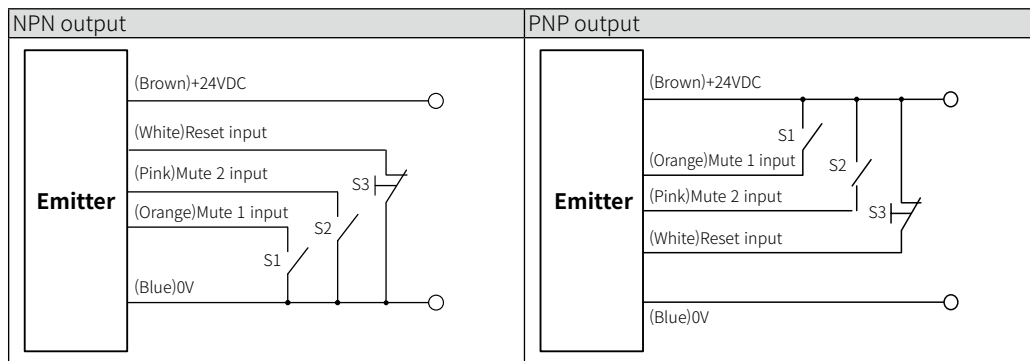

※Install override switch (S3) and muting sensors (S1, S2) to start override.

※Muting sensors (S1, S2) have the same output type (NPN, PNP) and 3-wire transistor output.
 Use sensors that output is ON when detecting an object, and operate in Dark ON mode.

※In case of SFL (standard type), use the muting sensors with N.O. contact.
 In case of SFLA (advanced type), use atLightCurtain to set N.O. or N.C. contact based on the output type of muting sensor.

5.5.2 Change settings

You can change settings via setting switch or atLightCurtain.
Only SFLA (advanced type) support atLightCurtain to change settings.

Function	Item	Setting range	Factory default	Setting method	
				atLightCurtain	Setting switch (pin no.)
Override	Override function	Enable/Disable	Disable	○	○(7)
	Input time limit (T1)	1-5sec	3sec		—
	Timeout (T2) ^{*1}	0-60sec	60sec		—

※The override function can be activated with the muting setting switch. Override is only available when the muting function is activated. (In case of advanced type, it can be activated separately.)

※If the function is activated by the setting switch, the setting range is the factory default.

※Override is applied to all beams regardless of the muting zone.

※1: If you set the Timeout (T2) to 0, it is set to 'unlimited' and it may cause continuous override condition unintentionally. In this case, the operator should perform a sufficient risk assessment and take additional safety measures.

5.6 Blanking

If an attached or fixed object is in the detection zone, resulting in the OFF state of OSSD continuously, you can set the blocked beams as a blanking zone. The blanking function will not detect an object and allows the OSSD output to be maintained ON state. Only the SFLA series (advance type) supports this function.

Use the blanking function only in an environment where the object remains.

Set the blanking zone via atLightCurtain in the order below

- i. Activate the blanking function before selecting fixed or floating blanking.
- ii. Set the blanking zone via manual or automatic setting
- iii. Set the number of beams to be the blanking zone



Warning

After setting the blanking function, check that it operates as intended.

Failure to follow this instruction may result in personal injury due to undetected human body.

5.6.1 Fixed blanking

If certain beams are continuously blocked by a fixed object or materials, set the blanking zone using the fixed blanking .

You can set fixed blanking zone via atLightCurtian. The zone is available up to three zones to set.

However, if you want to set multiple zones, do not overlap the beams. The adjacent beams are available to use for the fixed blanking zone.

In the series connection, the fixed blanking zone cannot be set to extend between the sets of light curtains.



Note

- ※If you use the fixed blanking with the muting function, the muting zone and fixed blanking zone can be overlapped. In case of the overlapped zone, when muting begins, the blanking is maintained and follows blanking error mode.
- ※If you use the fixed blanking with the override function, when override begins, the blanking is maintained and follows blanking error mode.

(1) How to deal with fixed blanking error

All beams of blanking zone must be blocked. You can select one of the error modes when the beams are clear.

Error mode	OSSD	Description
Lockout	OFF	The light curtain enters the lockout condition. After fixing an error of the blanking zone, reset the lockout condition. The OSSD outputs are switched to ON state.
Warning	OFF	The status indicator displays the warning. After fixing an error of the blanking zone, reset the warning state. The OSSD outputs are switched to ON state.

(2) Set tolerance

Set the tolerance that allows an object of a size greater than the detection capability. It helps to prevent fixed blanking error, resulting from the shake or vibration of beams at both ends of the blanking zone. Even if the tolerance is not blocked, the OSSD outputs maintain ON state.

The tolerance can be set separately in each zone. The maximum number of tolerance as follows.

Number of beams	Tolerance
1	0
2	1
More than 3	2

- The detection capability based on the tolerance

Setting item		Changed item		
Number of beams	Tolerance	Detection capability in the fixed blanking zone (optical axis pitch)		
		Ø14mm (9mm)	Ø20mm (15mm)	Ø30mm (25mm)
1	0	Ø14mm	Ø20mm	Ø30mm
	1	Ø23mm	Ø35mm	Ø55mm
2	0	Ø14mm	Ø20mm	Ø30mm
	1	Ø23mm	Ø35mm	Ø55mm
	2
N	0	Ø14mm	Ø20mm	Ø30mm
	1	Ø23mm	Ø35mm	Ø55mm
	2

(3) Example of fixed blanking

(●: Blanking beams, ○: Tolerance, ●: Overlapped beams)

- Requirements for the fixed blanking zone
 - i. Set each blanking zone not to overlap.

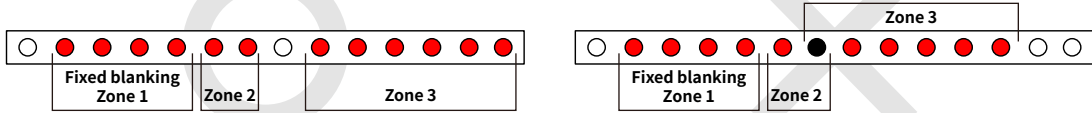

- ii. When setting the tolerance, make sure that the zones are not adjacent to each other. (In case of the zones with the tolerance, each zone has to be located at least one beam apart. Zone 1 and zone 2 can be adjacent, but zone 2 and zone 3 cannot be adjacent.)

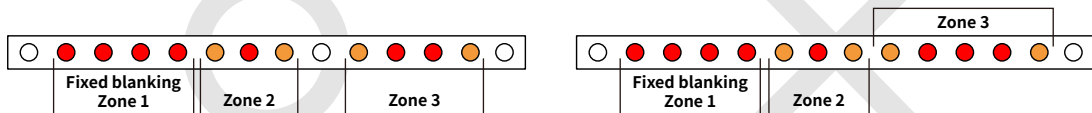

- iii. Do not set the tolerance at both ends of the light curtain.

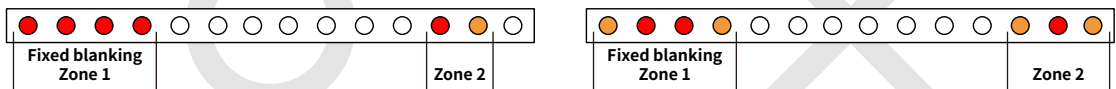

- When setting the tolerance in fixed blanking zone

- i. If the tolerance is not set, when beams of fixed blanking zone are clear, it follows the error mode you set. (number of fixed blanking beam: 3, tolerance: 0)

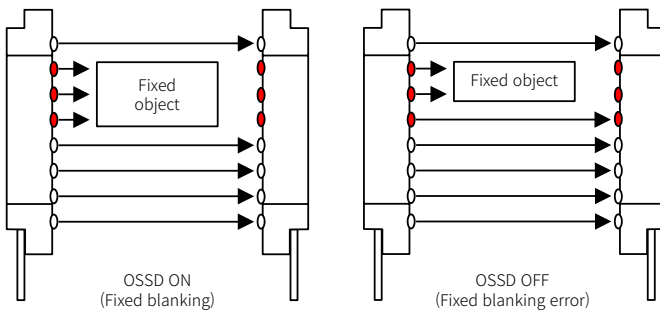

- ii. If the tolerance is set, when beams of fixed blanking zone are clear, it follows the error mode you set. (number of fixed blanking beam: 4, tolerance: 2)

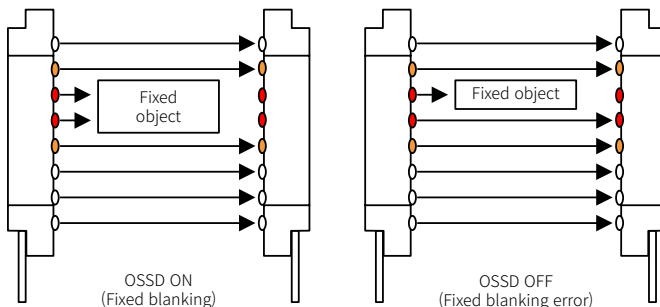

iii. If the tolerance is set to 1, the tolerance can be set at either end of the blanking zone.

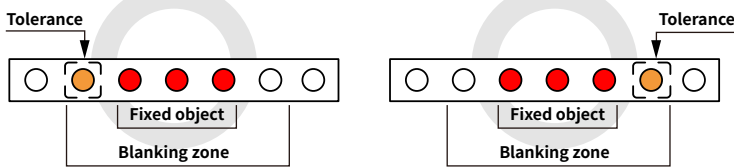

iv. The tolerance cannot be set to two continuous beams.

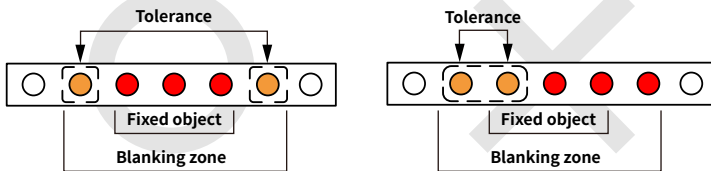

v. The tolerance can be set in each fixed blanking zone. The tolerance cannot be adjacent to each other.

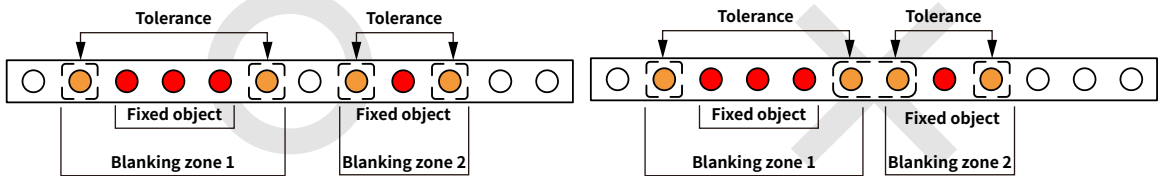

5.6.2 Floating blanking

Floating blanking is a function that the blanking zone follows the location of a moving object.

You can set the floating blanking zone via atLightCurtain. Only one zone consisting of continuous beams is available to set. However, if you want to use the floating blanking with the fixed blanking function, do not overlap the zones.

You can set one floating blanking zone with the beams out of the fixed blanking zone.

In the series connection, be sure to set only one zone within the one set of light curtain, and cannot extend it between the sets.



Note

※If you use the floating blanking with the muting function, the muting zone and floating blanking zone can be overlapped. In case of the overlapped zone, when muting begins, the blanking is deactivated and activated again after the muting ends.

※If you use the floating blanking with the override function, when override begins, the blanking is deactivated and activated again after the muting ends.

(1) How to deal with floating blanking error

You can select one of the error modes when the beams are clear.

Error mode	OSSD	Description
Lockout	OFF	The light curtain enters the lockout condition. After fixing an error of the blanking zone, reset the lockout condition. The OSSD outputs are switched to ON state.
Warning	OFF	The status indicator displays the warning. After fixing an error of the blanking zone, reset the warning state. The OSSD outputs are switched to ON state.

(2) Set tolerance

Set the tolerance that allows an object of a size greater than the detection capability. It helps to prevent floating blanking error, resulting from the shake or vibration of beams at both ends of the blanking zone. Even if the tolerance is not blocked, the OSSD outputs maintain ON state. If you set the number of floating beams more than two, be sure to set tolerance to make a room for moving object. If you set the number of floating beams to one, you cannot set the tolerance.

The maximum number of tolerance and changed detection capability as follows.

Setting item		Changed item				
Floating beams	Tolerance	Min value of floating beams ^{※1}	Effective blocked beams ^{※2}	Changed detection capability ^{※3}		
				Ø14mm	Ø20mm	Ø30mm
1	0	1	2	Ø23mm	Ø35mm	Ø55mm
2	0	2	3	Ø32mm	Ø50mm	Ø80mm
	1	1-2				
3	0	3	4	Ø41mm	Ø65mm	Ø105mm
	1	2-3				
	2	1-3				
4	0	4	5	Ø50mm	Ø80mm	Ø130mm
	1	3-4				
	2	2-4				
	3	1-4				
5	0	5	6	Ø59mm	Ø95mm	Ø155mm
	1	4-5				
	2	3-5				
	3	2-5				
	4	1-5				
...
15	0	15	16	Ø149mm	Ø245mm	Ø405mm
	1	14-15				
	2	13-15				
	3	12-15				
	4	11-15				
	5	10-15				
N(1-15)	N _r (0-5)	(N-N _r)-N	N+1	14+(9×N)	20+(15×N)	30+(25×N)

※1: A condition of the minimum number of beams to keep the OSSD output in ON state, if the number of continuously blocked beams in floating blanking zone is less than the minimum number of floating beams, causing a blanking error. Be sure to configure the floating blanking zone to meet the condition below.
[min value of floating beams] = [floating beams] - [tolerance]

※2: The condition of number of beams that OSSD output is switched to OFF state when light curtain is blocked.

※3: It is determined by physical optical axis pitch and changed detection capability after applying blanking function.

※If no zone is specified, floating blanking is unapplied, and the detection capability keeps the factory defaults.

(3) Example of floating blanking

Example condition	
Floating blanking zone	8 (entire beams)
Floating beams	3
Tolerance	1
Min value of floating beams	2 (2 to 3)

i. The OSSD output is maintained ON state if the min value of floating beams or floating beams is satisfied.

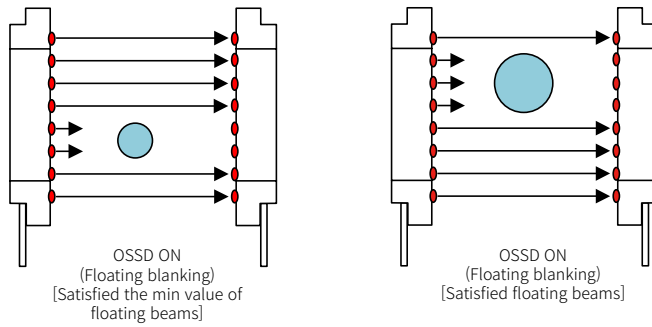

ii. The OSSD output is switched to OFF state if the number of blocked beams is less than the min value of floating beams or beams are blocked discretely. It follows the error mode you set.

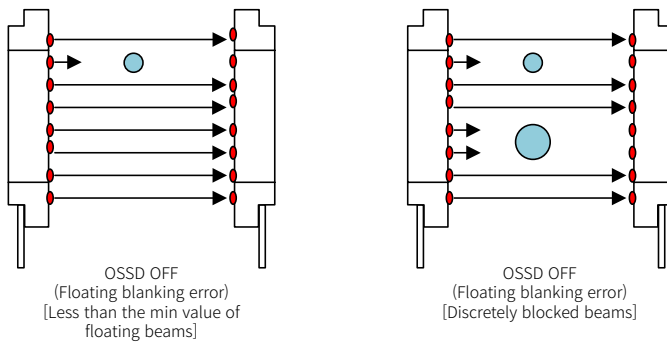

5.6.3 Use the floating blanking with fixed blanking zone

(●: fixed blanking beams, ●: floating blanking beams, ●: tolerance, ●: overlapped beams)

Both fixed blanking and floating blanking zone can be set at the same time.

i. Make sure that the zones of fixed blanking and floating blanking do not overlap.

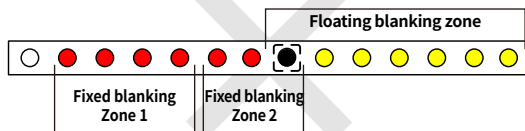

ii. When you set the tolerance in the fixed blanking zone, leave space with one or more beams between each zone.

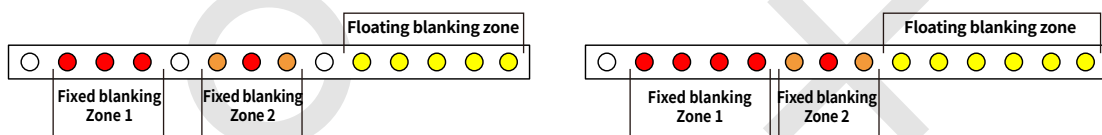

5.6.4 Change settings

Only SFLA (advanced type) support atLightCurtain to change settings.

Function	Setting item		Setting range	Factory default	Setting item	
					atLightCurtain	Setting switch
Fixed blanking	Fixed blanking function		Enable/Disable	Disable	○	—
	1-3 zones	Fixed blanking zone ^{※1}	Range of beams	None		
		Tolerance	0-2	0		
		Error mode ^{※2}	Warning/Lockout	Warning		
Floating blanking	Floating blanking function		Enable/Disable	Disable		
	1 zone	Floating blanking zone ^{※1}	Range of beams	None		
		Floating beams	1-15	1		
		Tolerance	0-5	0		
		Error mode ^{※2}	Warning/Lockout	Warning		

※1: The OSSD output is maintained ON state when beams of blanking zone are blocked.

If you use the blanking with the muting function, the muting zone and blanking zone can be overlapped.

Set the blanking zone via manual or automatic setting in atLightCurtain.

For more information, see "*atLightCurtain User Manual*."

※2: The error mode can be set as warning or lockout, see "*atLightCurtain User Manual*."

5.7 Reduced resolution

Reduced resolution is a function that changes the detection capability of the light curtain. Even if the light curtain is blocked by the moving objects with a diameter smaller than the changed detection capability are ignored in the detection zone, resulting in the OSSD output is maintained ON state.

Only the SFLA series (advanced type) supports this function.

Reduced resolution can be set to entire detection zone via atLightCuratin, and number of ignored beams can be set from one to three. However, this function cannot be used with the muting or blanking function.



Warning

If you use the reduced resolution function, the detection capability will be larger. Calculate the safety distance suitable for the minimum detection capability to secure minimum safety distance.

See the formula below for changed detection capabilities.

- Changed detection capability = existing detection capability + (optical axis pitch × number of ignored beams)

Detection capability	Setting item	Changed item	
	Number of ignored beams	Changed detection capability	Effective blocked beams (OSSD OFF)
Ø14mm	—	Ø14mm	1
	1	Ø23mm	2
	2	Ø32mm	3
	3	Ø41mm	4
Ø20mm	—	Ø20mm	1
	1	Ø35mm	2
	2	Ø50mm	3
	3	Ø65mm	4
Ø30mm	—	Ø30mm	1
	1	Ø55mm	2
	2	Ø80mm	3
	3	Ø105mm	4

※Even if the size of object smaller than ignored beams is removed, the condition of light curtain is not changed to warning or lockout and the OSSD outputs maintain ON state.

※The OSSD output is switched based on the largest zone among the blocked zones, so that OSSD output maintains ON state when the beams are discretely blocked by the object smaller than the ignored beams.

(1) Setting example

- When the number of ignored beams is two
 - The OSSD output remains ON state when the reduced resolution is activated and two beams are blocked.

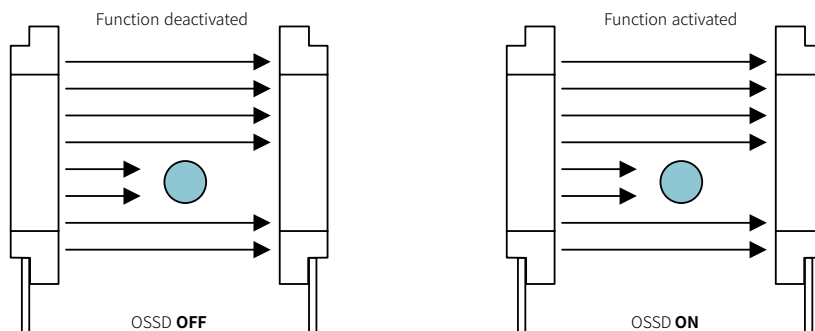

ii. The OSSD output remains ON state when the number of discretely blocked beams is less than the ignored beams.

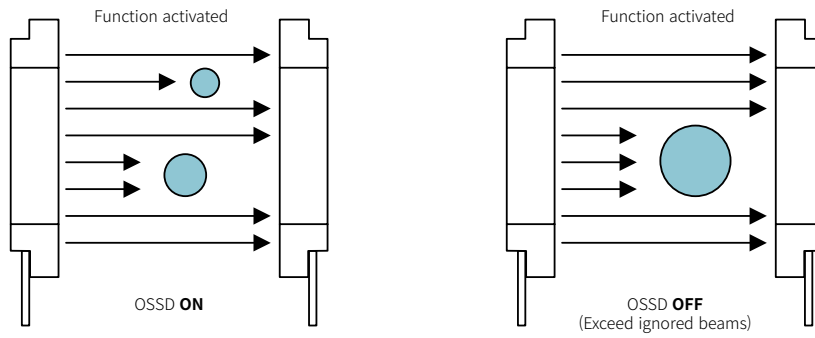

(2) Setting example of series connection

In case of the series connection, the number of ignored beams set by the master is applied to the slaves. The figure below is an example when the ignored beams are two.

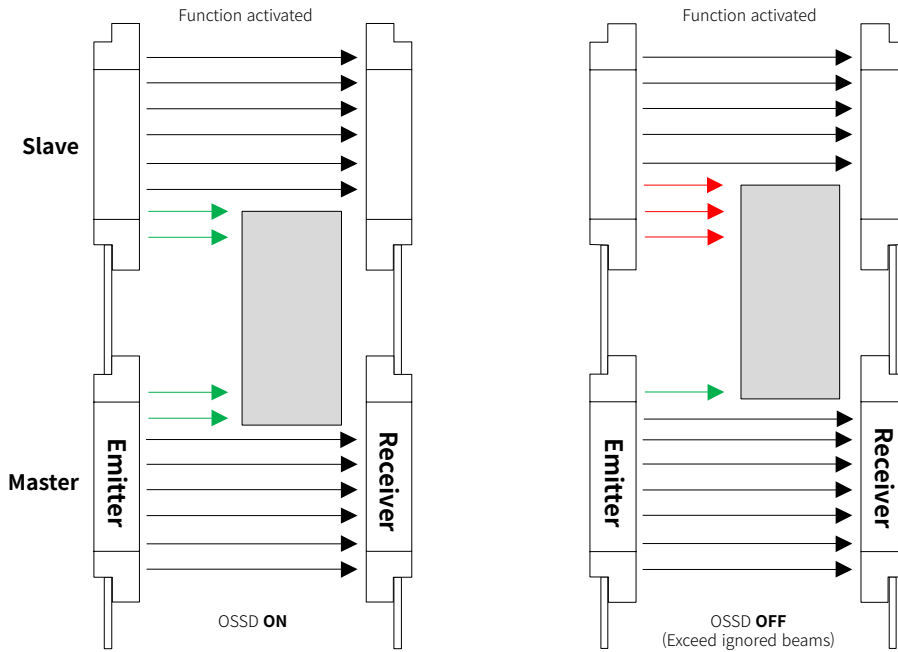

5.7.1 Change settings

Only SFLA (advanced type) supports atLightCurtain to change settings.

Function		Setting range	Factory default	Setting item	
				atLightCurtain	Setting switch
Reduced resolution	Reduced resolution function	Enable/Disable	Disable	○	—
	Ignored beams	1-3	1		

※The reduced resolution cannot be set with the muting and blanking function, be sure to activate the reduced resolution only when these are deactivated.

※As the detection capability is changed, calculate the safety distance again to ensure the minimum safety distance.

6. Other functions

6.1 Series connection

If you need to extend the detection zone, connect the light curtains via series connection cable to use two or more emitter and receivers as one product. (sold separately, SFL-EC□T, SFL-EC□R)

It can be extended up to max. 3 sets / 300 beams for SFL and up to max. 4 sets / 400 beams for SFLA.

The operation and control of light curtains in series connection are synchronized with the settings of the master.

For example, if any light curtain is blocked, the OSSD outputs of all light curtains are switched to OFF state.

If a product failure occurs, all light curtains enter the lockout condition.

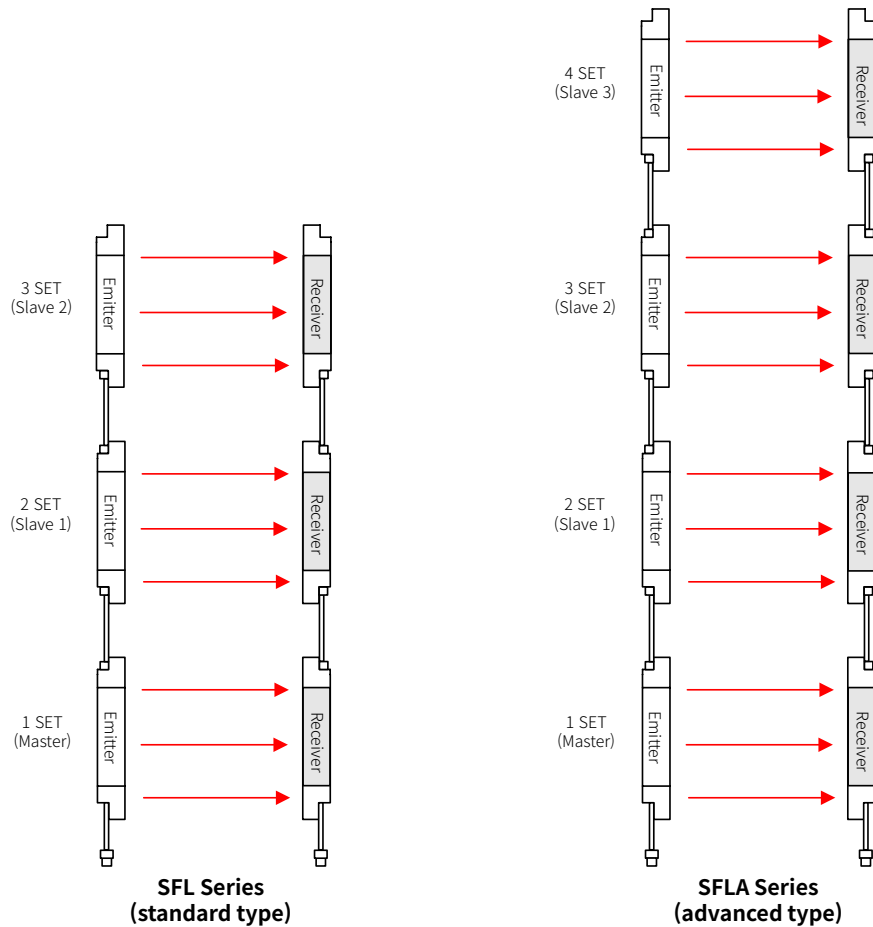

※There is no mutual interference prevention in series connection.

※When the maximum number of connected light curtains or beams is exceeded, entering the lockout condition.

※In series connection, the response time (T_{ON} , T_{OFF}) can be changed depending on the installed SET.
For more information, see "2.2 Models"

※The status of the light curtain in series connection is displayed on the 7-segment LEDs of each set in the same way.
However, in case of warning or error condition, all sets enter the lockout condition and it is displayed at the 7-segment LEDs of light curtain where the error or warning has occurred.
The information on error and warnings is saved for each set, you can check it via atLightCurtain.

(1) Example settings of series connection

• Be sure to check the following details if you use the series connection.

- ①: Light curtain with different detection capability or number of beams can be connected.
- ②: A combination of the SFL (standard type) and SFLA (advanced type) is unavailable.
- ③: A combination of emitter and receiver causes the lockout condition. Be sure to connect in the form of an emitter - emitter and a receiver - receiver.
- ④: Use same model per set.

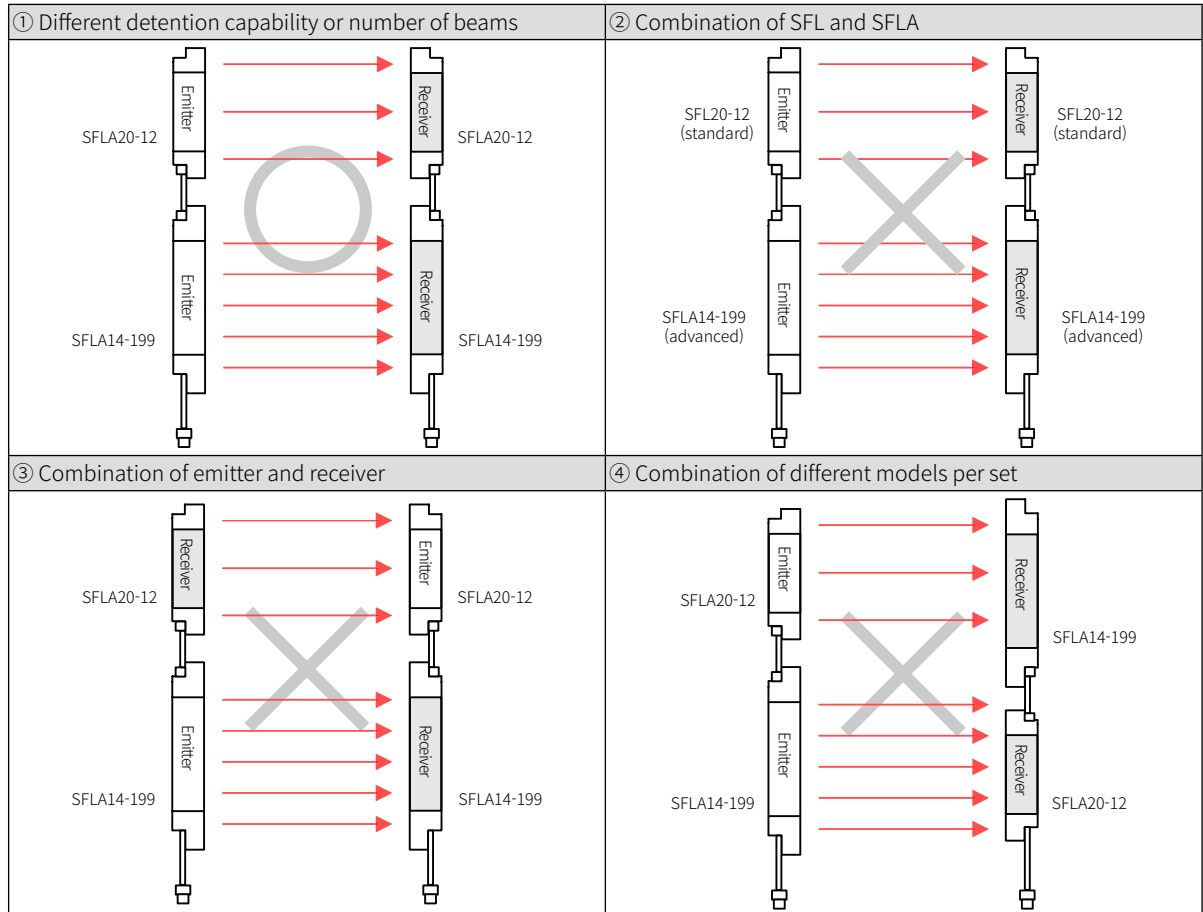

※If connection is incorrect, interpreting as settings error and entering the lockout condition. In this case, the communication error, end cap error, and series connection error may occur in multiple sets at the same time. Check the wiring connection, end cap, and lamp output.

(2) Maximum allowable length for series connection

Make sure that the total length of the light curtain, the power I/O cable, and the series connection cable should not exceed 35m. However, the total length of the connector cable and the power I/O cable is up to 20m.

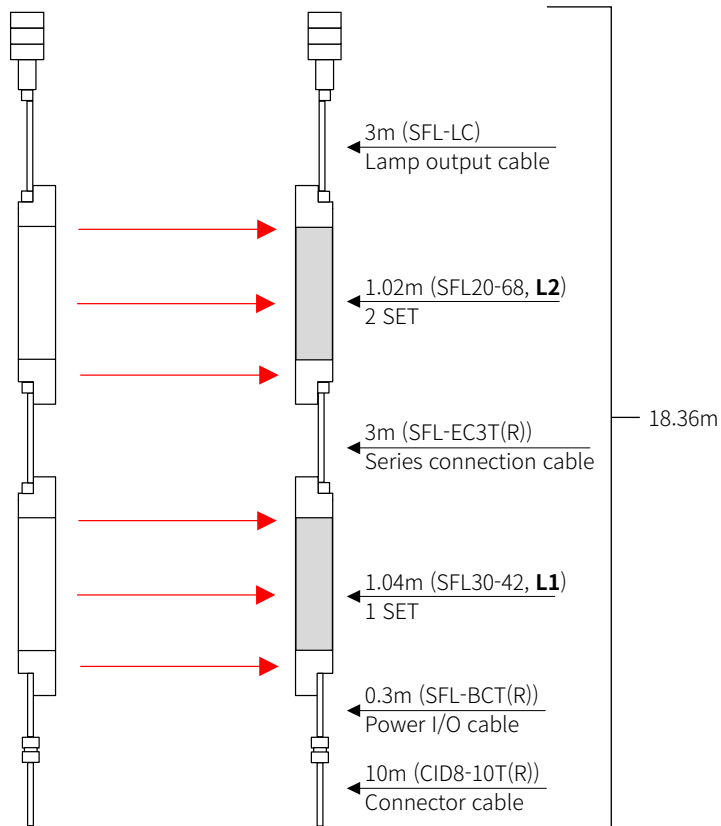

Connector cable + Power I/O cable + Series connection cable + Lamp output cable + length of the light curtain(**L1+L2**) = 18.36m

6.2 Change sensing distance

It is the function to change the sensing distance to meet installation environment. If you change the sensing distance, there is an effect to mutual interference.

(1) Sensing distance

Mode	Detection capability	Sensing distance
Long mode	Finger	0.2-10m
	Hand, Hand-Body	0.2-15m
Short mode	Finger	0.2-5m
	Hand, Hand-Body	0.2-8m

(2) Setting example of sensing distance

Long mode → Short mode

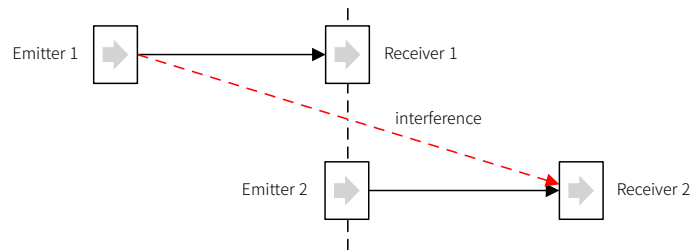

↓
Mutual interference is reduced when setting the short mode.

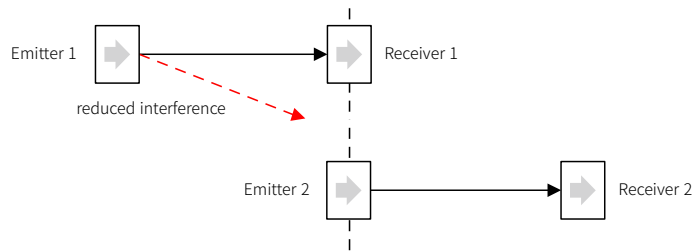

6.2.1 Change settings

You can change the mode via setting switch or atLightCurtain. Only SFLA (advanced type) support atLightCurtain to change settings.

Function	Setting range	Factory default	Setting method	
			atLightCurtain	Setting switch (pin no.)
Sensing distance	Long/Short	Long	○	○(2)

※In the series connection, all slaves operate based on the settings of master.

6.3 Set NPN or PNP

You can set input/output of OSSD, auxiliary output (AUX 1, 2), and lamp output (Lamp 1/2).

The ON or OFF state of input is determined by the output polarity.

In the NPN output, the status indicator is turned on. In the PNP output, the status indicator is turned off.

(1) When setting the NPN output

- ON voltage: 0-3VDC \equiv
- OFF voltage: 9-24VDC \equiv or open

(2) When setting the PNP output

- ON voltage: 9-24VDC \equiv
- OFF voltage: 0-3VDC \equiv or open

6.3.1 Setting change

You can change the mode via setting switch or atLightCurtain.

Only SFLA (advanced type) support atLightCurtain to change settings.

Function	Setting range	Factory default	Setting method	
			atLightCurtain	Setting switch (pin no.)
Output polarity	NPN/PNP	PNP	○	○(1)

※In series connection, all slaves operate based on the settings of master.

※For more information on external input and output based on the output polarity, see "2. Specifications"

※For more information on I/O circuit diagrams based on the output polarity, see "7. Wiring"

6.4 External test

The external test is a function for; When the test signal is applied from the outside of the light curtain, it forcibly stops light emission and checks whether the safety system stops correctly.

If the light emission stops, the light curtain is blocked, resulting in OSSD output is switched to the OFF state until the test input is released. The emitter operates again when the test input is released.

If the restarted interlock is activated, entering interlock condition. The status indicator turns on when the test signal is applied. The status indicator turns off when the test signal is released.

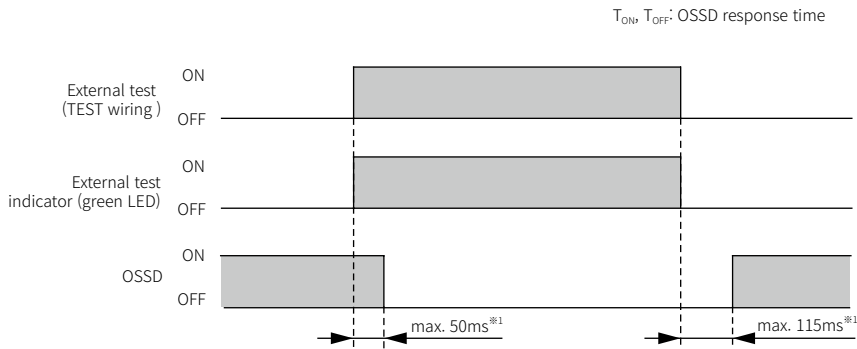

※1: It may differ depending on the series connection.

※The external test function is to test the emission function of the product, it cannot be used as the safety-related function.

※In the series connection, if the external test signal is applied, the emission function of all sets stops.

6.4.1 Wiring

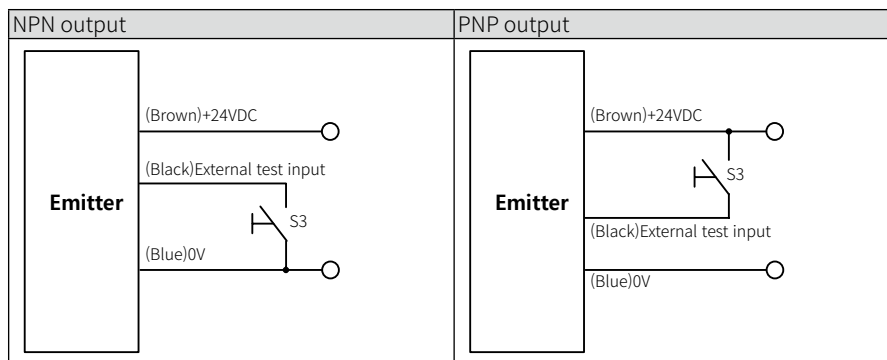

Note

※Install a switch (S3) for external test and use the switch with N.O. contact.

※If no switch is installed, be sure to connect directly the external test input to +24VDC for NPN output or 0V for PNP output.

6.5 Auxiliary output (AUX 1/2)

The auxiliary output is an optional output for monitoring the status of the light curtain. It is provided at the bottom of the emitter and receiver.

Do not use the auxiliary output for safety purposes. This output cannot be deactivated.

(1) Example of output mode

※Example is based on the factory default.

- AUX 1(receiver) - output mode: OSSD, output phase: Reverse
- AUX 2(emitter) - output mode: Error/Lockout, output phase: Reverse

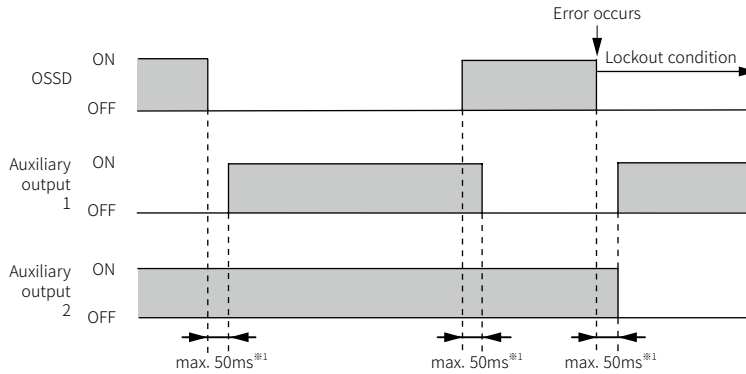

※1: It may differ depending on the series connection.

(2) Set auxiliary output mode

Select the output mode first and select the output phase. The output may differ depending on the output phase in the same output mode. If the output phase is set to reverse, the output is switched to ON from OFF. If the output phase is normal, the output is switched to OFF from ON.

The output mode and phase can be set via atLightCurtain. The SFLA (advanced type) supports atLightCurtain. In case of the output mode of SFL (standard type), AUX 1 (receiver) is OSSD ON/OFF, and AUX 2 (emitter) is Error/Lockout.

No.	Output mode	Description	Output phase	
			Reverse	Normal
1	OSSD ON/OFF	The OSSD output is in the ON state.	OFF	ON
2	Error / Lockout	The light curtain is in the error or lockout condition.		
3	Warning	The light curtain is in the warning condition.		
4	Muting / Override	The muting or override function is activated.		
5	Blanking	The blanking function is activated.		
6	Blanking Error	All beams of fixed or floating blanking zone are not blocked.		
7	External Test	The external test input is in the ON state.		
8	Interlock	The interlock function is activated.		
9	Reset-Hold	The light curtain is in the reset-hold wait time.		
10	Light ON/OFF	All beams are clear and stable.		
11	Sensitivity Reduction ^{*1}	The incident light level is less than the sensitivity reduction level.		

※1: Sensitivity reduction occurs when the current incident light level lasts for 30 minutes, with less than 15% to 35% of the maximum incident light level.

For more information on the incident light level, see "4.3 Alarm for incident light level"

※The OSSD output is switched to the OFF to prevent damage in the output circuit if the current over rated voltage flows in the auxiliary output. The state maintains until the auxiliary output is switched depending on the sensing or functional operation.

6.5.1 Wiring

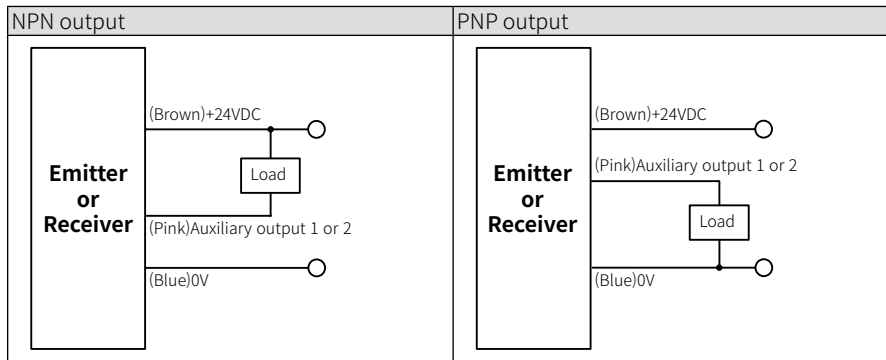

※Auxiliary output (AUX 1) is provided to the receiver, and auxiliary output (AUX 2) is provided to the emitter.
 ※In case of series connection, the auxiliary output can be used only in the emitter and receiver of master set.

6.5.2 Setting change

The auxiliary output cannot be deactivated. You can change the mode via setting switch or atLightCurtain.
 Only SFLA (advanced type) support atLightCurtain to change settings.

Function	Setting item	Setting range	Factory default	Setting method	
				atLightCurtain	Setting switch
Auxiliary output 1 (AUX 1, receiver)	Output mode	※1	OSSD	○	—
	Output phase	Reverse/Normal	Reverse		
	Output pattern ^{※2}	Light ON/Flashing	Light ON		
Auxiliary output 2 (AUX 2, emitter)	Output mode	※1	Error/Lockout		
	Output phase	Reverse/Normal	Reverse		
	Output pattern ^{※2}	Light ON/Flashing	Light ON		

※1: For more information on output mode, see "(2) Set auxiliary output mode".
 ※2: If the output pattern is set to flashing, it flashes every 0.5 sec.

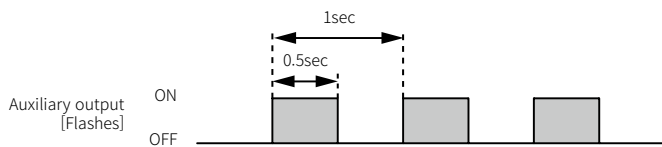

※When the muting is activated, the auxiliary output (AUX 2) of emitter cannot be used.

6.6 Lamp output (Lamp 1/2)

The lamp output is an optional output for monitoring the status of light curtain such as short-circuit, and disconnection of the load, damage and overcurrent. It is provided at the top of the emitter and receiver.

After removing the end cap, the dedicated cable (sold separately, SFL-LC) can be connected.

Do not use the lamp output for safety purposes. To activate the lamp output, you must remove the end cap.

(1) Example of output mode

※Example is based on the factory default.

- Lamp 1 (receiver) - Output mode: Muting/Override, Output phase: Normal
- Lamp 2 (emitter) - Output mode: Muting/Override, Output phase: Normal

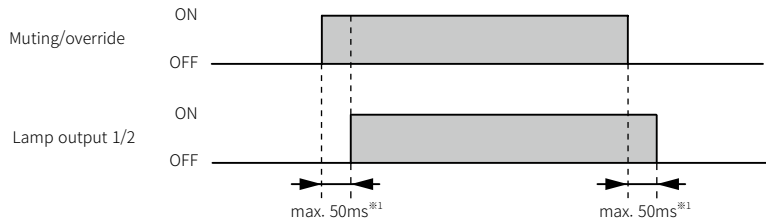

※1: It may differ depending on the series connection.

(2) Set lamp output mode

Select the output mode first and select the output phase. The output may differ depending on the output phase in the same output mode. If the output phase is set to reverse, the output is switched to ON from OFF. If the output phase is normal, the output is switched to OFF from ON.

The output mode and phase can be set via atLightCurtain. The SFLA (advanced type) supports atLightCurtain. In case of the output mode of SFL (standard type) is Muting/Override.

No.	Output mode	Description	Output phase	
			Reverse	Normal
1	OSSD ON/OFF	The OSSD output is in the ON state.	OFF	ON
2	Error / Lockout	The light curtain is in the error or lockout condition.		
3	Warning	The light curtain is in the warning condition.		
4	Muting / Override	The muting or override function is activated.		
5	Blanking	The blanking function is activated.		
6	Blanking Error	All beams of fixed or floating blanking zone are not blocked.		
7	External Test	The external test input is in the ON state.		
8	Interlock	The interlock function is activated.		
9	Reset-Hold	The light curtain is in the reset-hold wait time.		
10	Light ON/OFF	All beams are clear and stable.		
11	Sensitivity Reduction ^{※1}	The incident light level is less than the sensitivity reduction level.		

※1: Sensitivity reduction occurs when the current incident light level lasts for 30 minutes, with less than 15% to 35% of the maximum incident light level.

For more information on the incident light level, see "4.3 Alarm for incident light level"



If the output is muting/override mode, you can use an external indicator to monitor the state of muting or override. Use an industrial lamp with the following specifications for the muting or override lamp.

- Incandescent lamp: 24VDC, 3-7W
- LED indicator: 50-300mA

(3) How to handle a lamp output error

You can set one of three error modes of lamp output via atLightCurtain.

For more information on error and warnings, see "11. Troubleshooting"

Error mode	Description
Lockout	The OSSD output is switched to OFF state and the light curtains enter the lockout condition. The status indicator shows the state. After the lockout is reset, the OSSD output is switched to ON state. The status indicator goes to the normal state.
Warning	The OSSD output depends on the status of light curtains. The status indicator shows a warning state. After fixing the error, the status indicator goes to the normal state.
None	The OSSD output depends on the status of light curtain and operates normally.

6.6.1 Wiring

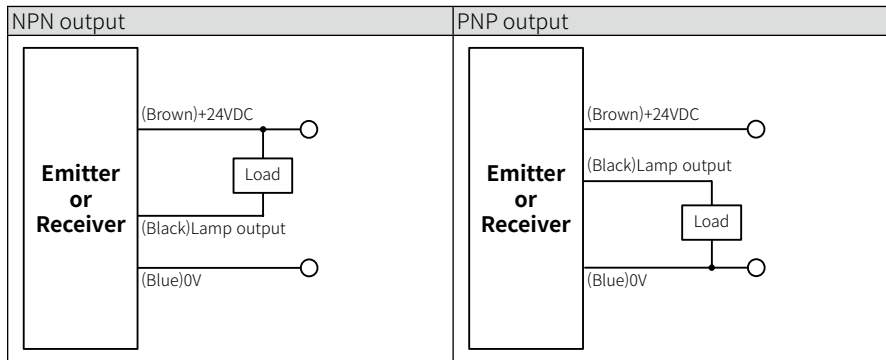

- ※Lamp output 1 (Lamp 1) is provided at the receiver and lamp output 2 (Lamp 2) is provided at the emitter.
- ※If you use the lamp output, the response time can be increased as much as 0.6ms.
- ※When the output mode is set to muting / override, install an external indicator (commercial lamp) at a position where it can be checked in any directions.
- ※In series connection, the lamp output can be used only on the emitter and receiver of the last slave.
- ※If an error occurs while muting is activated, the muting does not begin or ends, and enter the warning condition.

6.6.2 Setting change

You can change the modes via setting switch or atLightCurtain. atLightCurtain is only available on SFLA (advanced type).

Function	Setting item	Setting range	Factory default	Setting method	
				atLightCurtain	Setting switch (pin no.)
Lamp output 1 (Lamp 1, receiver)	Lamp output 1	Enable/Disable	Disable	○	○(7)
	Output mode	※1	Muting/Override		—
	Output phase	Reverse/Normal	Normal		—
	Output pattern ^{※2}	Light ON/Flashing	Light ON		—
	Error mode	Warning/Lockout/None	Lockout		—
Lamp output 2 (Lamp 2, emitter)	Lamp output 2	Enable/Disable	Disable	○	○(7)
	Output mode	※1	Muting/Override		—
	Output phase	Reverse/Normal	Normal		—
	Output pattern ^{※2}	Light ON/Flashing	Light ON		—
	Error mode	Warning/Lockout/None	Lockout		—

- ※The lamp out can be activated via the muting setting switch.
- ※1: For more information on the output mode, see "(2) Set lamp output mode"
- ※2: When output pattern is set to flashing, it flashes every 0.5 sec.

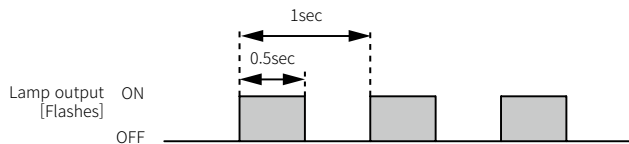

7. Wiring

7.1. I/O connection diagram

7.1.1 Input circuit diagram

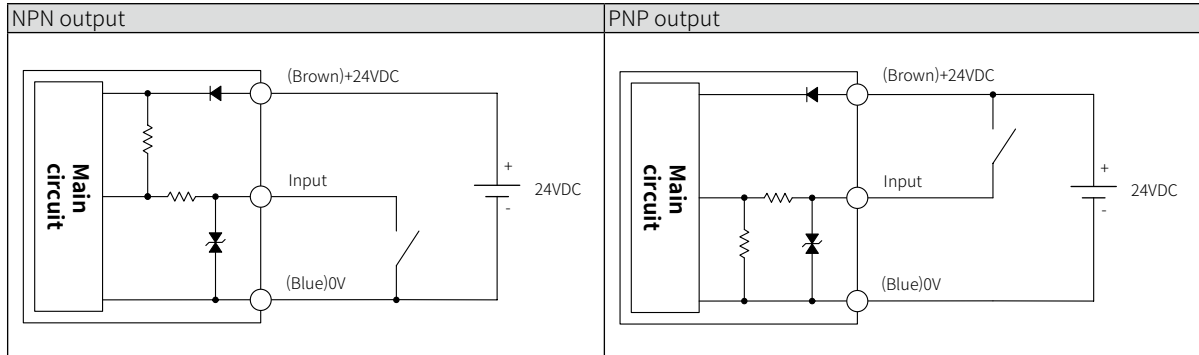

7.1.2 Output circuit diagram

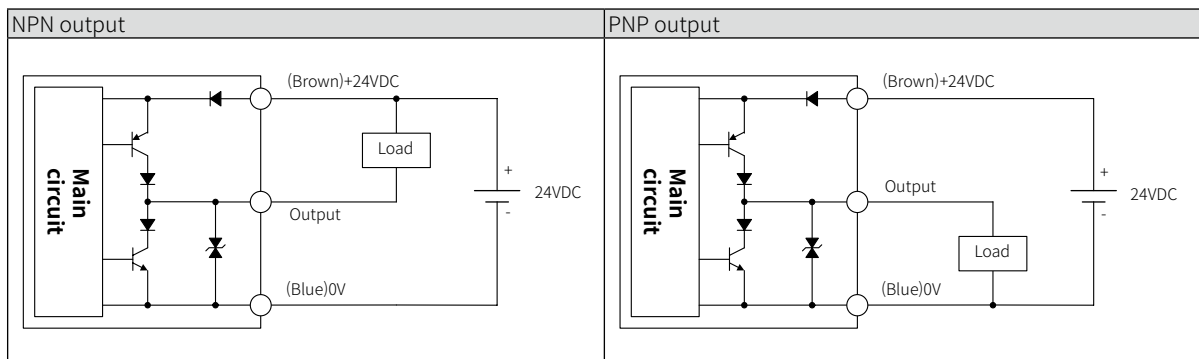

Note

- ※If there is a potential malfunction due to noise, combine a protection circuit to the input wiring, or connect a device with a protection circuit and apply the signal.
- ※When using PNP output, be sure to connect the load between the OSSD output wire and 0V. Do not short the OSSD output wires to +24V.
Incorrect wiring or shut down of the power supply is dangerous because the OSSD output is always in ON state.
- ※When using NPN output, be sure to connect the load between the OSSD output wire and +24V. Do not short the OSSD output wires to 0V.
Incorrect wiring or shut down of the power supply is dangerous because the OSSD output is always in ON state.
- ※Do not connect, repair, inspect, or replace the unit while it is connected to the power source.
Failure to follow this instruction may cause malfunction or danger due to the safety-related function that does not operate properly.
- ※Use a separate power supply for the load and the product, and do not exceed the specified ratings.
Failure to follow this instruction may result in damage or malfunction of the product.

7.2 Example of wiring diagram

EDM	Interlock	Reset-hold	Muting
Disable	Disable (auto reset)	Disable	Disable

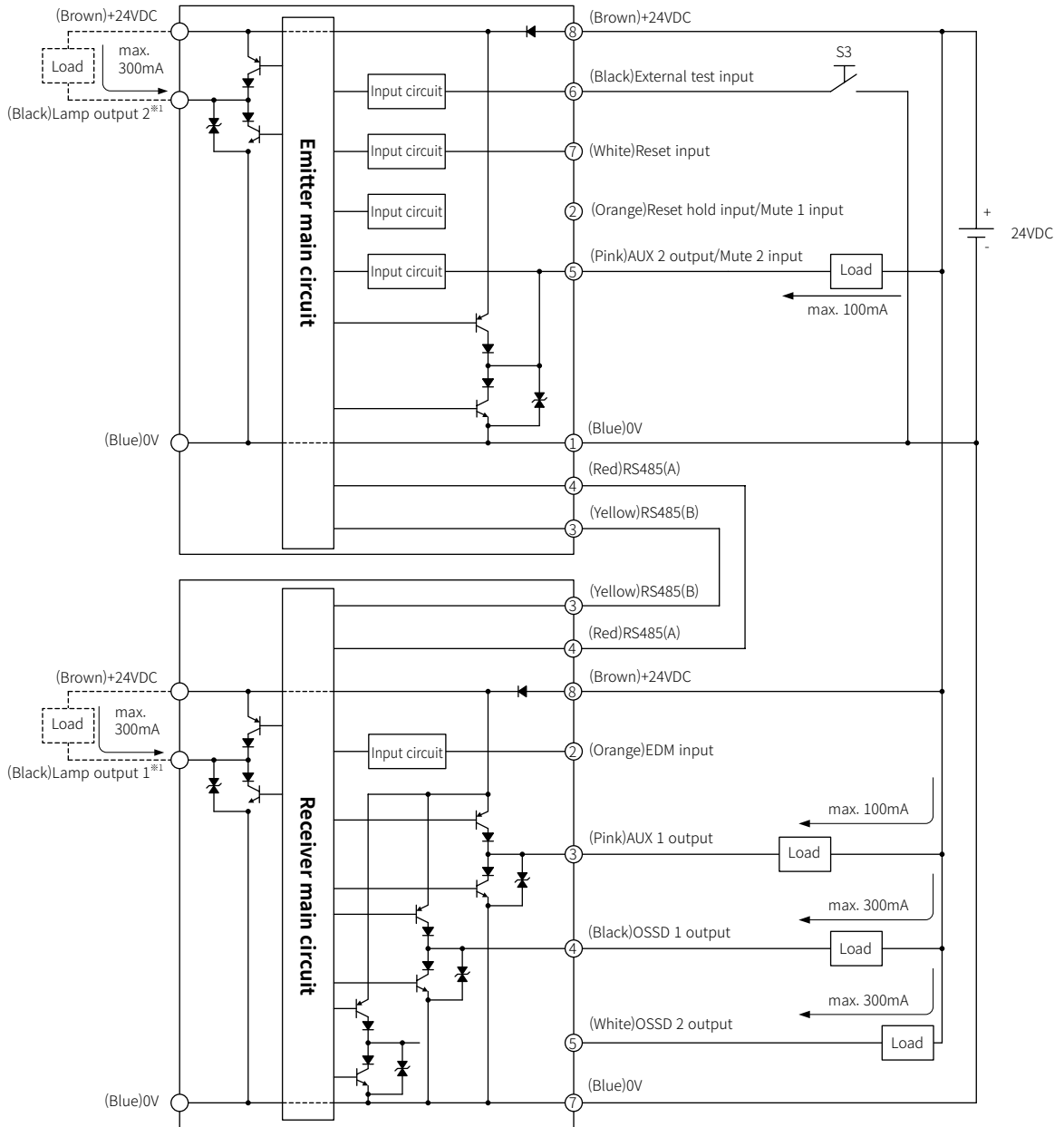
(1) NPN output



(2) PNP output

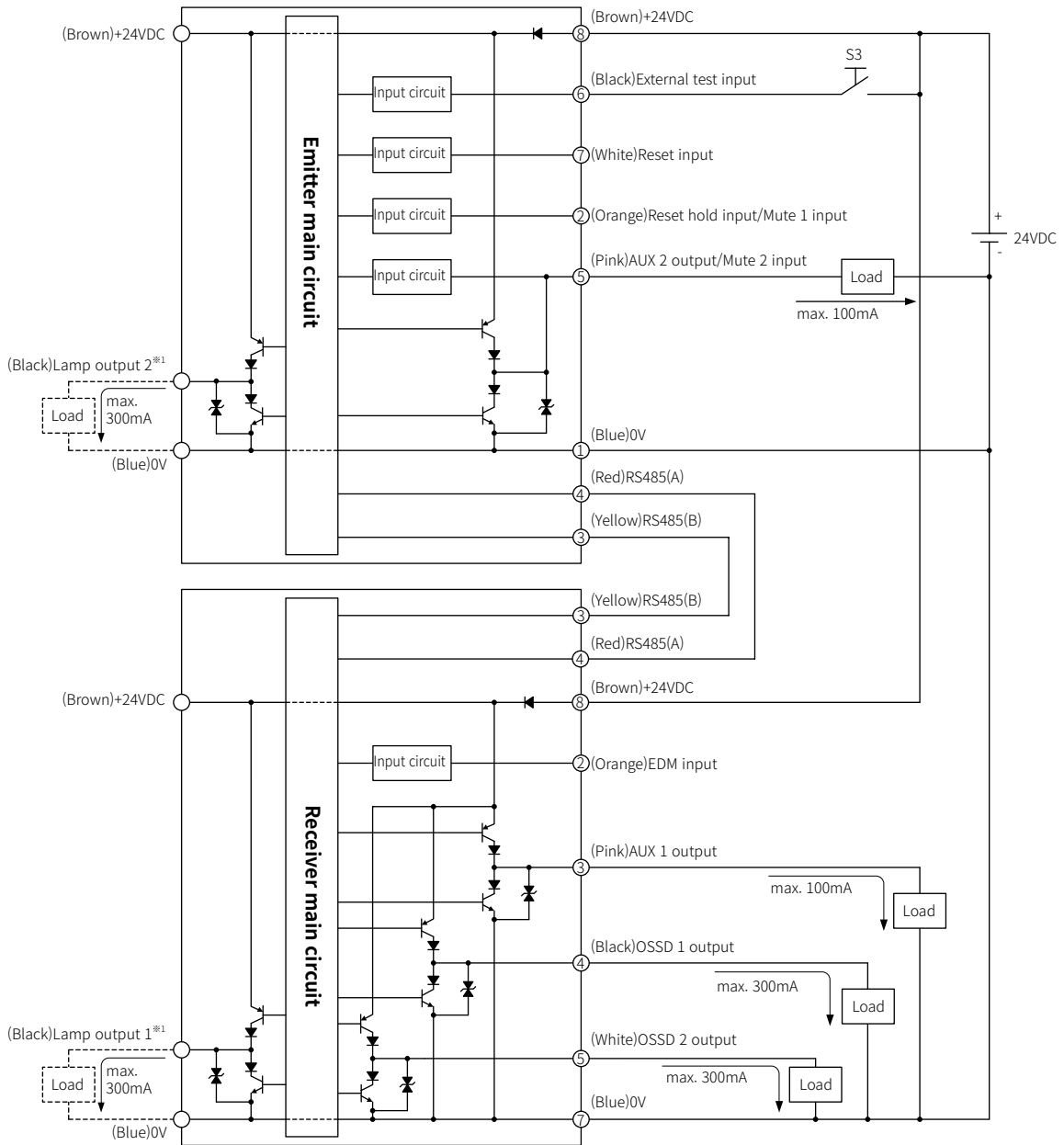

Note

- ※1: This wiring is used to activate the lamp output and the external indicator displays a status depending on the selected output mode.
- ※If there is a potential malfunction due to noise, combine a protection circuit to the input wiring, or connect a device with a protection circuit and apply the signal.

7.3 Wiring diagram for interlock and EDM

EDM	Interlock	Reset-hold	Muting
Enable	Enable (manual reset)	Disable	Disable

(1) NPN output

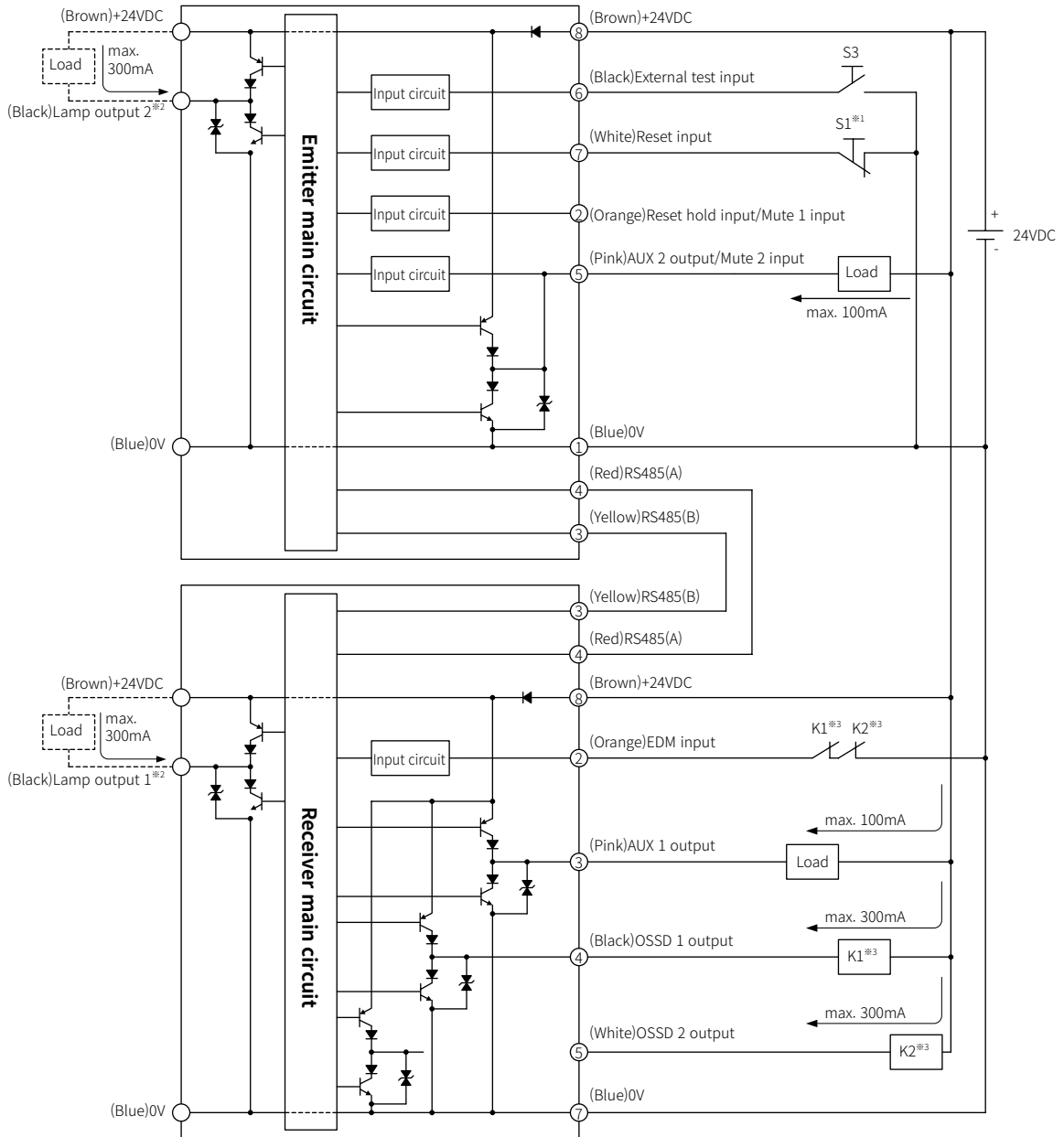

(2) PNP output

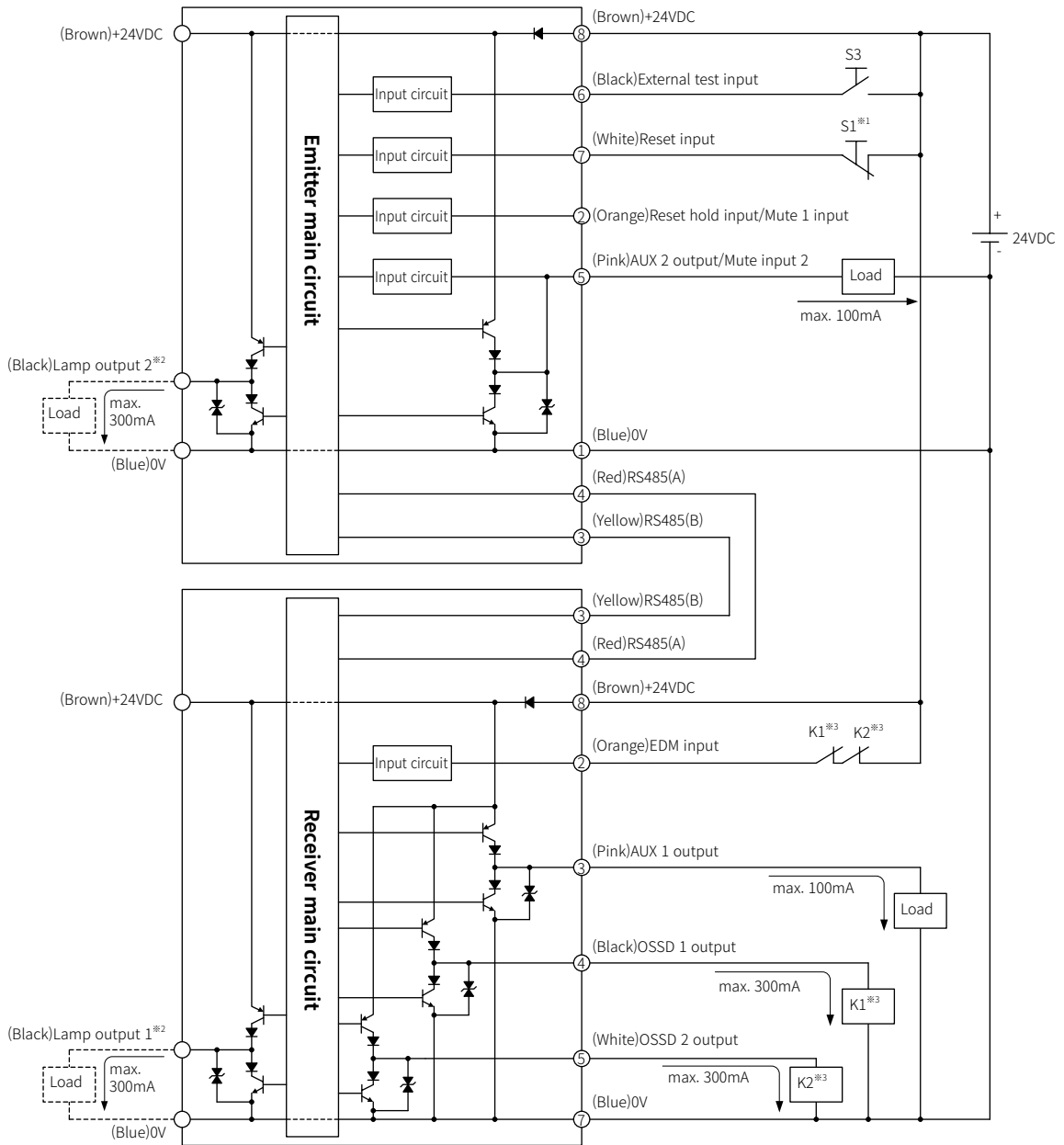

Note

- ※1: Reset switch to reset the interlock or lockout condition.
- ※2: This wiring is used to activate the lamp output and the external indicator displays a status depending on the selected output mode.
- ※3: K1 and K2 are external devices to use EDM function. Use external relay with force-guided contacts and magnet contactor for correct use.
- ※If there is a potential malfunction due to noise, combine a protection circuit to the input wiring, or connect a device with a protection circuit and apply the signal.

7.4 Wiring diagram for reset-hold

EDM	Interlock	Reset-hold	Muting
Disable	Enable (manual reset)	Enable	Disable

(1) NPN output

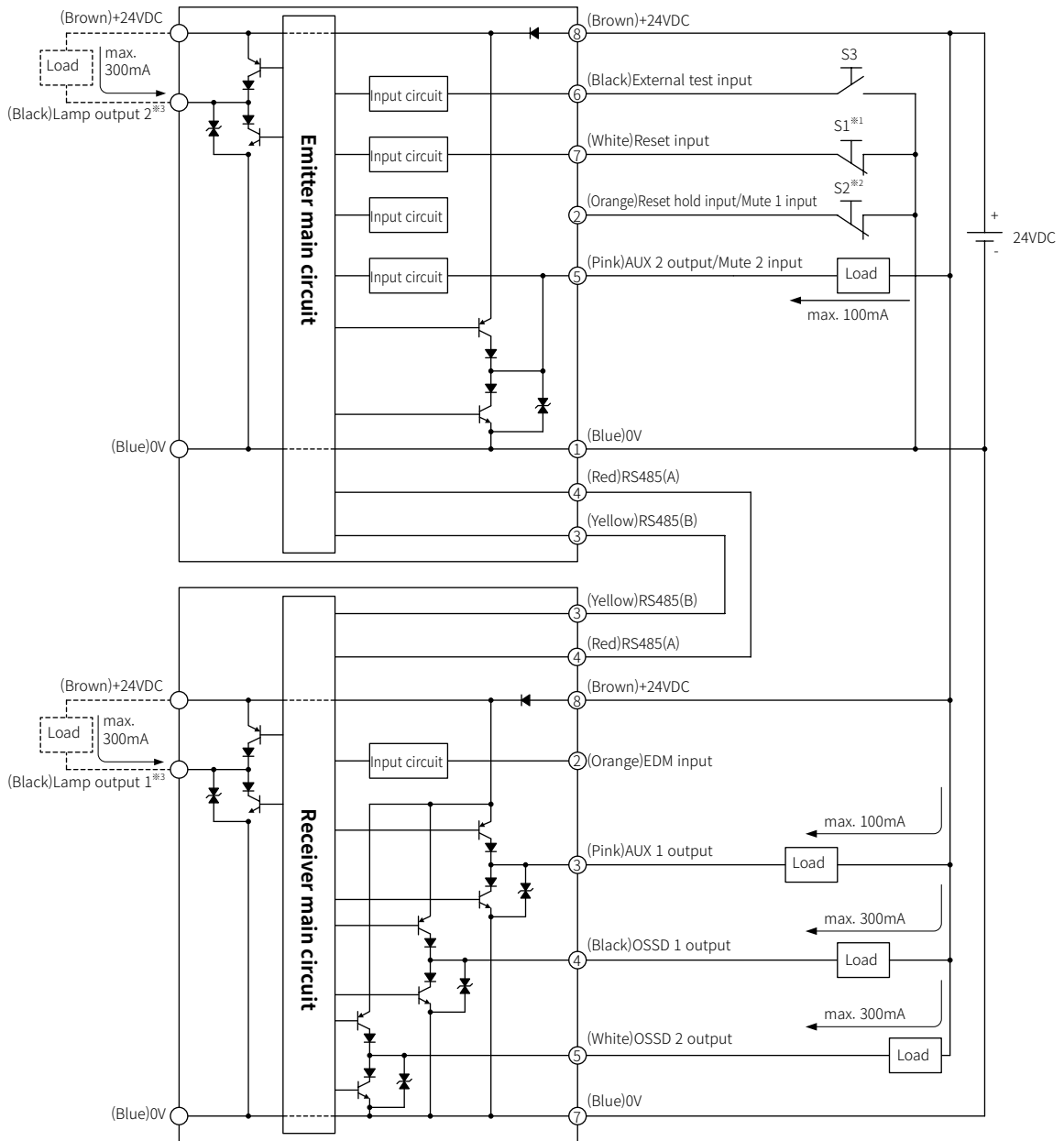

(2) PNP output

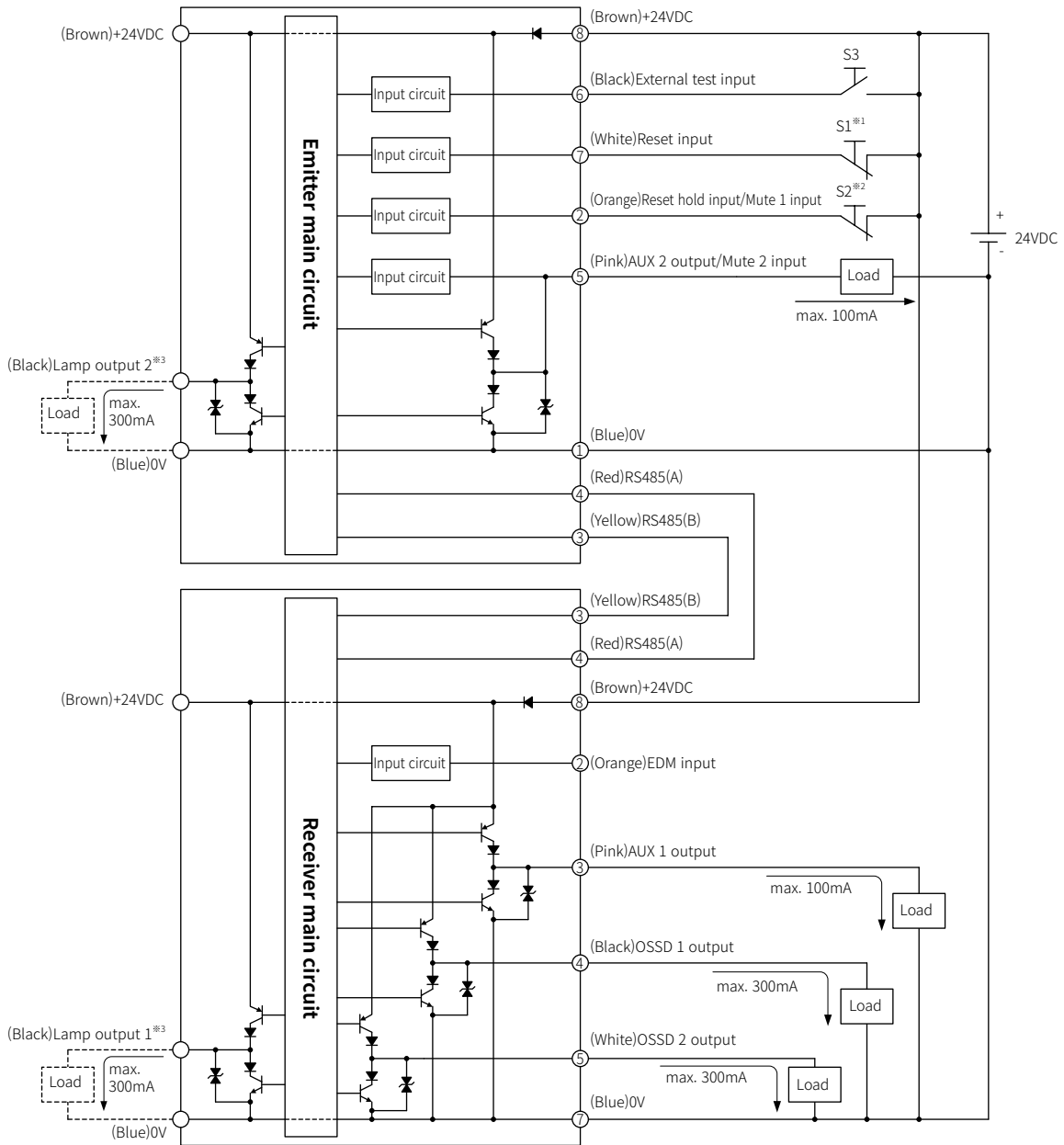

Note

- ※1: Reset switch to reset the interlock or lockout condition.
- ※2: Reset hold switch for reset hold input.
- ※3: This wiring is used to activate the lamp output and the external indicator displays a status depending on the selected output mode.
- ※If there is a potential malfunction due to noise, combine a protection circuit to the input wiring, or connect a device with a protection circuit and apply the signal.

7.5 Wiring diagram for muting

EDM	Interlock	Reset-hold	Muting
Disable	Disable (auto reset)	Disable	Enable

(1) NPN output

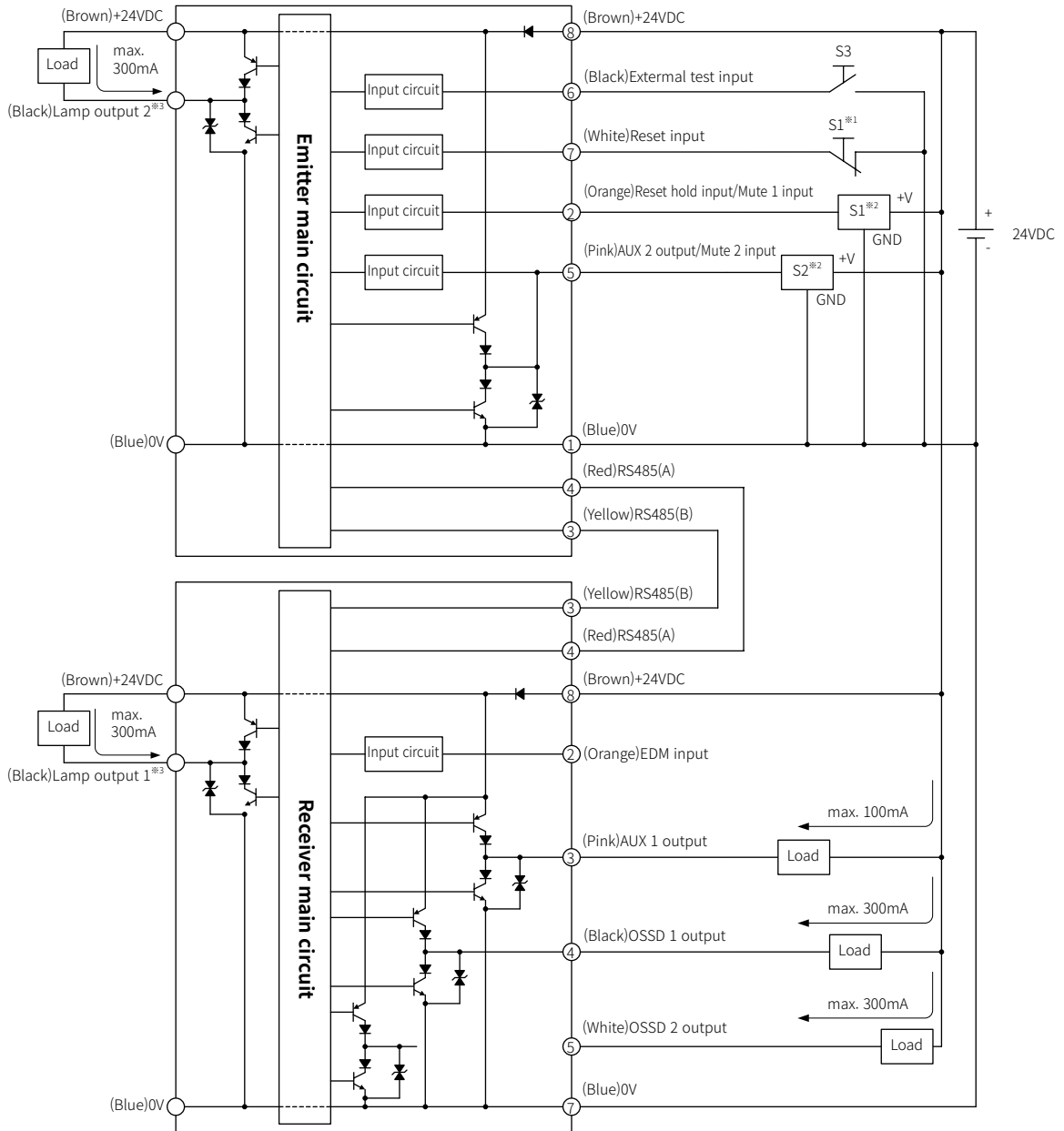

(2) PNP output

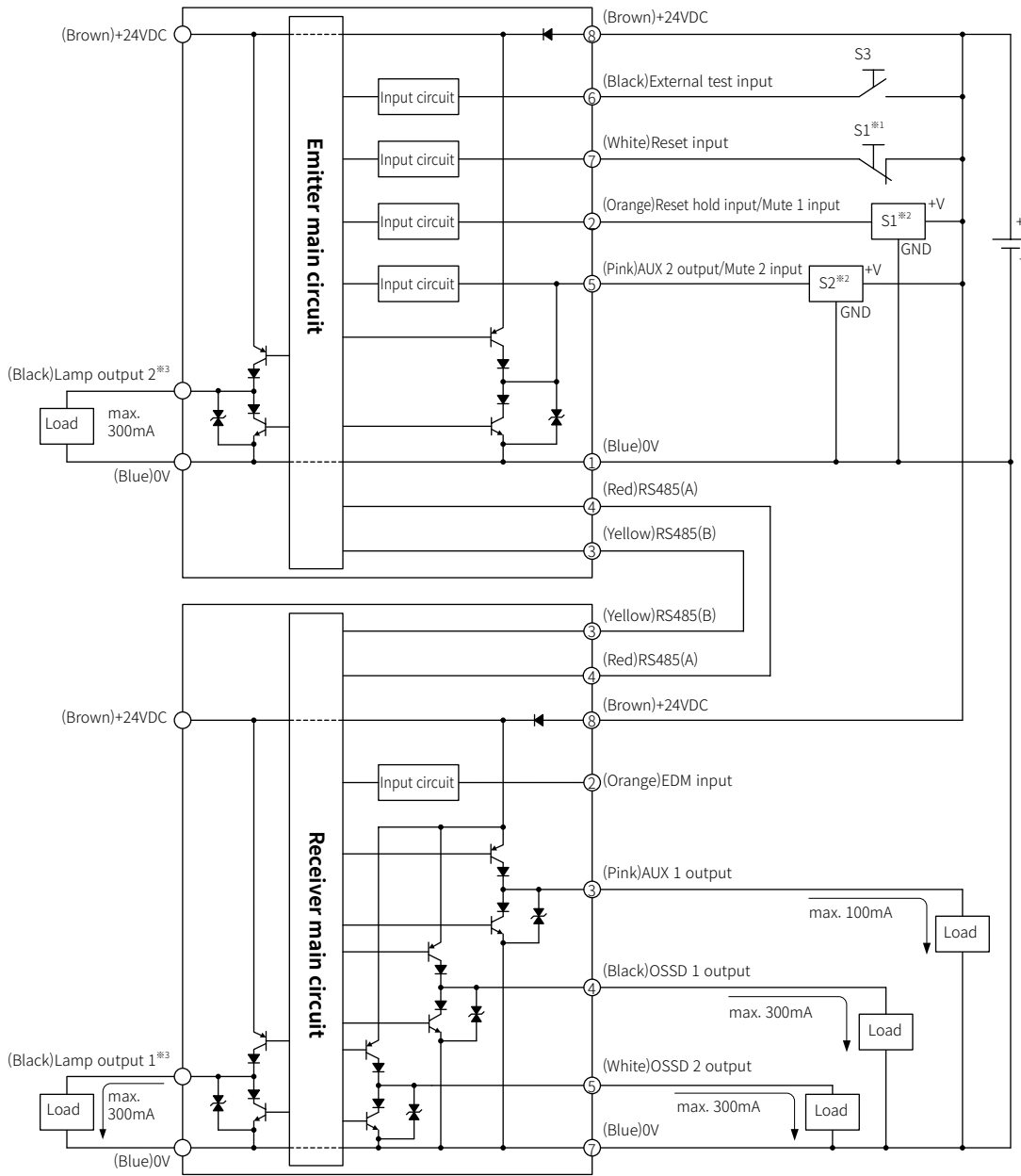

Note

- ※1: Reset switch for the override input.
- ※2: Use the muting sensors have the same output type (NPN, PNP) and 3-wire transistor output or N.O. contact. Use sensors that output is ON when detecting an object, and operate in Dark ON mode.
- ※3: This wiring is used to activate the lamp output and the external indicator displays a status depending on the selected output mode.
- ※If there is a potential malfunction due to noise, combine a protection circuit to the input wiring, or connect a device with a protection circuit and apply the signal.

8. Configuration software, atLightCurtain

atLightCurtain makes you can easily configure the functions of the light curtain and monitor them. SFLA, the high-performance and advanced, provides safety-related functions in muting, blanking and parameter menus. Using this, you can make more safe environments for the operators and more effective manufacturing process.

You can monitor your light curtain via atLightCurtain.

- Incident light level: Easy to adjust, maintain, and manage beams.
- Wiring and switch: Easy to check the I/O and switch status of the currently connected wiring.
- Error and warnings: Help to reduce the time required for troubleshooting by displaying error descriptions.

Administrator login mode allows only authorized person to modify settings so that you can protect and secure it.

8.1 System requirements

The system requirements for using atLightCurtain are as follows:

Item	Minimum specifications
System	IBM PC compatible computer with 1GHz or faster processor
Operating system	Microsoft Windows 7 or later
Memory	2GB or more
Hard disk	1GB free hard disk space
VGA	1024 X 760 or higher resolution display
Other	USB port

8.2 USB to Serial connection

You can use “USB to Serial” to communicate with your PC. Connect the light curtain and PC in the following order.

- Connect the converter cable (sold separately, EXT-SFL) to the PC connector on the bottom of the receiver.
- Connect the communication converter (sold separately, SCM-US) to the converter cable and connect to the USB port on the PC.

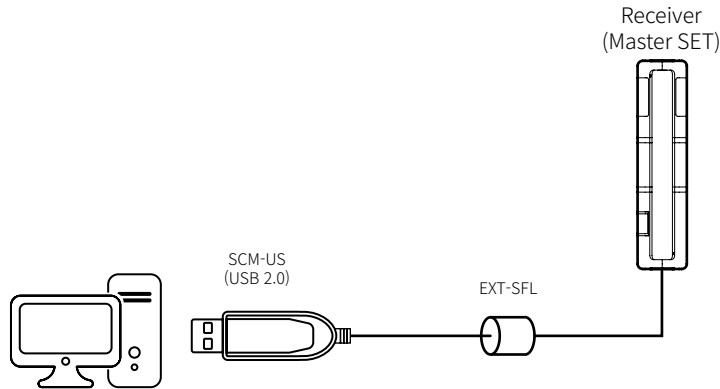

- ※When connecting to a PC in series connection, use the PC connection terminal at the master set of light curtain.
- ※When connecting to a PC, set the setting switch of emitter and receiver to the PC.
- ※When you change the detailed function of light curtain via atLightCurtain, be sure to conduct a sufficient risk assessment. The OSSD output can be switched to ON or OFF state regardless of actual light incident level.
- ※In case of the SFLA (advanced type), set the position 8 of setting switches on the emitter and receiver to ON for PC setting. The SFL (standard type) does not support the position 8 so that the settings of positions 1 to 7 are applied to the light curtain.

9. Installation

9.1 Installation conditions

Install the light curtain that complies with the following details.

- Part(s) of the human body passes through the detection zone to the hazards of the machine.
If the human can access a hazardous part of the machine without passing the detection zone, install an additional guard.
- Install an additional guard if part(s) of the human body access to hazards of the machine without passing through the detection zone.
- If an operator works in the hazardous part of the machine, be sure to install the light curtain to detect part(s) of the human body.

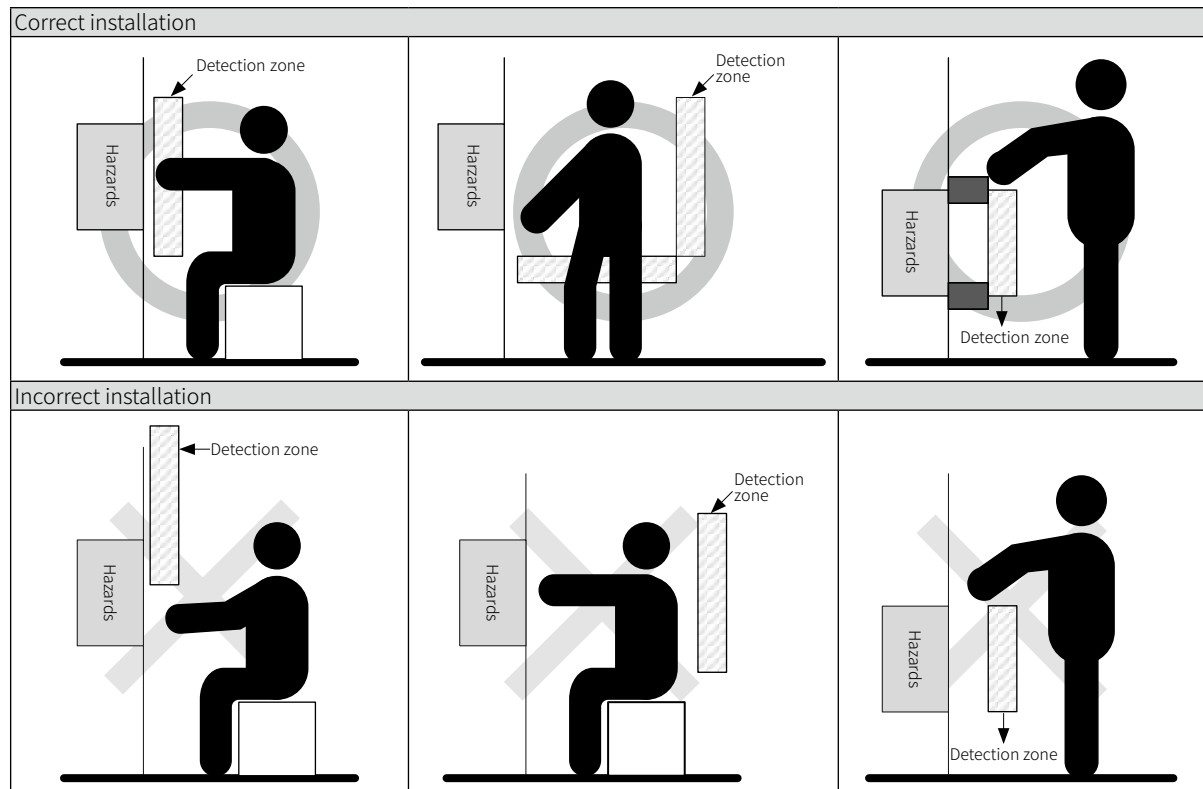

9.2 Safety distance

A safety distance is a minimum distance that a machine stops before the human or object approaches to hazards.

If you do not consider the safety distance when installing the light curtain, the machine may not stop before the human reaches hazards so that it may result in personal injury.

The safety distance calculation may differ from laws, regulations, and standards. Therefore, be sure to use the appropriate formula which abides by the rules of the country.

9.2.1 Safety distance according to ISO 13855 (EN ISO 13855, KS C 13855)

9.2.1.1 Basic formula

ISO 13855 defines the calculation of the safety distance using the formula below.

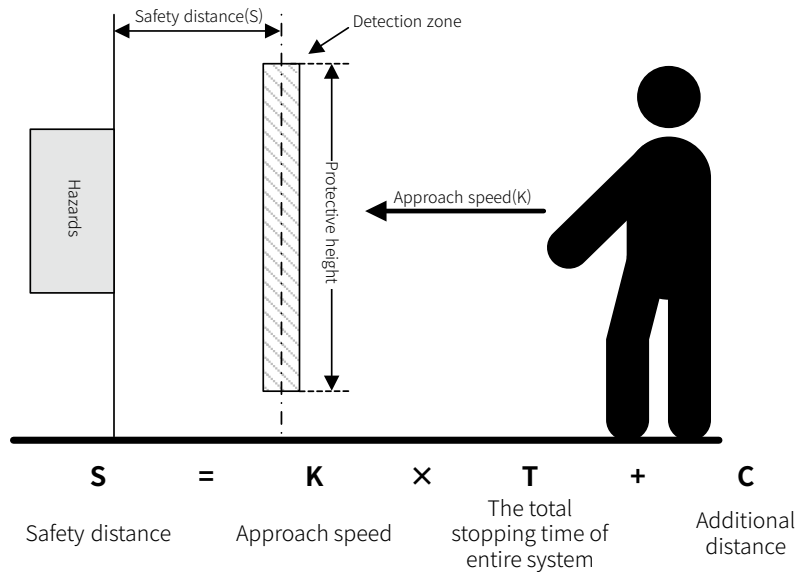

- Safety distance: minimum distance from the detection zone to the hazards
- K: The human approach speed in the detection zone
- T: The total stopping time of entire system, $T=t_1+t_2$
(t_1 : the product response time, t_2 : response time of the safety system)
- C: Additional distance calculated from the detection capability

9.2.1.2 Vertical access to the detection zone

If the detection zone is vertical with an approaching part(s) of the human body or object, calculate the safety distance using the following formula.

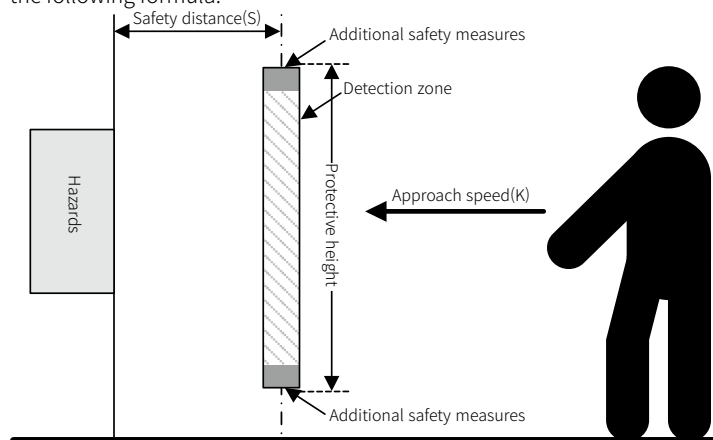

Note

※Part(s) of the human body or object could pass above and below the detection zone. To prevent this case, install the light curtain whose highest height of the detection zone is greater than 900 mm, and the lowest height of the detection zone is less than 300 mm.

※Even though all installation conditions are met, but it is expected to a potentially dangerous situation, be sure to take additional safety measures, such as installing a guard.

(1) When the detection capability is less than 40mm

If the detection capability of the safety system is 40 mm or less, use the formula below and install the light curtain at a location that has calculated safety distance or more.

If the safety distance is 500 mm or less by formula 1), apply the value.

However, the value is less than 100 mm, use 100 mm as the safety distance.

If the value resulting from formula 1) exceeds 500 mm, calculate again using formula 2).

However, the value is less than 500 mm, use 500 mm as the safety distance

$$\text{Formula 1) } S = K \times T + C = 2,000\text{mm/s} \times (t_1 + t_2) + 8 \times (d - 14\text{mm})$$

$$\text{Formula 2) } S = K \times T + C = 1,600\text{mm/s} \times (t_1 + t_2) + 8 \times (d - 14\text{mm})$$

Safety distance(S)	Minimum distance from the detection zone to the hazards
Approach speed(K)	Formula 1: 2,000mm/s, Formula 2: 1,600mm/s
The total stopping time of entire system(T)	$T = t_1 + t_2$ (t1: the product response time, t2: response time of the safety system)
Additional distance(C)	$C = 8 \times (d - 14\text{mm})$ ($C \geq 0$)
d	Detection capability



Ex.

How to calculate safety distance when; detection capability (d) is 20 mm, the product response time (t1) is 30 ms, the response time of the safety system (t2) is 200 ms. (The light curtains are installed vertically with the machine.)

- i. Calculate by formula 1)

Approach speed(K)	2,000mm/s
The total stopping time of entire system(T)	0.23sec
Additional distance(C)	48mm

- ii. $S = K \times T + C = 2,000\text{mm/s} \times (0.03\text{sec} + 0.2\text{sec}) + 8 \times (20\text{mm} - 14\text{mm}) = 508\text{mm}$
 iii. The calculated safety distance exceeds 500mm. Calculate again using formula 2).
 iv. $S = K \times T + C = 1,600\text{mm/s} \times (0.03\text{sec} + 0.2\text{sec}) + 8 \times (20\text{mm} - 14\text{mm}) = 416\text{mm}$
 v. Because the calculated safety distance is less than 500mm, install the safety distance as 500mm.

(2) When the detection capability is more than 40mm and less than 70mm.

If the detection capability is more than 40mm and less than 70mm, use formula 3) and install the light curtain at a location that has calculated safety distance or more.

Formula 3) is not designed for the hand detection, so be sure to use this calculation method for the safety system that the hand detection is unnecessary.

$$\text{Formula 3) } S = K \times T + C = 1,600\text{mm/s} \times (t_1 + t_2) + 850\text{mm}$$

Safety distance(S)	Minimum distance from the detection zone to a hazards
Approach speed(K)	1,600mm/s
The total stopping time of entire system(T)	$T = t_1 + t_2$ (t1: the product response time, t2: response time of the safety system)
Additional distance(C)	850mm (Standard arm length)
d	Detection capability



Ex.

How to calculate safety distance when; detection capability (d) is 50 mm, the product response time (t1) is 30 ms, the response time of the safety system (t2) is 60 ms. (The light curtains are installed vertically with the machine.)

- i. Calculate by formula 3)

Approach speed(K)	1,600mm/s
The total stopping time of entire system(T)	0.09sec
Additional distance(C)	850mm

- ii. $S = K \times T + C = 1,600\text{mm/s} \times (0.03\text{sec} + 0.06\text{sec}) + 850\text{mm} = 994\text{mm}$
 iii. Safety distance is 994mm.

9.2.1.3 Parallel access to the detection zone

If the detection zone is parallel with an approaching part(s) of the human body or object, calculate the safety distance using the following formula. Install the light curtain at a location that has calculated safety distance or more.

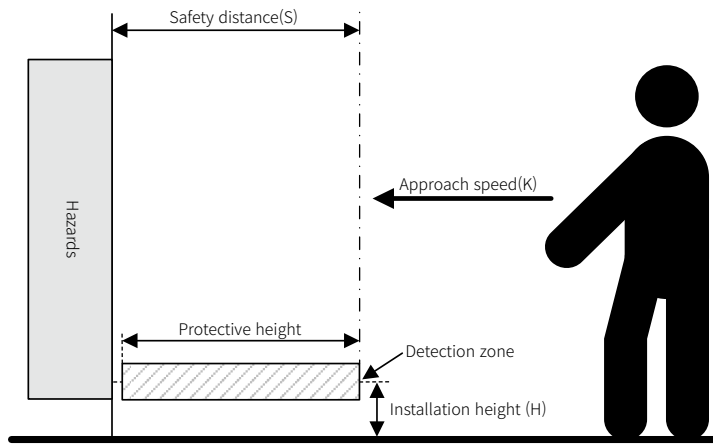

$$S = K \times T + C = 1,600\text{mm/s} \times (t_1 + t_2) + 1,200\text{mm} - (0.4 \times H)$$

Safety distance(S)	Minimum distance from the detection zone to the hazards
Approach speed(K)	1,600mm/s
The total stopping time of entire system(T)	T=t ₁ +t ₂ (t ₁ : the product response time, t ₂ : response time of the safety system)
Additional distance(C)	1,200-(0.4×H) (C≥850mm)
Installation height(H)	Height from bottom to the detection zone

※If the installation height is 300mm or more, part(s) of the human body or object could pass below the detection zone. To prevent this case, install a guard to take an additional safety measures. Maximum installation height is 1,000 mm.

※Calculate the minimum installation height using the following formula.
 $H = 15 \times (d - 50\text{mm})$ ($H \geq 0$)



Ex.

How to calculate safety distance when; detection capability (d) is 14 mm, the product response time (t₁) is 30 ms, the response time of the safety system (t₂) is 60 ms. (The installation height (H) of light curtains is 300 mm.)

i. Calculate by the formula

Approach speed(K)	1,600mm/s
The total stopping time of entire system(T)	0.09sec
Additional distance(C)	1080mm

ii. $S = K \times T + C = 1,600\text{mm/s} \times (0.03\text{sec} + 0.06\text{sec}) + 1,200\text{mm} - (0.4 \times 300\text{mm}) = 1,224\text{mm}$

iii. Safety distance is 1,224mm.

9.3 How to install and adjust your light curtain

- ① Place the bracket in the position where the light curtain will be installed and install the emitter and the receiver face to each other.
 - ② Power on the light curtain.
 - ③ Adjust the top and bottom beam of the light curtain to meet the centerline. If the top and bottom beams are aligned, the indicator lights up. You can monitor the light incident level via atLightCurtain.
 - ④ If all beams are clear, tighten the bracket screws to fix it.
- ※If the beams are unstable because the beams are not completely aligned, the top beam and bottom beam indicators flash every 1 second. If the beams are blocked, the indicators light off.
- ※Do not install the light curtain in a place that is exposed directly to fluorescent lamps operating with a quick start or high frequency.



Warning

Make sure that a qualified personnel must carry out the installation and settings of light curtain, and its combination with the machine control system. If it performed by a person other than responsible person for use, it may result in personal injury due to undetected human body.

9.4 Installation for mutual interference prevention

When connecting two or more light curtains to extend the detection zone, it may result in mutual interference. Refer to the following chapters to prevent mutual interference.

9.4.1 When using a series connection

You can connect light curtains up to 4 sets using the series connection cable. The extended light curtains work to prevent interference by controlling light emission. For more information, see "6.1 Series connection"

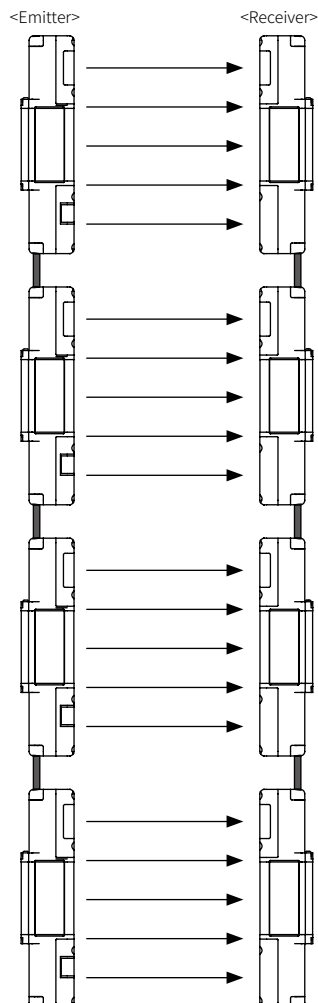

9.4.2 When using one set of the light curtain

(1) Install the light shield plate between the light curtains

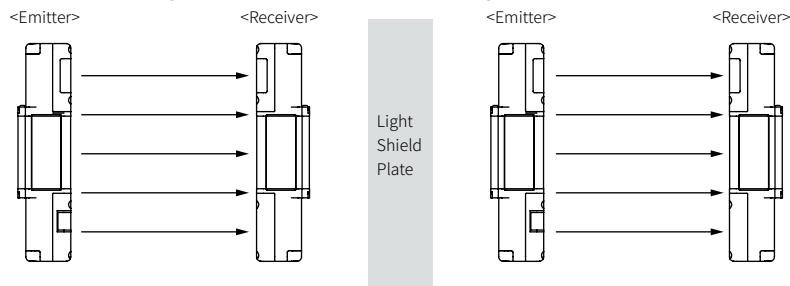

(2) Reverse the direction of the emitter

- When placing the light curtains in parallel

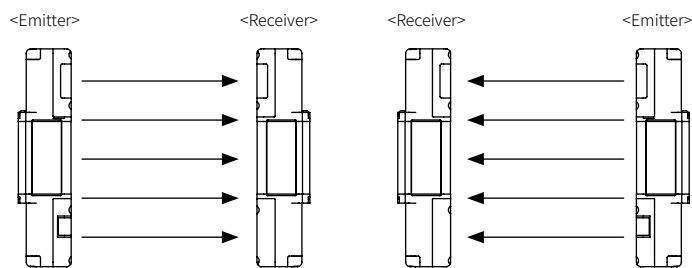

- When placing the light curtain in vertical

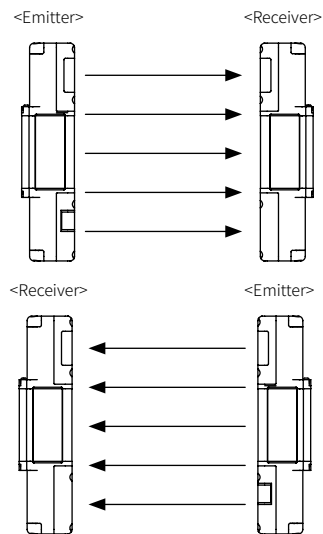

- When placing the light curtains in parallel

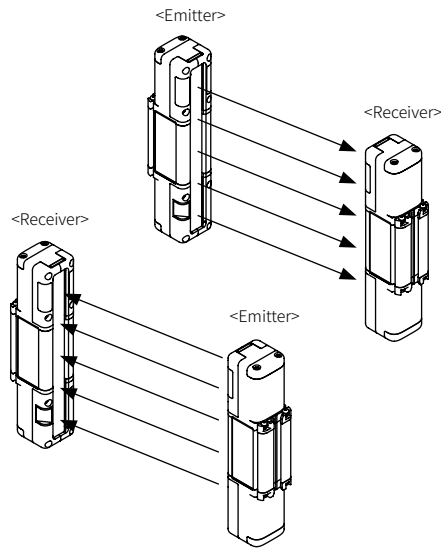

(3) Install the light curtains with space between them for preventing mutual interference

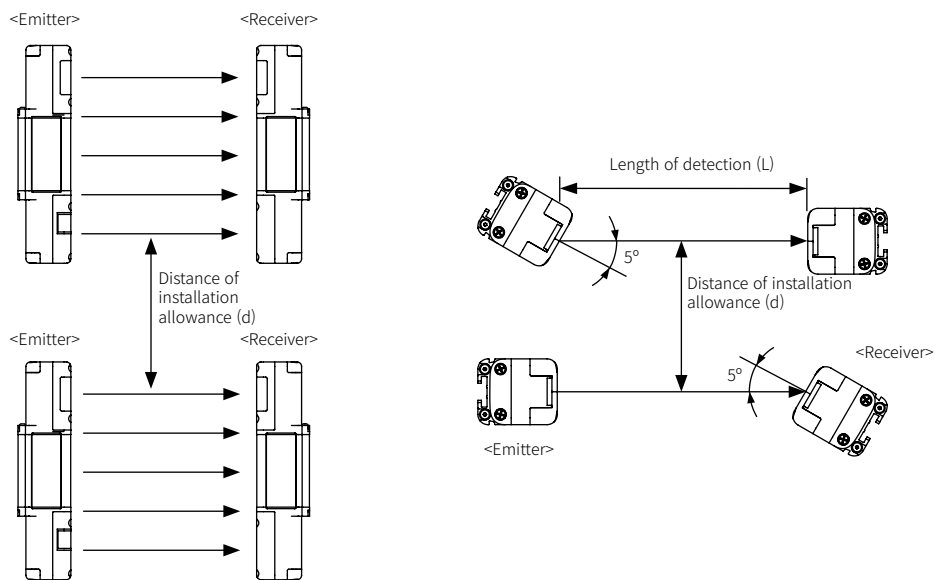

Length of detection(L)	Distance of installation allowance (d)
0.2-3m	0.131m
Min. 3m	$L/2 \times \tan 5^\circ \approx L \times 0.0437m$

※It may differ depending on the environmental condition.

※Do not install the light curtain in a place that is exposed directly to fluorescent lamps operating with a quick start or high frequency.

(4) Change the frequency of light curtain

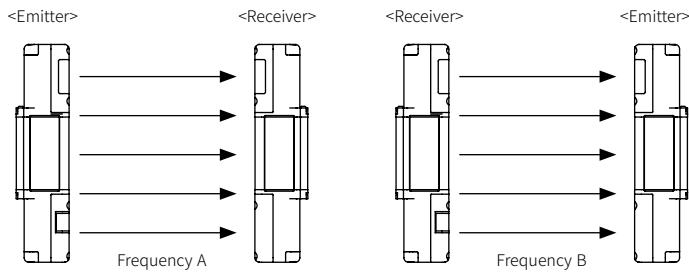

Select the frequency A or B via the setting switch or at LightCurtain.
 The response time may differ from the specifications depending on the selected frequency.
 ※For more information in the frequency change, see "4.5 Mutual interference prevention"

9.4.3 About installation of a reflective surface

If the reflectance of wall or floor is high (metal and mirror, etc.) around the installation environment, the light curtain may not operate properly by the reflected light.

Before installation, be sure to check normal operation with the detection object and install the reflective surface at a certain distance.

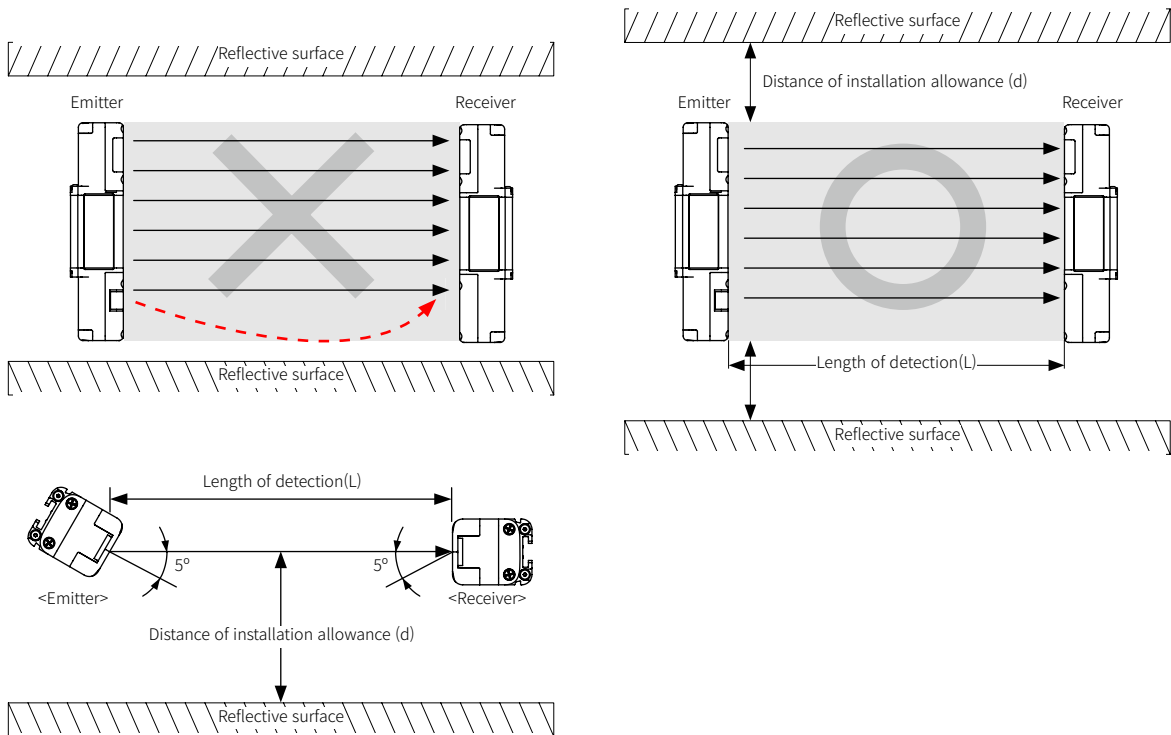

Length of detection(L)	Distance of installation allowance (d)
0.2-3m	0.131m
Min. 3m	$L/2 \times \tan 5^\circ \approx L \times 0.0437m$

9.5 Mount brackets

9.5.1 Top/Bottom adjustable bracket (BK-SFL-TBA)

Insert the square nuts into the product guide rails and install the brackets using the enclosed bolts. Adjust the angle of rotation first, and tighten the anti-rotation bolts. Tighten the anti-rotation bolts and fixing bolts with a torque of 0.98 N m.

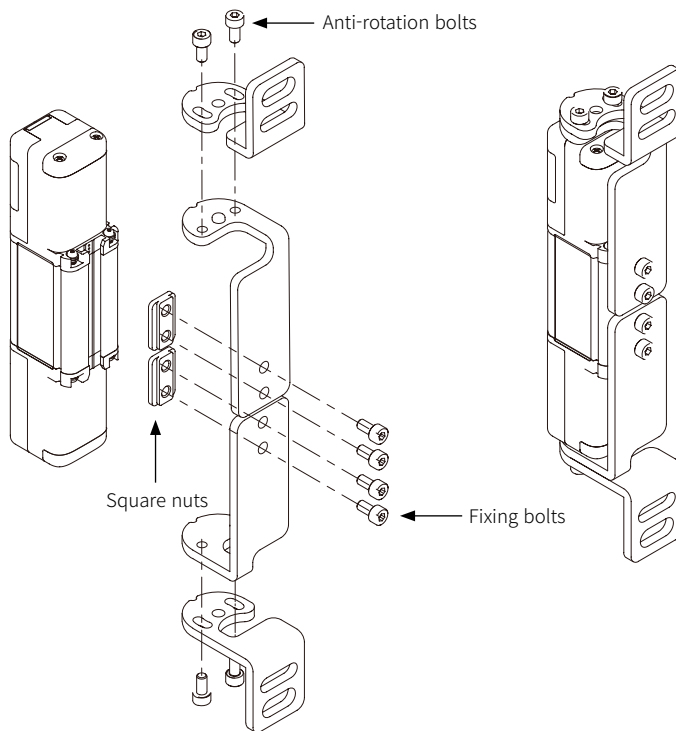

9.5.2 Top/Bottom bracket (BK-SFL-TBF)

Insert the square nuts into the product guide rails and install the brackets using the enclosed bolts. Tighten the fixing bolts with a torque of 0.98 N m.

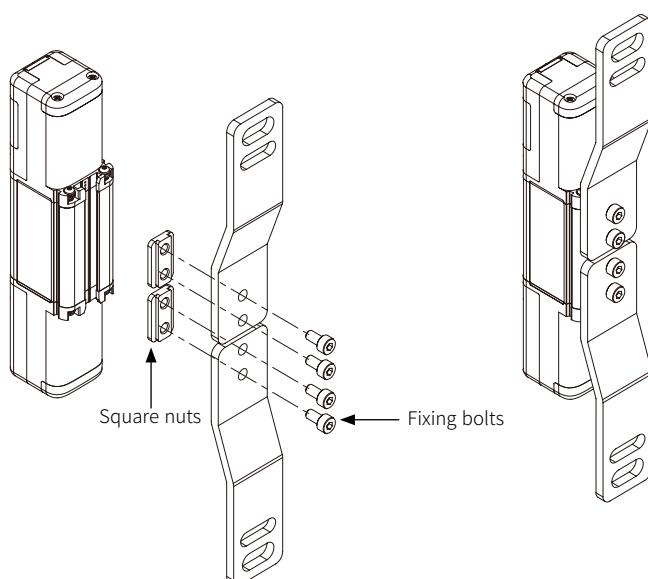

9.5.3 Side adjustable bracket (BK-SFL-SA)

Insert the light curtain to the bracket and tighten the enclosed product fixing bolts to fix. Adjust the angle of rotation first, and tighten the anti-rotation bolts.

Tighten the anti-rotation bolts and product fixing bolts with a torque of 0.98 N m.

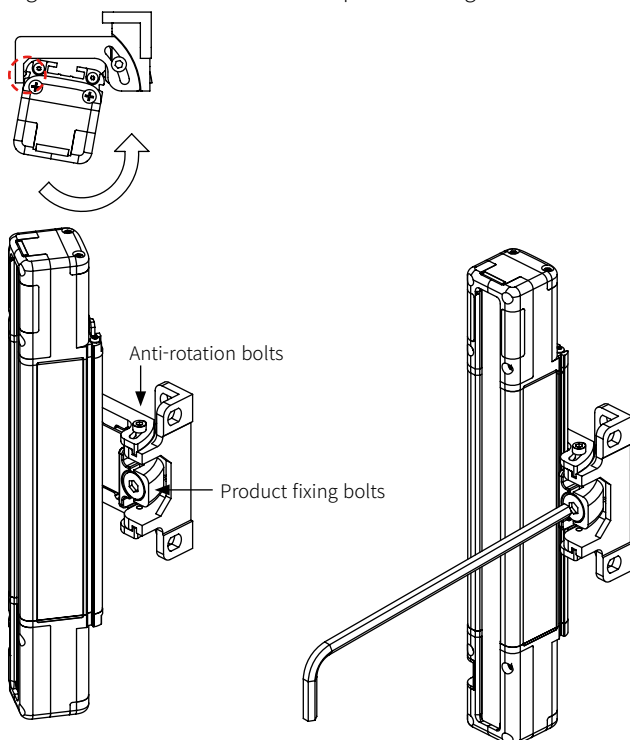

9.5.4 Side bracket (BK-SFL-SF)

Insert the light curtain to the bracket and tighten the enclosed product fixing bolts to fix. Tighten the product fixing bolts with a torque of 0.98 N m.

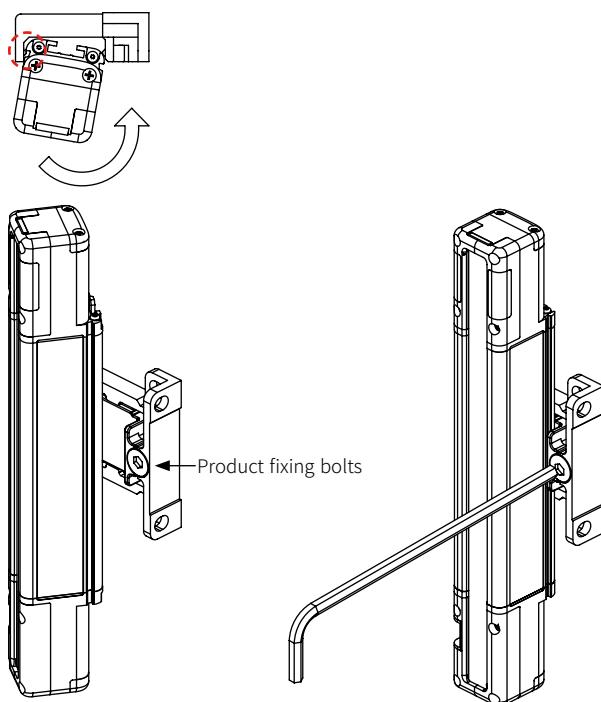

9.5.5 Cautions when using the brackets

The type and number of brackets differ depending on the length of the light curtain. Refer to the table below to install the brackets.

Brackets	Length	Max. 1m	Min. 1m
	Top/Bottom adjustable bracket		2
Top/Bottom bracket			
Side adjustable bracket		2	3
Side bracket			

<Max. 1 m>

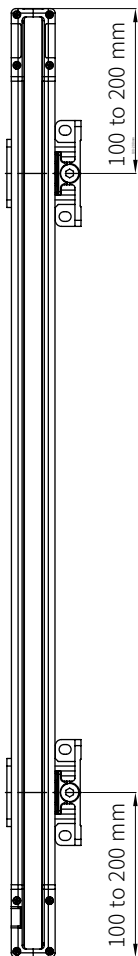

<Min. 1 m>

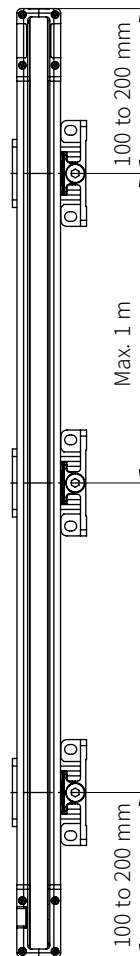

- If the length of the light curtain is less than 1 m, use two brackets.
- If the length of the light curtain is more than 1 m, use the side adjustable brackets and the side brackets. The top/bottom adjustable brackets and the top/bottom brackets cannot be used.

10. Check and maintenance

10.1 Check installation conditions

No.	Checklist	Check
1	Installed that the machine or additional safety measures (e.g., extra guards) do not cover the detection zone.	
2	Accessible to hazardous zone or source of the machine only by passing through the detection zone.	
3	Available to detect parts of the body when the operator works in hazardous zone or source of the machine.	
4	The distance from hazardous zone or source of the machine to the installed location of light curtain is equal to, or greater than the calculated safety distance. ※ Safety distance: ()mm / Actual distance: ()mm	
5	If lustered objects or reflective surfaces are around, the light curtain is installed at a distance over the allowable installation distance.	
6	Installed in a place without the influence of inverter disturbance light (e.g., a fluorescent lamp).	
7	Installed in a place that no material causes deformation in a front window, such as corrosion or ignition.	
8	In use of the interlock function, the reset switch is installed in a position where the entire hazardous zone is visible and cannot be used in the hazardous zone.	
9	In use of the reset hold function, the reset hold switch is installed in a position that cannot be used in the hazardous zone.	
10	The installed emitter/receiver in a single or series connection matches the same specification (function, detection capability, number of optical axes).	
11	In case of the brackets, it is secured to prevent separation during use.	
12	No scratches or damages on the front window of the emitter/receiver.	
13	In use of the muting function, the muting sensors consist of two separate devices.	
14	In use of the muting function, the muting sensor meets the specific conditions to start muting.	
15	In use of the override function, the override starts when the specific conditions are met.	
16	In use of the muting and override functions, install the indicators with any forms (e.g., alarm lamp) where it can be seen from all sites.	
17	In use of the fixed blanking function, it is set to prevent the operator from entering the blanking zone.	
18	In use of the floating blanking or reduced resolution function, the installed light curtain has a distance that equal to or greater than a safety distance calculated by the changed detection capability (diameter). ※ Safety distance: ()mm / Actual distance: ()mm	

10.2 Check wiring connection

No.	Checklist	Check
1	The power supply used for the product and safety-related devices (e.g., muting sensors) is 24VDC, and it meets the rated specifications and not connected to other devices or equipment.	
2	When connecting power supply, the polarity is not connected in reverse.	
3	The appearance of the wires connected to the product is not damaged, such as cracks, breakage of the outer shell. And there are no sources for damage around the wiring.	
4	In case of connecting more than two products, it is configured to use dedicated series connection cable and mutual interference prevention.	
5	In case of the series connection for more than two products, use dedicated series connection cable, and it is configured not to be extended or arbitrarily connected.	
6	The wiring is suitable for each application and is configured not to be connected upper side of the product (e.g., wiring for the series connection cable and lamp output cable) and the lower side of the product (e.g., the power I/O cable) in reverse.	
7	The wiring and end cap connected to the product are firmly secured to prevent separation during use.	
8	The product is connected to the safety-related part of the control system using two OSSD control outputs and configures the safety system.	
9	In case of the product is set to PNP output, two OSSD wires are not shorted to +24V.	
10	In case of the product is set to PNP output, the load connected to two OSSD wires is connected between the OSSD wire and 0V.	
11	In case of the product is set to NPN output, two OSSD wires are not shorted to 0V.	
12	In case of the product is set to NPN output, the load connected to two OSSD wires is connected between the OSSD wire and +24V.	
13	In case of the auxiliary output (AUX 1/2, Lamp 1/2), it is configured to prevent the connection to the safety-related part of the control system.	

10.3 Safety-related system-check when the operation stops

No.	Checklist	Check
1	Use the cylindrical opaque object (test piece) with the same diameter as the detection capability to verify the operation when the product stops.	
2	In use of the floating blanking or reduced resolution function, use test piece with the same diameter as the detection capability based on the tolerance to verify the operation when the product stops.	
3	The test piece can be detected at any position in the detection zone. The OSSD indicator lights red, and the two OSSD control outputs are turned OFF and maintain the status. ^{*1}	
4	In case of the test piece is not within the detection zone, the OSSD indicator lights green, and the two OSSD control outputs are turned ON and maintain the status.	
5	In use of the external test function, the OSSD indicator lights red when the input is applied, and the two OSSD control outputs are turned OFF and maintain the status.	
6	In use of the EDM function, short the EDM input and then put the test piece in the detection zone (NPN output: 24VDC, PNP output: 0V). The light curtain will turn into lockout condition. At this time, the OSSD indicator lights red, and the two OSSD control outputs are turned OFF and maintain the status.	
7	In use of the start interlock function, the OSSD indicator remains red when the product is turned on with no test piece in the detection zone. The two OSSD control outputs are turned OFF and maintain the status. After that, the reset input is applied, and the OSSD indicator lights green, and the two OSSD control outputs are switched to ON and maintain the status.	
8	In use of the restart interlock function, the OSSD indicator remains red even though the test piece is inserted and removed while the OSSD is ON state, and the two OSSD control outputs maintain OFF state. After that, the reset input is applied, and the OSSD indicator lights green, and the two OSSD control outputs are switched to ON and maintain the status.	
9	In use of the muting function, the muting sensor operates in normal state.	
10	In use of the muting function, the muting starts when the specific conditions are met. At this time, when the test piece enters into the detection zone, the OSSD indicator maintains green, and the two OSSD control outputs remain ON state.	
11	In use of the muting and override function, the indicators (e.g., alarm lamp) installed where it can be seen from all sites are in normal operation.	
12	In use of the fixed blanking function, there is a fixed object in the blanking zone.	

*1: When inspecting the product using the test piece, move it in the order below.
 The test piece should be vertical to the detection zone with a speed of less than 1.6 m/s.

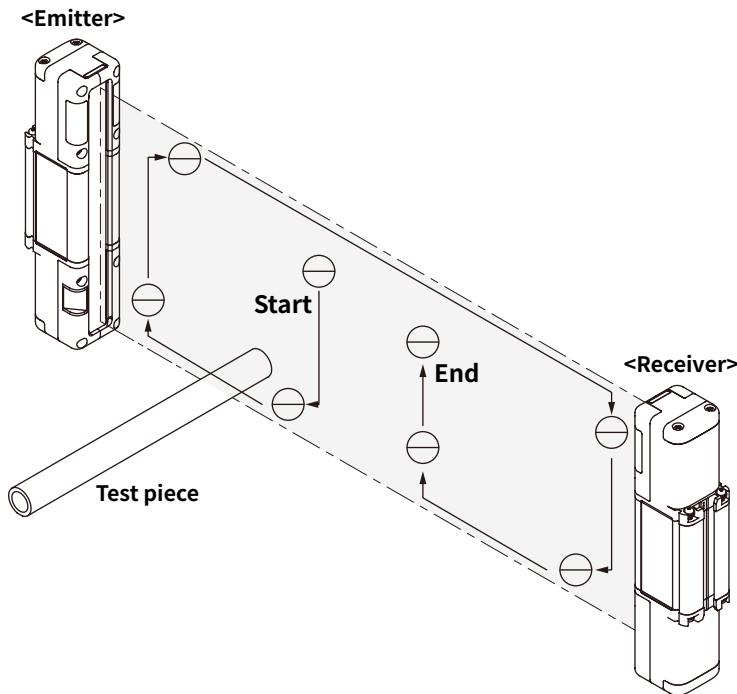

10.4 Safety-related system-check in operation

No.	Checklist	Check
1	Inspect without operator in the hazardous zone or near the source of hazard.	
2	When the test piece enters the detection zone (in front of the emitter/receiver, between the emitter and the receiver) while the machine is running, the safety system immediately stops.	
3	While the test piece remains the detection zone, the safety system keeps the stop state.	
4	In case of the power shut down, the safety system stops and maintains it.	
5	The actual response time of the machine (the time taken for the hazardous source to stop) is less than the calculated time. ※ Calculated machine response time: ()ms / Actual machine response time: ()ms	

10.5 Daily inspection

No.	Checklist	Check
1	Accessible to hazardous zone or source of the machine only by passing through the detection zone.	
2	Available to detect parts of the body when the operator works in hazardous zone or source of the machine.	
3	The distance from hazardous zone or source of the machine to the installed location of SFL(A) is equal to, or greater than the calculated safety distance. ※ Safety distance: ()mm / Actual distance: ()mm	
4	In use of the floating blanking or reduced resolution function, the installed light curtain has a distance that equal to or greater than a safety distance calculated by the changed detection capability (diameter). ※ Safety distance: ()mm / Actual distance: ()mm	
5	In use of the fixed blanking function, it is set to prevent the operator from entering the blanking zone.	
6	No scratches or damages on the front window of the emitter/receiver.	
7	In use of the muting function, the detection window of the connected muting sensor is free from scratches or damages.	
8	In use of the muting function, the connected muting sensor operates in normal state.	
9	In use of the muting function, the installation of the connected muting sensor is unchanged and maintained.	
10	The appearance of the wires connected to the product is not damaged, such as cracks, breakage of the outer shell. And there are no sources for damage around the wiring.	
11	In case of the brackets, it is secured to prevent separation during use.	
12	The wiring and end cap connected to the product are firmly secured to prevent separation during use.	
13	"Safety-related system - check when the operation stops" is performed normally.	
14	"Safety-related system - check in operation" is performed normally.	

10.6 Regular inspection

No.	Checklist	Check
1	The distance from hazardous zone or source of the machine to the installed location of SFL(A) is equal to, or greater than the calculated safety distance. ※ Safety distance: ()mm / Actual distance: ()mm	
2	In use of the floating blanking or reduced resolution function, the installed light curtain has a distance that equal to or greater than a safety distance calculated by the changed detection capability (diameter). ※ Safety distance: ()mm / Actual distance: ()mm	
3	In use of the fixed blanking function, it is set to prevent the operator from entering the blanking zone.	
4	Installed in a place without the influence of inverter disturbance light (e.g., a fluorescent lamp).	
5	No scratches or damages on the front window of the emitter/receiver.	
6	The external structure of the installed emitter and receiver is free from scratches or damages.	
7	In use of the muting function, the detection window of the connected muting sensor is free from scratches or damages.	
8	In use of the muting function, the connected muting sensor operates in normal state.	
9	In use of the muting function, the installation of the connected muting sensor is unchanged and maintained.	
10	In case of the brackets, it is secured to prevent separation during use.	
11	The wiring and end cap connected to the product are firmly secured to prevent separation during use.	
12	The appearance of the wires connected to the product is not damaged, such as cracks, breakage of the outer shell. And there are no sources for damage around the wiring.	
13	I/O wiring of the product is firmly secured to prevent separation from each device.	
14	The beams are aligned correctly.	

11. Troubleshooting

- Lockout condition
 - : If an error occurs during power-on or self-test, the safety-related function is deactivated and the OSSD output is switched to the OFF state within the response time. The status indicator displays the status of the light curtain. The 7-segment display shows the error code.
- Warning condition
 - : If the light curtains operate in an unstable state, only some parts of safety-related functions activate normally. The OSSD output maintains ON state, but it depends on the light incident. The status indicator displays the status of the light curtain. The 7-segment display shows the warning code.
 - ※In case of blanking warning, the OSSD output is switched to OFF state. For more information, see "5.6 Blanking"

11.1 Error code (Lockout condition)

It switches between level 1 and level 2.

Indicator		Error Name	Cause	Check and Measures
Level 1	Level 2			
E	-	RS485 Communication Error (Communication error between Emitter and Receiver)	Communication line or other wiring is broken or short-circuited.	Check the power I/O cable and series connection cable.
			The communication line does not meet the specifications.	Use wires that meet the specifications.
			Communication error occurred due to noise.	Check the environmental conditions around the communication line and remove the noise source.
			Contact failure occurred at the connector of power I/O cable or that of series connection cable.	Check the power I/O cable and series connection cable.
E → 0	1-3	Emitter MCU Error	Error is detected at the internal MCU of the emitter.	Replace the emitter.
	4-7	Receiver MCU Error	Error is detected at the internal MCU of the receiver.	Replace the receiver.
E → 1	1-2	Power Supply Error	Power voltage is out of the rated range.	Connect to the rated power voltage (24VDC ± 20%). Use the dedicated power supply. Do not use the power with other devices.
E → 2	1-2	End Cap Error	The end cap is assembled incorrectly or is not connected.	Check the connection of the end cap.
		Incorrect series connection	The series connection is incorrect.	Check the connection of the series connection cable.
E → 3	1-3	Wiring Error in OSSD Outputs	The wire of OSSD 1 or 2 is broken or short-circuited.	Check whether the wiring connection of OSSD 1 or 2 output is correct.
			The OSSD 1 or 2 output is affected by external noise.	Check whether an external noise is flowing through the wiring of the OSSD 1 or 2 output and remove the noise source.
			Too much current flows into the OSSD 1 or 2 output.	Check the load connected to the wiring of OSSD 1 or 2 output meets the rated range.
			The output of OSSD 1 or 2 is invalid.	Check whether the wires of OSSD 1 or 2 output are correctly connected or replace the receiver.
	4-5	Failure in OSSD Internal Circuit	The internal circuit of the OSSD 1 or 2 output is broken.	Replace the receiver
E → 4	-	Setting Switch Error	The positions of the setting switch on the emitter and the receiver are not the same.	Check whether the settings of setting switch on the connected emitter and receiver are the same. In case of the series connection, check whether the settings of setting switch of the each master set are the same.
			The positions of the setting switch on the emitter and the receiver are changed during operation.	Check whether the settings of setting switch are the same as the settings before the operation. In the series connection, check whether the settings of setting switch on the master set are the same as before the operation.

Indicator		Error Name	Cause	Check and Measures
Level 1	Level 2			
E → 5	1	Error in Series Connection	The series connection is incorrect.	Check the series connection cable.
	2		The series connection is configured with the combination of SFL and SFLA.	Check whether the series connection is configured with combination of SFL and SFLA.
	3		The series connection is configured with the combination of the emitter and the receiver.	In the series connection, check whether the connection is configured with combination of the emitter and receiver.
	4		The configuration of series connection exceeds the rated range.	In case of the series connection, check whether the total number of connected light curtain (SET) is within the rated range. In case of the series connection, check whether the total number of optical axes of the connected light curtains is within the rated range.
E → 6	1-4	Emitter Error	The internal circuit of the emitter is broken or the internal setting is invalid.	Replace the emitter.
E → 7	1-5	Receiver Error	The internal circuit of the receiver is broken or the internal setting is invalid.	Replace the receiver
E → 8	1	Lamp 1 Error	The wire of lamp 1 output is broken or short circuited.	Check whether the wiring of lamp 1 output is correct.
			Too much current flows into the lamp 1 output.	Check whether the load that is connected to the lamp 1 output meets the rated range.
2	Lamp 2 Error	The wire of lamp 2 output is broken or short circuited.	Check whether the wiring of lamp 2 output is correct.	
		Too much current flows into the lamp 2 output.	Check whether the load that is connected to the lamp 2 output meets the rated range.	
E → 9	1	EDM Error	The EDM input is not normally applied.	Check the external devices (e.g. Relay).
			The contact of the EDM input terminal is invalid.	Check the connection of external devices (e.g. Relay).
			The EDM input is not applied within the time limit.	Check the response time of external devices (e.g. Relay).
	2	Blanking Error	The beams of the fixed blanking zone are clear. (except for the tolerance)	Check whether there is a detection object in the fixed blanking zone.
			The number of blocked beams is less than a certain level. (The number of beams of the floating blanking - tolerance)	Check whether there is a detection object in the floating blanking zone.
3	Setting Information Error	The muting and the reset-hold are activated at the same time.	On the setting switch of the connected emitter and receiver, check whether the muting and the reset-hold are activated at the same time.	
E	-	Internal System Error	An error occurs in the internal system of light curtains.	Replace the emitter or the receiver.

※For more information on the error and warning code when using the atLightCurtain, see “atLightCurtain User Manual.”

11.2 Warning code

It switches between level 1 and level 2.

Indicator		Error Name	Cause	Check and Measures
Level 1	Level 2			
$A \rightarrow 1$	1-2	Power Voltage Error	Power voltage is in unstable condition.	Connect to the rated power voltage (24VDC \pm 20%). Use the dedicated power supply. Do not use the power with other devices.
$A \rightarrow 2$	-	Disturbance Light Interference	Receiver is affected by interference of light.	Remove a light source and object around the receiver, which causes a disturbance.
$A \rightarrow 3$	-	Blanking Error	The beams of the fixed blanking zone are clear(except for the tolerance).	Check whether there is a detection object in the fixed blanking zone.
			The number of blocked beams is less than a certain level. (The number of beams of the floating blanking - tolerance)	Check whether there is a detection object in the floating blanking zone.
$A \rightarrow 4$	-	PC Communication Error	The setting information transferred from the PC is invalid.	Check whether the product specification or model name is correctly selected in atLightCurtain.
			The download for the setting information is incomplete.	Check the connection with PC and communication status.
$A \rightarrow 5$	1	Lamp 1 Warning	Lamp1 output is broken or short circuited.	Check whether the wiring of lamp 1 output is correct.
			Too much current flows into the Lamp 1 output.	Check whether the load that is connected to the lamp 1 output meets the rated range.
	2	Lamp 2 Warning	Lamp2 output is broken or short circuited.	Check whether the wiring of lamp 2 output is correct.
			Too much current flows into the Lamp 2 output.	Check whether the load that is connected to the lamp 2 output meets the rated range.
$A \rightarrow 6$	-	Sensitivity Reduction	The sensitivity reduction is occurred.	Check the alignment of the beams.
$A \rightarrow 7$	1	Mute 1 Warning	Sensor connected to the MUTE 1 input is in unstable state.	Check the status of muting sensor 1.
	2	Mute 2 Warning	Sensor connected to the MUTE 2 input is in unstable state.	Check the status of muting sensor 2.

※For more information on the error and warning code when using the atLightCurtain, see “atLightCurtain User Manual.”

12. Appendix

12.1 Glossary

Glossary	Description
Electro-sensitive protective equipment (ESPE)	Assembly of devices and/or components working together for protective tripping or presence sensing purposes and comprising as a minimum: 1) a sensing device; 2) controlling/monitoring devices; 3) output signal switching devices.
Sensing device	Part of the ESPE which uses electro-sensitive means to determine the event or state that the ESPE is intended to detect
Controlling/ Monitoring device	Part of the ESPE that: – Receives and processes information from the sensing device and provides signals to the OSSD, – Monitors the sensing device and the OSSD
Output signal switching device (OSSD)	When the sensing device is actuated during normal operation, the output circuit goes to OFF state.
Active onto-electronic protective device (AOPD)	A device whose sensing function is performed by onto-electronic emitting and receiving elements detecting the interruption of optical radiations generated, within the device, by an opaque materials present in the specified detection zone
Light curtain	An integrated assembly of multiple emitting elements and receiving elements forming a detection zone with a detection capability specified by the AOPD supplier
Detection capability	Dimension representing the diameter of the opaque test piece which will actuate the sensing device when placed in the detection zone
Beam center-line	Optical path joining the optical center of an emitting element and the optical center of the corresponding receiving element during normal operation
Effective Aperture Angle (EAA)	Maximum angle of deviation from the optical alignment of the emitting element(s) and the receiving element(s) within which the AOPD continues in normal operation
Geometrically Restricted Optical Design (GROD)	Geometrically restricted optical design 1) the effective aperture angle (EAA) of each emitting and each receiving element does not exceed the values given in the specification; 2) the axes of the beams are parallel; 3) side lobes are minimized; 4) the spacing between beam center-lines is uniform; 5) the value of detection capability is based on the complete obscuration of at least one beam for any and all positions of the test piece within the detection zone.
External device monitoring (EDM)	ESPE or AOPD monitors the state of external control devices
Muting	Temporary automatic suspension of a safety-related function(s), the OSSD outputs remain ON state regardless of the beams are blocked.
Blanking	Optional function that permits an object of a size greater than the detection capability of the ESPE or AOPD to be located within the detection zone without causing an OFF state of OSSD(s)
Stopping performance monitor (SPM)	Monitoring means to determine whether or nor the overall system stopping performance is within the preset limit(s)
Lockout condition	Condition, initiated by a fault, preventing normal operation of the ESPE or AOPD. All OSSD(s) are signaled to go to the OFF state.
Start interlock	Preventing an automatic machine start when the electrical supply to the ESPE or AOPD, or the supply is interrupted and restored.
Restart interlock	Preventing automatic restarting of a machine; • Actuation of the sensing device during a hazardous part of the machine operating cycle • A change in mode of operation of the machine or a change in the means of control of the machine

12.2 Manual revision history

Revision date	Descriptions
2020-09-08	First edition

Make Life Easy: Autonics